



## MM54C83/MM74C83 4-Bit Binary Full Adder

### General Description

The MM54C83/MM74C83 4-bit binary full adder performs the addition of two 4-bit binary numbers. A carry input ( $C_0$ ) is included and the sum ( $\Sigma$ ) outputs are provided for each bit and the resultant carry ( $C_4$ ) is obtained from the fourth bit. Since the carry-ripple-time is the limiting delay in the addition of a long word length, carry look-ahead circuitry has been included in the design to minimize this delay. Also, the logic levels of the input and output, including the carry, are in their true form. Thus the end-around carry is accomplished without the need for level inversion.

### Features

- Wide supply voltage range 3V to 15V
- Guaranteed noise margin 1V
- High noise immunity  $0.45 V_{CC}$  (typ.)
- Low power fan out of 2 driving 74L
- TTL compatibility
- Fast carry ripple 50 ns (typ.) @  $V_{CC} = 10V$  and  $C_L = 50 pF$  ( $C_0$  to  $C_4$ )
- Fast summing 125 ns (typ.) @  $V_{CC} = 10V$  and  $C_L = 50 pF$  ( $\Sigma_{IN}$  to  $\Sigma_{OUT}$ )

### Logic Diagram

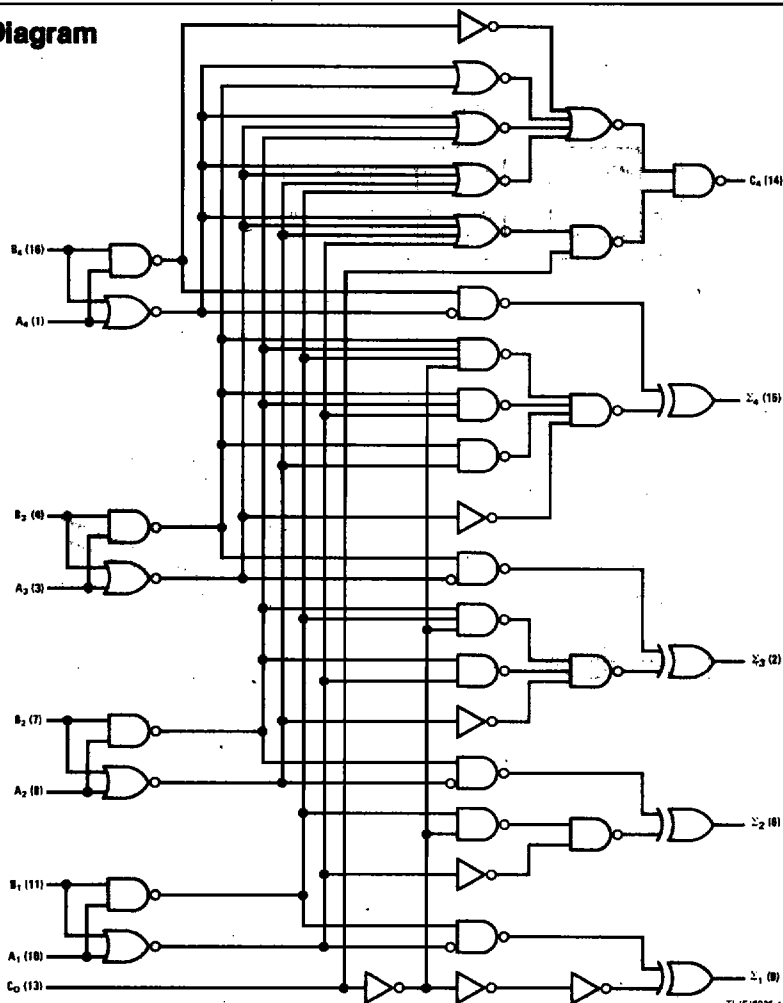

TLUF/6035-1

**Absolute Maximum Ratings** (Note 1)

Voltage at Any Pin	-0.3V to $V_{CC} + 0.3V$	Package Dissipation	500mW
Operating Temperature Range		Operating $V_{CC}$ Range	3V to 15V
MM54C83	-55°C to 125°C	Absolute Maximum $V_{CC}$	18V
MM74C83	-40°C to +85°C	Lead Temperature (Soldering, 10 seconds)	300°C
Storage Temperature Range	-65°C to +150°C		

**DC Electrical Characteristics** Min/max limits apply across temperature range unless otherwise noted.

Symbol	Parameter	Conditions	Min	Typ	Max	Units
<b>CMOS to CMOS</b>						
$V_{IN(1)}$	Logical "1" Input Voltage	$V_{CC} = 5.0V$ $V_{CC} = 10V$	3.5 8.0			V V
$V_{IN(0)}$	Logical "0" Input Voltage	$V_{CC} = 5.0V$ $V_{CC} = 10V$			1.5 2.0	V V
$V_{OUT(1)}$	Logical "1" Output Voltage	$V_{CC} = 5.0V, I_O = -10\mu A$ $V_{CC} = 10V, I_O = -10\mu A$	4.5 9.0			V V
$V_{OUT(0)}$	Logical "0" Output Voltage	$V_{CC} = 5.0V, I_O = +10\mu A$ $V_{CC} = 10V, I_O = +10\mu A$			0.5 1.0	V V
$I_{IN(1)}$	Logical "1" Input Current	$V_{CC} = 15V, V_{IN} = 15V$		0.005	1.0	$\mu A$
$I_{IN(0)}$	Logical "0" Input Current	$V_{CC} = 15V, V_{IN} = 0V$	-1.0	-0.005		$\mu A$
$I_{CC}$	Supply Current	$V_{CC} = 15V$		0.05	300	$\mu A$
<b>CMOS/LPTTL Interface</b>						
$V_{IN(1)}$	Logical "1" Input Voltage	54C, $V_{CC} = 4.5V$ 74C, $V_{CC} = 4.75V$	$V_{CC} - 1.5$ $V_{CC} - 1.5$			V V
$V_{IN(0)}$	Logical "0" Input Voltage	54C, $V_{CC} = 4.5V$ 74C, $V_{CC} = 4.75V$			0.8 0.8	V V
$V_{OUT(1)}$	Logical "1" Output Voltage	54C, $V_{CC} = 4.5V, I_O = -360\mu A$ 74C, $V_{CC} = 4.75V, I_O = -360\mu A$	2.4 2.4			V V
$V_{OUT(0)}$	Logical "0" Output Voltage	54C, $V_{CC} = 4.5V, I_O = 360\mu A$ 74C, $V_{CC} = 4.75V, I_O = 360\mu A$			0.4 0.4	V V
<b>Output Drive (See 54C/74C Family Characteristics Data Sheet) (short circuit current)</b>						
$I_{SOURCE}$	Output Source Current (P-Channel)	$V_{CC} = 5.0V, V_{OUT} = 0V$ $T_A = 25^\circ C$	-1.75	-3.3		mA
$I_{SOURCE}$	Output Source Current (P-Channel)	$V_{CC} = 10V, V_{OUT} = 0V$ $T_A = 25^\circ C$	-8.0	-15		mA
$I_{SINK}$	Output Sink Current (N-Channel)	$V_{CC} = 5.0V, V_{OUT} = V_{CC}$ $T_A = 25^\circ C$	1.75	3.6		mA
$I_{SINK}$	Output Sink Current (N-Channel)	$V_{CC} = 10V, V_{OUT} = V_{CC}$ $T_A = 25^\circ C$	8.0	16		mA

**Note 1:** "Absolute Maximum Ratings" are those values beyond which the safety of the device cannot be guaranteed. Except for "Operating Temperature Range" they are not meant to imply that the devices should be operated at these limits. The table of "Electrical Characteristics" provides conditions for actual device operation.

**Note 2:** Capacitance is guaranteed by periodic testing.

**Note 3:**  $C_{PD}$  determines the no load ac power consumption of any CMOS device. For complete explanation see 54C/74C Family Characteristics application note — AN-90.



# Typical Applications

## APPLICATION

Connect the MM54C83/MM74C83 in the following manner to implement a dual single bit full adder.

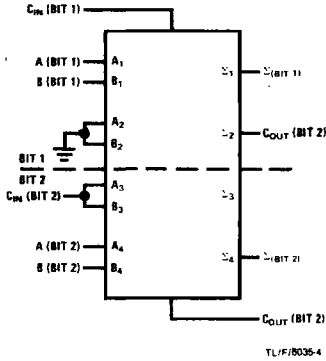

## CASCADING

Connect the MM54C83/MM74C83 in the following manner to implement full adders with more than 4 bits.

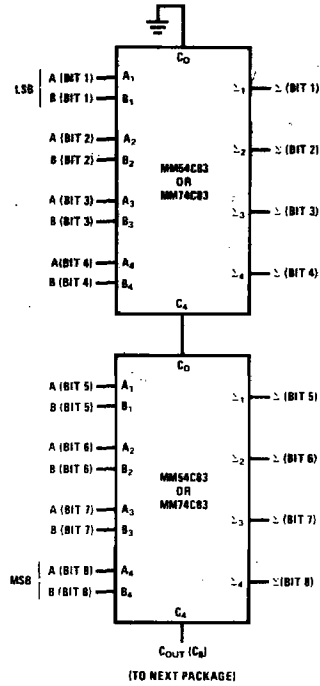

MM54C83/MM74C83

