



## | 3BT & 4BT SERIES

0°F to 350°F, Tiny Stat™ Precision Thermostats

### Introduction

Klixon® Tiny Stats combine an impressive list of superlatives in a reliable, hermetically sealed, snap-acting Klixon® design. They are the smallest envelope size ever developed — ideal for remote sensing applications in locations with severe space limitations. They are the lightest construction available — perfect for applications where weight is an important consideration. They have an extremely fast response in order to permit early warning of overheat conditions. The low mass internal components allow Tiny Stat precision thermostats to meet the most demanding shock and vibration standards of MIL-PRF-24236.



### Features

- Smallest snap-acting thermal switches ever made
- Extremely fast response
- Single pole, single throw (SPST)
- Normally open or closed
- Preset, non-adjustable calibration
- Hermetically sealed and back-filled with nitrogen
- Gold plated
- Various mounting configurations available
- Qualified to MIL-PRF-24236/13 (4BT) and MIL-PRF-24236/19 (3BT)
- Qualified to NASA S-311-641/06 (4BT) and NASA S-311-641/07 (3BT)



### PERFORMANCE CHARACTERISTICS

Gold plated contacts can be furnished to assure reliable circuit switching under low wattage conditions. (See second table below.) Gold plated contacts are not suitable for higher loads.

### Contact Ratings (Resistive) Based on standard differential

115 VAC / 30 VDC	30 mVAC*	30 mVDC*	Life Cycles
1.0 Amp	0.01 Amp	0.01 Amp	10,000

\* Specify gold contacts.

## Gold Contact Ratings (Resistive)

<b>30 VAC/DC</b>	500 mA and below
<b>115 VAC</b>	200 mA and below

## Characteristics

<b>Switch Action</b>	SPST (snap-action)
<b>Contact Resistance</b>	0.050 ohms maximum (0.100 ohms maximum for close on rise devices with setpoints greater than 175°F) per MIL-STD-202, Method 307
<b>Dielectric Strength</b>	500 vac, RMS, 60 Hz for 5 seconds, across open contacts, per MIL-STD-202, Method 301
<b>Vibration Resistance</b>	5–2000 Hz, 30 G, per MIL-STD-202, Method 204 <i>Vibration resistance specification does not apply to devices that open on temperature rise while at temperatures of 75°F or more below the opening temperature or to devices that close on temperature rise while at temperatures of 75°F or more above the closing temperature.</i>
<b>Shock Resistance</b>	100 G, 6 milliseconds per MIL-STD-202, Method 213
<b>Hermeticity</b>	1 x 10 <sup>-8</sup> atm cc/sec. maximum, per MIL-STD-202, Method 112, Condition C
<b>Salt Spray Resistance</b>	Per MIL-STD-202, Method 101, Condition B, 5% solution
<b>Weight</b>	Basic Unit: 0.2 to 0.9 grams
<b>Ambient Temperature Range</b>	-80°F to 350°F (-62.2°C to 176.7°C)

## Operating Temperature

Standard temp settings (dash 1 to 71) are shown in the temperature table below. Sensata can make thermostats to any custom set point temperature within the specified operating temperature range. Contact factory for assistance with custom set point temperatures.

Dash	Operating Temperature		Differential		Tolerance	
#	°F	°C	°F	°C	±°F	±°C
1	0	-17.8	30	16.7	8	4.4
2	5	-15.0	30	16.7	8	4.4
3	10	-12.2	30	16.7	8	4.4
4	15	-9.4	30	16.7	8	4.4
5	20	-6.7	30	16.7	8	4.4
6	25	-3.9	30	16.7	8	4.4
7	30	-1.1	30	16.7	8	4.4
8	35	1.7	30	16.7	8	4.4
Dash	Operating Temperature		Differential		Tolerance	
#	°F	°C	°F	°C	±°F	±°C
9	40	4.4	30	16.7	8	4.4
10	45	7.2	30	16.7	8	4.4
11	50	10.0	30	16.7	8	4.4
12	55	12.8	30	16.7	8	4.4
13	60	15.6	30	16.7	8	4.4
14	65	18.3	30	16.7	8	4.4
15	70	21.1	30	16.7	8	4.4
16	75	23.9	30	16.7	8	4.4

## Operating Temperature (continued)









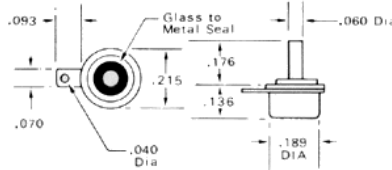

Dash	Operating Temperature		Differential		Tolerance	
#	°F	°C	°F	°C	±°F	±°C
17	80	26.7	30	16.7	8	4.4
18	85	29.4	30	16.7	8	4.4
19	90	32.2	30	16.7	8	4.4
20	95	35.0	30	16.7	8	4.4
21	100	37.8	30	16.7	8	4.4
22	105	40.6	30	16.7	8	4.4
23	110	43.3	30	16.7	8	4.4
24	115	46.1	30	16.7	8	4.4
Dash	Operating Temperature		Differential		Tolerance	
#	°F	°C	°F	°C	±°F	±°C
25	120	48.9	30	16.7	8	4.4
26	125	51.7	30	16.7	8	4.4
27	130	54.4	30	16.7	8	4.4
28	135	57.2	30	16.7	8	4.4
29	140	60.0	30	16.7	8	4.4
30	145	62.8	30	16.7	8	4.4
31	150	65.6	30	16.7	8	4.4
32	155	68.3	30	16.7	8	4.4
Dash	Operating Temperature		Differential		Tolerance	
#	°F	°C	°F	°C	±°F	±°C
33	160	71.1	30	16.7	8	4.4
34	165	73.9	30	16.7	8	4.4
35	170	76.7	30	16.7	8	4.4
36	175	79.4	30	16.7	8	4.4
37	180	82.2	30	16.7	8	4.4
38	185	85.0	30	16.7	8	4.4
39	190	87.8	30	16.7	8	4.4
40	195	90.6	30	16.7	8	4.4
Dash	Operating Temperature		Differential		Tolerance	
#	°F	°C	°F	°C	±°F	±°C
41	200	93.3	30	16.7	8	4.4
42	205	96.1	30	16.7	8	4.4
43	210	98.9	30	16.7	8	4.4
44	215	101.7	30	16.7	8	4.4
45	220	104.4	30	16.7	8	4.4
46	225	107.2	30	16.7	8	4.4
47	230	110.0	30	16.7	8	4.4
48	235	112.8	30	16.7	8	4.4

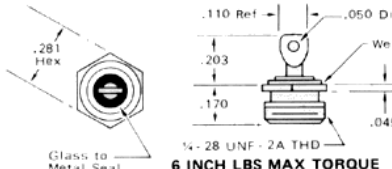
## Operating Temperature (continued)

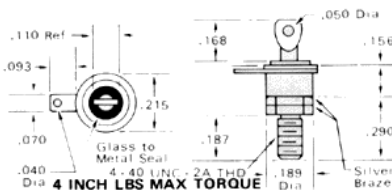
Dash	Operating Temperature		Differential		Tolerance	
#	°F	°C	°F	°C	±°F	±°C
49	240	115.6	30	16.7	8	4.4
50	245	118.3	30	16.7	8	4.4
51	250	121.1	30	16.7	8	4.4
52	255	123.9	30	16.7	8	4.4
53	260	126.7	30	16.7	8	4.4
54	265	129.4	30	16.7	8	4.4
55	270	132.2	30	16.7	8	4.4
56	275	135.0	30	16.7	8	4.4
Dash	Operating Temperature		Differential		Tolerance	
#	°F	°C	°F	°C	±°F	±°C
57	280	137.8	30	16.7	8	4.4
58	285	140.6	30	16.7	8	4.4
59	290	143.3	30	16.7	8	4.4
60	295	146.1	30	16.7	8	4.4
61	300	148.9	30	16.7	8	4.4
62	305	151.7	30	16.7	8	4.4
63	310	154.4	30	16.7	8	4.4
64	315	157.2	30	16.7	8	4.4
Dash	Operating Temperature		Differential		Tolerance	
#	°F	°C	°F	°C	±°F	±°C
65	320	160.0	30	16.7	8	4.4
66	325	162.8	30	16.7	8	4.4
67	330	165.6	30	16.7	8	4.4
68	335	168.3	30	16.7	8	4.4
69	340	171.1	30	16.7	8	4.4
70	345	173.9	30	16.7	8	4.4
71	350	176.7	30	16.7	8	4.4

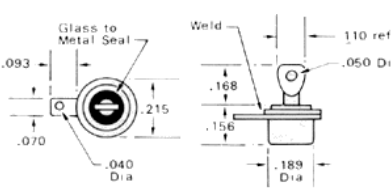
<b>Pin-Type</b>	For quick assembly to printed circuit boards (3BT-2 and 3BT-15)
<b>Threaded Plug</b>	For surface temperature sensing (3BT-3)
<b>Insulated Version</b>	For applications where grounded case construction is not suitable (3BT-6)
<b>Low Profile</b>	For applications where an extremely low profile is critical (4BT-2)
<b>Other</b>	Other styles are available

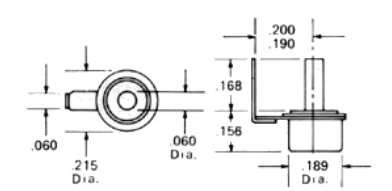
Our most common configurations are shown below, but other styles are available:

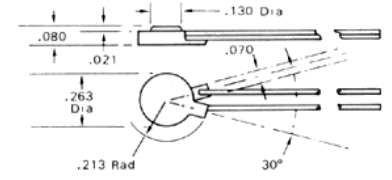
<p><b>3BT-2</b></p>  <p>Grounded case construction Approx. wt. 0.4 grams Conforms to MIL-S-24236/19 configuration 1</p>	 <p>Dimensions: .093, .070, .215, .040 Dia, .176, .136, .060 Dia, .189 Dia</p> <p>Labels: Glass to Metal Seal</p>
<p><b>3BT-3</b></p>  <p>Grounded case construction Approx. wt. 0.9 grams Conforms to MIL-S-24236/19 configuration 2</p>	 <p>Dimensions: .281 Hex, .110 Ref, .203, .170, .050 Dia, .045</p> <p>Labels: Glass to Metal Seal, Weld, 1/4 - 28 UNF - 2A THD</p> <p><b>6 INCH LBS MAX TORQUE</b></p>
<p><b>3BT-6</b></p>  <p>Case insulated Approx. wt. 0.9 grams Conforms to MIL-S-24236/19 configuration 3</p>	 <p>Dimensions: .110 Ref, .093, .070, .215, .040 Dia, .168, .187, .189 Dia, .156, .290</p> <p>Labels: Glass to Metal Seal, 1/4 - 40 UNF - 2A THD, Silver Braze</p> <p><b>4 INCH LBS MAX TORQUE</b></p>
<p><b>3BT-8</b></p>  <p>Grounded case construction Approx. wt. 0.4 grams Conforms to MIL-S-24236/19 configuration 4</p>	 <p>Dimensions: .093, .070, .215, .040 Dia, .168, .156, .110 ref, .050 Dia, .189 Dia</p> <p>Labels: Glass to Metal Seal, Weld</p>
<p><b>3BT-15</b></p>  <p>Printed circuit board mount Approx. wt. 0.4 grams Conforms to MIL-S-24236/19 configuration 5</p> <p>Actual size</p>	 <p>Dimensions: .060, .215 Dia., .060 Dia., .168, .156, .200, .190, .189 Dia.</p>
<p><b>4BT-2</b></p>  <p>Grounded case construction Approx. wt. 0.2 grams Conforms to MIL-S-24236/13</p>	 <p>Dimensions: .080, .021, .130 Dia, .070, .263 Dia, .213 Rad, 30°</p>

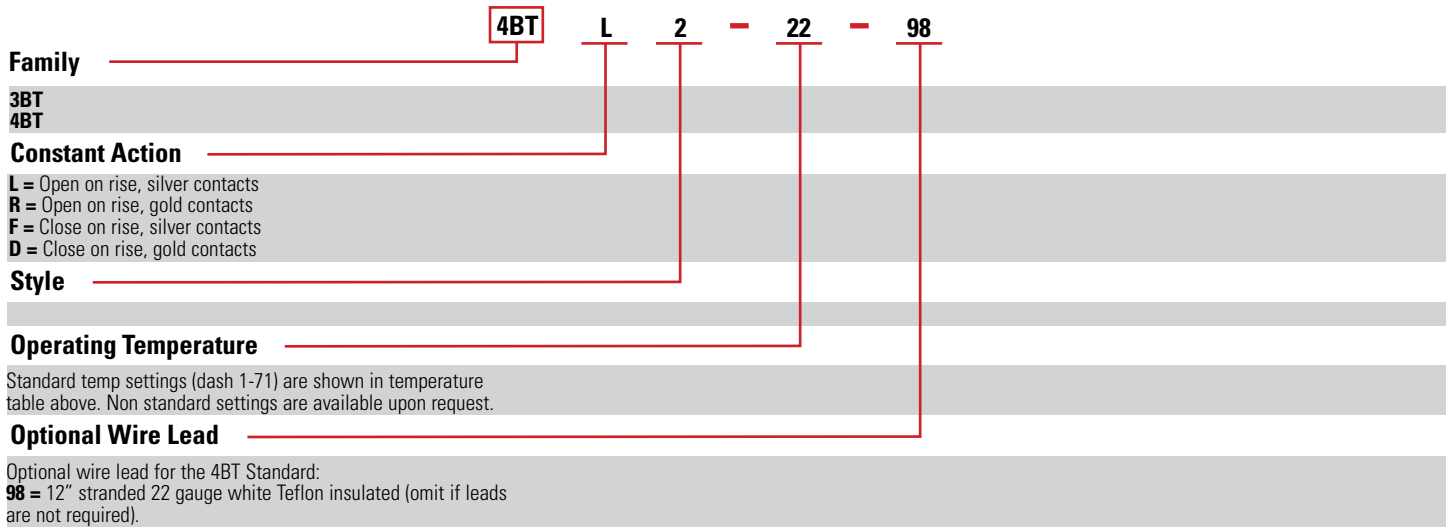



## WARNINGS



### RISK OF MATERIAL DAMAGE AND HOT ENCLOSURE

- The product's side panels may be hot, allow the product to cool before touching
- Follow proper mounting instructions including torque values
- Do not allow liquids or foreign objects to enter this product

**Failure to follow these instructions can result in serious injury, or equipment damage.**



### HAZARD OF ELECTRIC SHOCK, EXPLOSION OR ARCH FLASH

- Disconnect all power before installing or working with this equipment
- Verify all connections and replace all covers before turning on power

**Failure to follow these instructions will result in death or serious injury.**

Revised 2/12/17

Sensata Technologies, Inc. ("Sensata") data sheets are solely intended to assist designers ("Buyers") who are developing systems that incorporate Sensata products (also referred to herein as "components"). Buyer understands and agrees that Buyer remains responsible for using its independent analysis, evaluation and judgment in designing Buyer's systems and products. Sensata data sheets have been created using standard laboratory conditions and engineering practices. Sensata has not conducted any testing other than that specifically described in the published documentation for a particular data sheet. Sensata may make corrections, enhancements, improvements and other changes to its data sheets or components without notice.

Buyers are authorized to use Sensata data sheets with the Sensata component(s) identified in each particular data sheet. HOWEVER, NO OTHER LICENSE, EXPRESS OR IMPLIED, BY ESTOPPEL OR OTHERWISE TO ANY OTHER SENSATA INTELLECTUAL PROPERTY RIGHT, AND NO LICENSE TO ANY THIRD PARTY TECHNOLOGY OR INTELLECTUAL PROPERTY RIGHT, IS GRANTED HEREIN. SENSATA DATA SHEETS ARE PROVIDED "AS IS". SENSATA MAKES NO WARRANTIES OR REPRESENTATIONS WITH REGARD TO THE DATA SHEETS OR USE OF THE DATA SHEETS, EXPRESS, IMPLIED OR STATUTORY, INCLUDING ACCURACY OR COMPLETENESS. SENSATA DISCLAIMS ANY WARRANTY OF TITLE AND ANY IMPLIED WARRANTIES OF MERCHANTABILITY, FITNESS FOR A PARTICULAR PURPOSE, QUIET ENJOYMENT, QUIET POSSESSION, AND NON-INFRINGEMENT OF ANY THIRD PARTY INTELLECTUAL PROPERTY RIGHTS WITH REGARD TO SENSATA DATA SHEETS OR USE THEREOF.

All products are sold subject to Sensata's terms and conditions of sale supplied at [www.sensata.com](http://www.sensata.com) SENSATA ASSUMES NO LIABILITY FOR APPLICATIONS ASSISTANCE OR THE DESIGN OF BUYERS' PRODUCTS. BUYER ACKNOWLEDGES AND AGREES THAT IT IS SOLELY RESPONSIBLE FOR COMPLIANCE WITH ALL LEGAL, REGULATORY AND SAFETY-RELATED REQUIREMENTS CONCERNING ITS PRODUCTS, AND ANY USE OF SENSATA COMPONENTS IN ITS APPLICATIONS, NOTWITHSTANDING ANY APPLICATIONS-RELATED INFORMATION OR SUPPORT THAT MAY BE PROVIDED BY SENSATA.

Mailing Address: Sensata Technologies, Inc., 529 Pleasant Street, Attleboro, MA 02703, USA.

## CONTACT US

### Americas

+1 (888) 438 2214  
[sensors@sensata.com](mailto:sensors@sensata.com)

### Europe, Middle East & Africa

+31 (74) 357 8156  
[temperature-info.eu@sensata.com](mailto:temperature-info.eu@sensata.com)

### Asia Pacific

[sales.isasia@list.sensata.com](mailto:sales.isasia@list.sensata.com)  
 China +86 (21) 2306 1500  
 Japan +81 (45) 277 7117  
 Korea +82 (31) 601 2004  
 India +91 (80) 67920890  
 Rest of Asia +886 (2) 27602006  
 ext 2808