

**OD-X8HXXXXX**

**Extremely Low Power Consumption, Fast Warm-up, SC-cut, Precision, Very Low Phase Noise OCXO in 20x20 mm Through Hole Package**

**Product Data Sheet**

**Features**

- SC-cut crystal
- High Stability (up to  $\pm 5 \times 10^{-9}$ )
- Low Aging ( $5 \times 10^{-10}$ /day,  $5 \times 10^{-8}$ /year)
- Very Low Phase Noise (-160 dBc/Hz, TYP, floor)
- Sine Wave or HCMOS/TTL output
- 4.8 MHz to 160 MHz Frequencies Available

**Applications**

- Telecommunication Systems
- Data Communications
- GPS
- Instrumentation

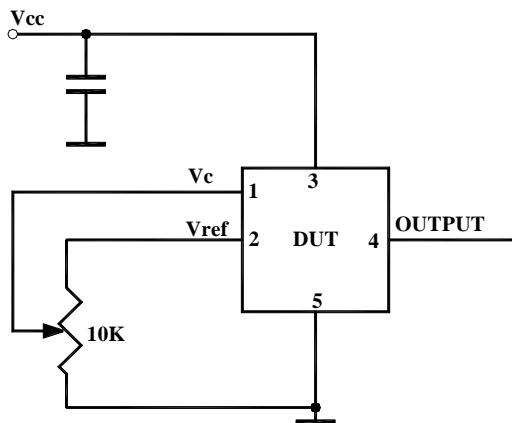
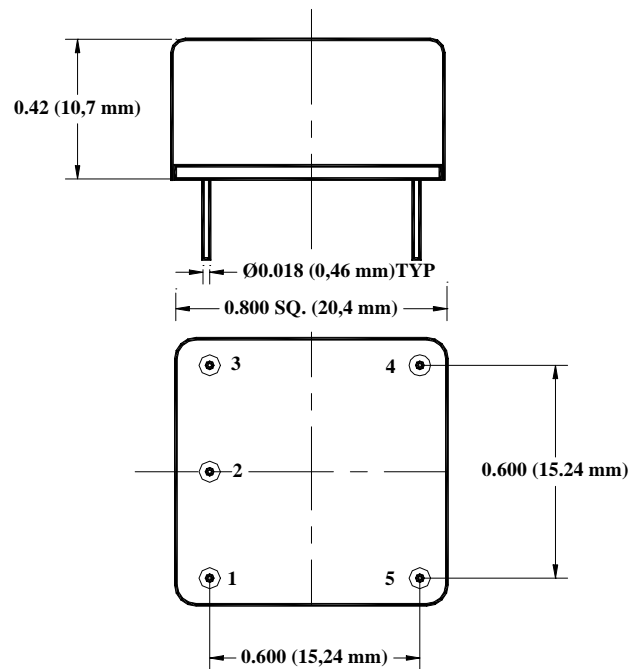

## OD-X8HXXXX Series

Rev. B

Parameter	Symb	Condition	Min	Typ	Max	Unit	Note
<i>Absolute Maximum Ratings</i>							
<b>Input Break Down Voltage</b>	Vcc		-0.5		13.0	V	
<b>Storage temper.</b>	Ts		-40		85	°C	
<b>Control Voltage</b>	Vc		-1		9	V	

### Electrical

<b>Frequency</b>	F		4.8	10.000	160	MHz	1*	All parameters for 10 MHz
<b>Frequency stability</b>	$\Delta F/F$	vs. Temp.		$\pm 10$		ppb	See chart below	
		vs. Supply		1	2	ppb/V		
<b>Aging</b>		per day per year		5E-10 1E-7			after 30 days 5E-8 available2*	
<b>Allan Variance</b>		.1s to 10s		1E-11				
<b>SSB Phase Noise</b>		1 Hz		-90		dBc/Hz	3*	
		10 Hz		-120				
		100 Hz		-150				
		1 KHz		-153				
		10 KHz		-160				
<b>Retrace</b>		After 30 minutes			$\pm 10$	ppb		
<b>G-sensitivity</b>		worst direction			$\pm 1.0$	ppb/G		
<b>Input Voltage</b>	Vcc		4.75 3.15 11.4	5.0 3.3 12.0	5.25 3.45 12.6	V	See chart below to specify	
<b>Power consumption</b>	P	steady state, 25°C steady state, -30°C start-up @ -30°C		0.8 1.5 2.5	1.2 3.2	W	Standard Operating Temperature, for Op Temp. 85 °C ad 20%	
<b>Spectral Purity</b>		Subharmonics Spurious Harmonics/Sine		-50 -35	-45 -30	dBc	At Higher Frequencies	
<b>Load</b>	10KOhm//15pF (HCMOS/TTL), 50 Ohm (Sinewave)							
<b>Warm-up time</b>	$\tau$	to 0.1ppm accuracy		3	5	minutes	3 min. at 12V	
<b>Output Waveform</b>	3.3V HCMOS/TTL compatible or Sinewave (+7±3) dBm						-25dBm Harmonics at sine	
<b>Control voltage</b>	Vc		0		4.0	V		
<b>Pull range</b>		from nominal F	$\pm 0.5$	$\pm 1$		ppm		
<b>Deviation slope</b>		Monotonic, posit		0.4		ppm/V		
<b>Setability</b>	Vc0	@25°C, Fnom.	1.0	2.0	3.0	V		

### Environmental and Mechanical

<b>Operating temp. range</b>	-30°C to 70°C Standard, Other options – see chart below
<b>Mechanical Shock</b>	Per MIL-STD-202, 30G, 11ms
<b>Vibration</b>	Per MIL-STD-202, 5G to 2000 Hz
<b>Soldering Conditions</b>	260°C for 10s Max leads only

### Electrical Connections

<b>Pin Out</b>	Pin #1-Vc ; Pin#2 – Vref; Pin #3 – Vcc; Pin #4- Output ; Pin #5- GND;
----------------	---

Notes: 1\* Higher frequencies can be achieved either by using higher frequency crystals or by low noise analog harmonic multiplication. Both methods have advantages and drawbacks. If lowest possible phase noise on the noise floor is most important – high frequency crystal will be used. If phase noise close to the carrier and aging are more important – multiplication will be used. Please consult factory for your specific requirement.

2\* Aging rate is usually proportional to the operating frequency, unless higher frequency is achieved by multiplication. Keep it in mind while specifying aging.

3\* Phase noise deteriorates with frequencies going higher. If analog multiplication is used to achieve higher frequency the phase noise roughly follows the formula of additional 20LogN, where N is a multiplication factor across entire frequency offset range. If higher frequency is achieved by using higher frequency crystal phase noise close to the carrier deteriorates due to the lower Q of the crystal and is usually worse, compared to multiplied solution. On the noise floor, however it remains more or less the same. This design usually starts utilizing multiplication techniques in the range of 25 MHz to 35 MHz.

## OD-X8HXXXXX Series

Rev. B

### Creating a Part Number

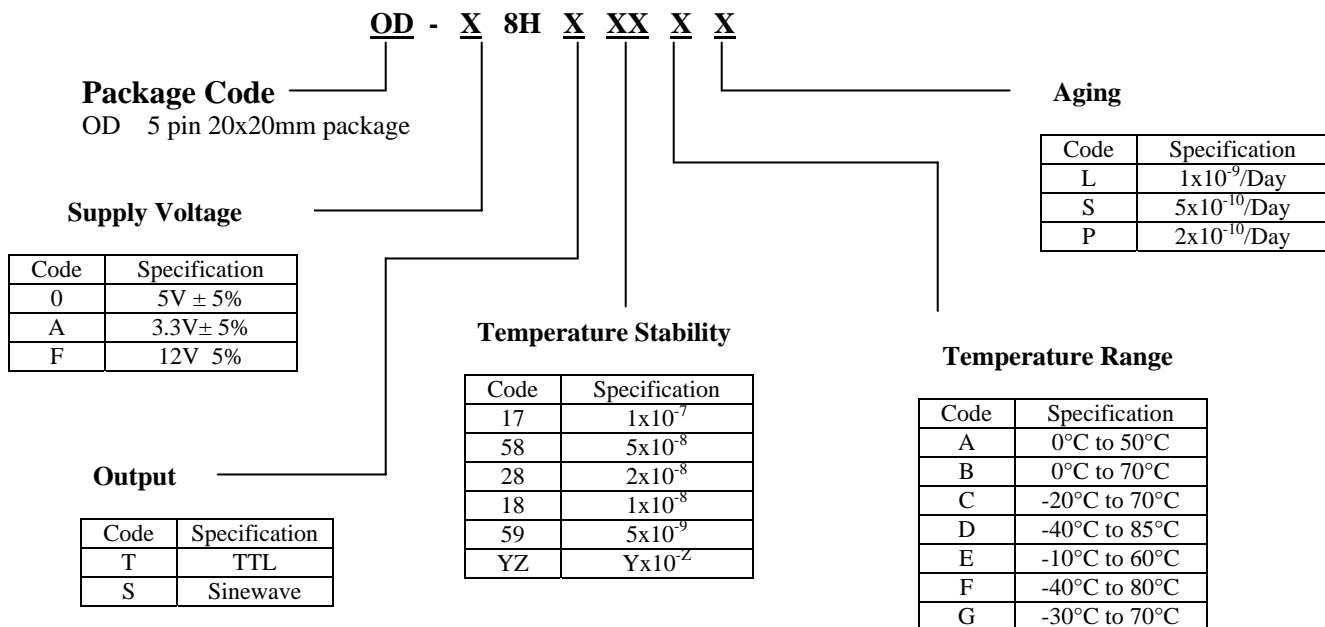

Not all combinations are available. Consult Factory.

