

Power Transformers/MIL-T-27

400 Hz Miniature

ELECTRICAL SPECIFICATIONS

Primary voltage [1-2] = 115V $\pm 10\%$
400 Hz $\pm 5\%$

Secondary Voltage $\pm 3\%$ with [1-2] = 115V 400 Hz and delivering rated load. [Range 5 to 300V]

Dielectric strength 2.8 x max working voltage

See table for balance of specifications.

PHYSICAL SPECIFICATIONS

Size—sizes for standard VA ratings are given in Table.

Construction: Grade 5, Class S per MIL-T-27.

VA Rating	Package Size	Height Max	Reg. Max %	Δt Max $^{\circ}\text{C}$	Weight Max oz
1.5	1.09 sq.	0.47	23	17	.85
1.5S	1.09 sq.	0.59	18	17	1.10
3.0	1.09 sq.	0.59	18	20	1.10
3.0S	1.09 sq.	0.78	12	20	1.65
6.0	1.09 sq.	0.78	12	25	1.65
6.0S	1.09 sq.	1.03	10	25	2.20
9.0	1.09 sq.	1.03	10	30	2.20
9.0S	1.40 sq.	0.97	8	32	3.40
16	1.40 sq.	0.97	8	32	3.40
25	1.40 sq.	1.20	7	45	4.40

HOW TO ORDER

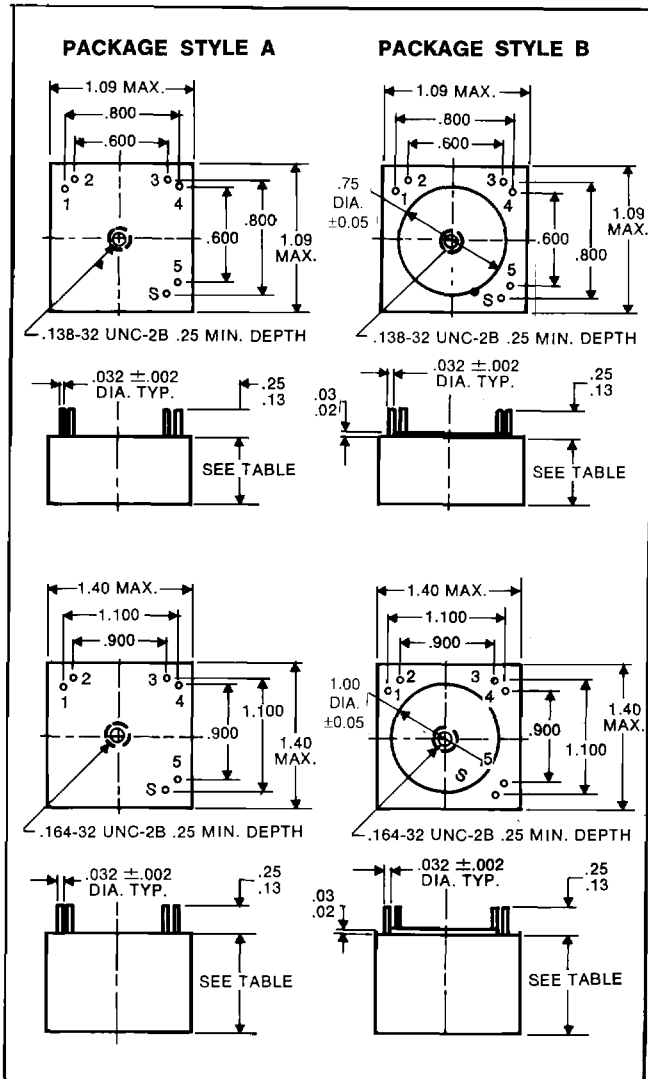
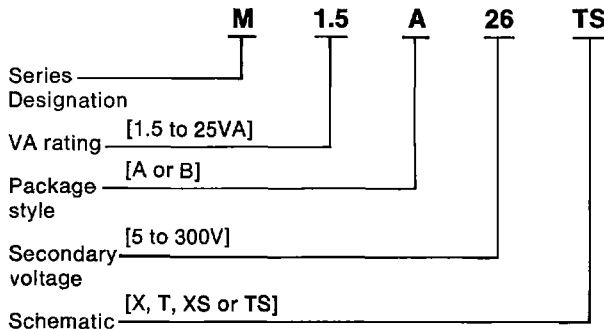

SCHMATIC "X"

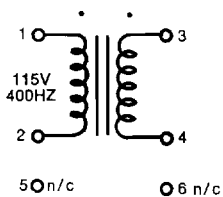

SCHMATIC "T" (CENTER TAP)

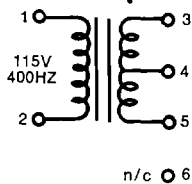

SCHMATIC "XS"

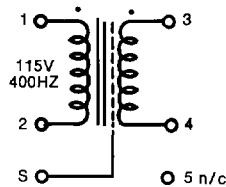

SCHMATIC "TS" (CENTER TAP)

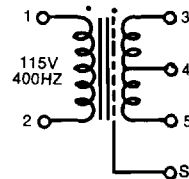

385 HIGHWAY 33, ENGLISHTOWN, NJ 07726
908/446-3110 FAX 908/446-5362