

National Semiconductor is now part of
Texas Instruments.

Search <http://www.ti.com/> for the latest technical
information and details on our current products and services.

Class G Headphone Amplifier with I²C Volume Control

General Description

The LM48824 is a Class G, ground-referenced stereo headphone amplifier designed for portable devices. The LM48824 features National's ground-referenced architecture, which eliminates the large DC blocking capacitors required by traditional headphone amplifiers, saving board space and minimizing system cost.

The LM48824 takes advantage of National's patent-pending Class G architecture offering power savings compared to a traditional Class AB headphone amplifier. Additionally, output noise is improved by common-mode sensing that corrects for any differences between the amplifier ground and the potential at the headphone return terminal, minimizing noise created by any ground mismatches.

A high output impedance mode allows the LM48824's outputs to be driven by an external source without degrading the signal. Other features include flexible power supply requirements, differential inputs for improved noise rejection, a low power (2.5µA) shutdown mode, and a 32-step I²C volume control with mute function.

The LM48824's superior click and pop suppression eliminates audible transients on power-up/down and during shutdown. The LM48824 is available in an ultra-small 16-bump, 0.4mm pitch micro SMD package (1.69mm x 1.69mm)

Key Specifications

■ Quiescent Power Supply Current at 3.6V	0.9mA (typ)
■ Output Power/channel at V _{DD} = 3.6V R _L = 16Ω, THD+N ≤ 1%	37mW (typ)
■ Output Power/channel at V _{DD} = 3.6V R _L = 32Ω, THD+N ≤ 1%	29mW (typ)
■ PSRR at 217Hz	100dB (typ)
■ Shutdown current	2.5µA (typ)

Features

- Class G Power Savings
- Ground Referenced Headphone Outputs – Eliminates Output Coupling Capacitors
- Common-Mode Sense
- I²C Volume and Mode Control
- High Output Impedance in Shutdown
- Differential Inputs
- Advanced Click-and-Pop Suppression
- Low Supply Current
- Low THD mode option

Applications

- Mobile Phones, PDAs, MP3 Players
- Portable Electronic Devices, Notebook PCs

Simplified Block Diagram

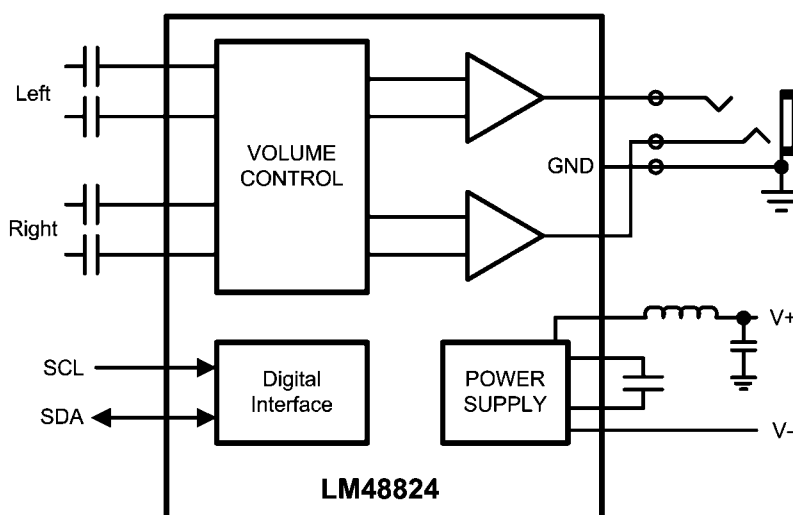

30089221

Typical Application

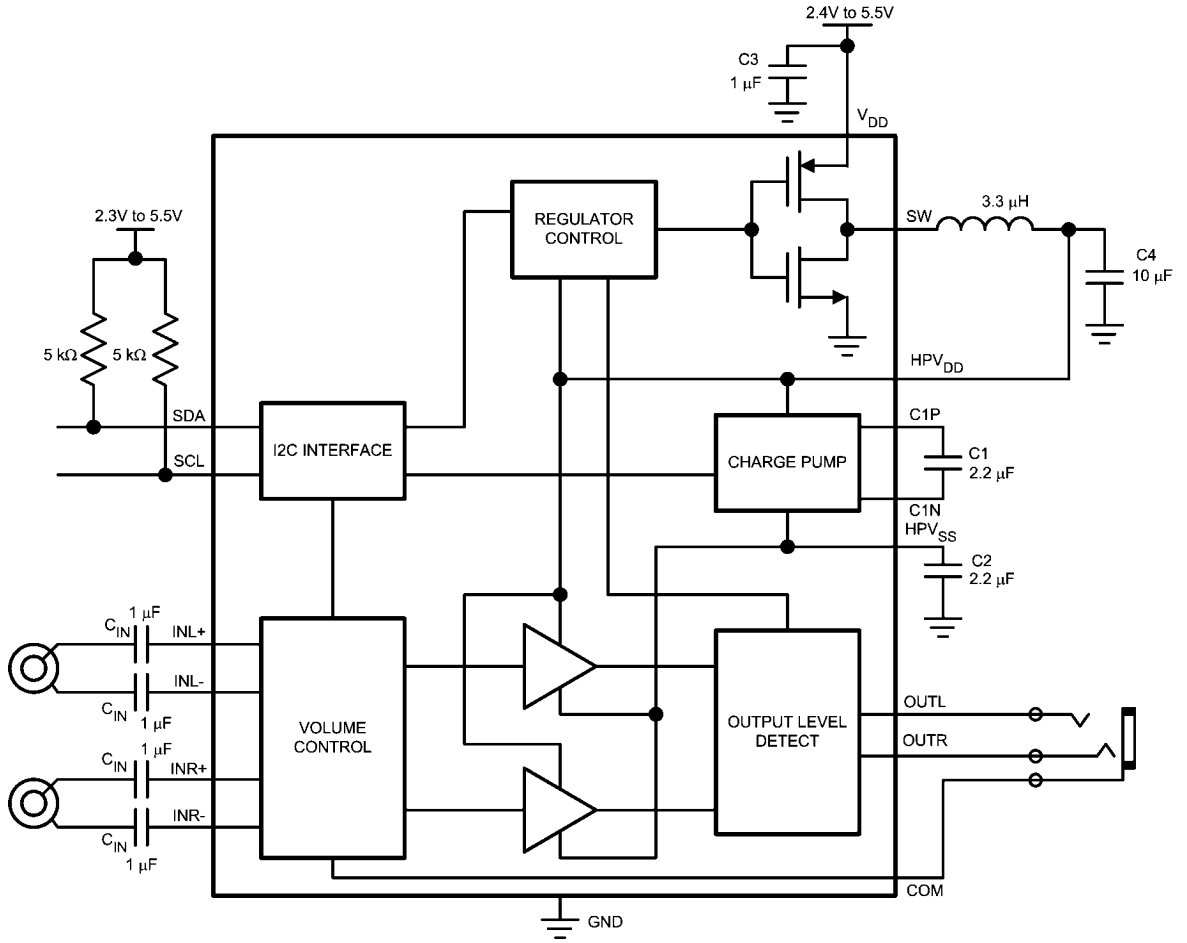

30089270

FIGURE 1. Typical Audio Amplifier Application Circuit

Connection Diagrams

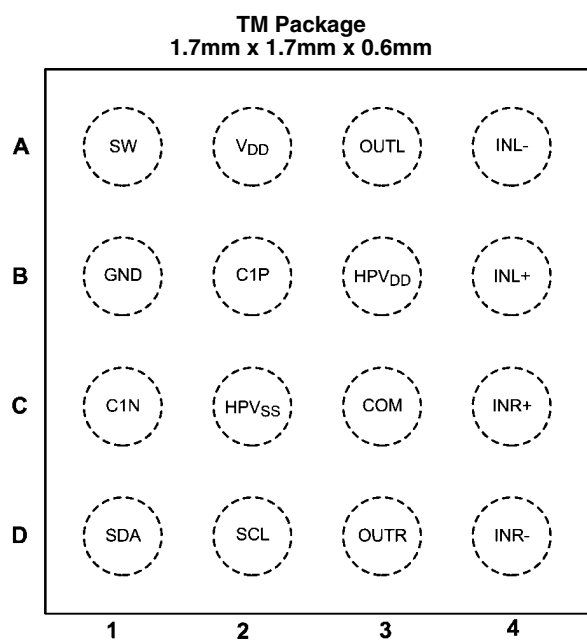

30089220

Top View
Order Number LM48824TM
See NS Package Number TMD16DDA

16-Bump micro SMD Marking

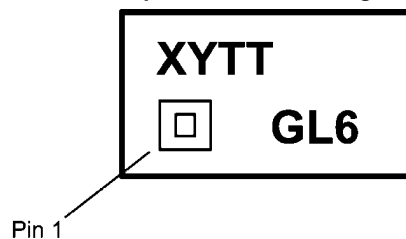

30089217

Top View
XY = Date code
TT = Die traceability
G = Boomer Family
L6 = LM48824TM

Ordering Information

Order Number	Package	Package DWG #	Transport Media	MSL Level	Green Status
LM48824TM	16 Bump micro SMD	TMD16DDA	250 units on tape and reel	1	NOPB
LM48824TMX	16 Bump micro SMD	TMD16DDA	3000 units on tape and reel	1	NOPB

Bump Descriptions

Bump	Name	Pin Descriptions
A1	SW	Regulator Switching Node
A2	V _{DD}	Power Supply
A3	OUTL	Left Channel Output
A4	INL-	Left Channel Inverting Input
B1	GND	Ground
B2	C1P	Charge Pump Flying Capacitor Positive Terminal
B3	HPV _{DD}	Amplifier Power Supply/Regulator Output
B4	INL+	Left Channel Non-Inverting Input
C1	C1N	Charge Pump Flying Capacitor Negative Terminal
C2	HPV _{SS}	Charge Pump Output
C3	COM	Common-mode Sense Input. Connect to headphone jack return
C4	INR+	Right Channel Non-Inverting Input
D1	SDA	I2C Serial Data Input
D2	SCL	I2C Serial Clock Input
D3	OUTR	Right Channel Output
D4	INR-	Right Channel Inverting Input

Absolute Maximum Ratings (Note 1, Note 2)

If Military/Aerospace specified devices are required, please contact the National Semiconductor Sales Office/Distributors for availability and specifications.

Supply Voltage (Note 1)	6V
Storage Temperature	-65°C to +150°C
Input Voltage	-0.3V to $V_{DD} + 0.3V$
Power Dissipation (Note 3)	Internally Limited
ESD Rating (Note 4)	2000V
ESD Rating (Note 5)	200V
ESD Rating (Note 6)	500V
Junction Temperature	150°C

Soldering Information Vapor Phase (60 sec.)	215°C
Infrared (15 sec.)	220°C
Thermal Resistance θ_{JA} (TMA16DDA)	60°C/W
Soldering Information See AN-1112 "Micro SMD Wafer Level Chip Scale package"	

Operating Ratings

Temperature Range	$T_{MIN} \leq T_A \leq T_{MAX}$	$-40^\circ\text{C} \leq T_A \leq +85^\circ\text{C}$
Supply Voltage (V_{DD})		$2.4V \leq V_{DD} \leq 5.5V$

Electrical Characteristics $V_{DD} = 3.6V$ (Note 1, Note 2)

The following specifications apply for $A_V = 0\text{dB}$, $R_L = 32\Omega$, $f = 1\text{kHz}$, unless otherwise specified. Limits apply to $T_A = 25^\circ\text{C}$.

Symbol	Parameter	Conditions	LM48824		Units (Limits)
			Typical (Note 7)	Limit (Note 8)	
I_{DD}	Quiescent Power Supply Current	$V_{IN} = 0V$, both channels active $R_L = \infty$	0.9	1.3	mA (max)
		$R_L = \infty$, Low THD mode	1.55		mA
$I_{DD(OP)}$	Operating Power Supply Current	$P_O = 100\mu\text{W}$, two channels in phase, 3dB Crest Factor, $R_L = 32\Omega + 15\Omega$	1.8	2.5	mA (max)
		$P_O = 100\mu\text{W}$, two channels in phase, 3dB Crest Factor, $R_L = 32\Omega + 15\Omega$, Low THD mode	2.2		mA
		$P_O = 500\mu\text{W}$, two channels in phase, 3dB Crest Factor $R_L = 32\Omega + 15\Omega$	3.1	3.8	mA (max)
		$P_O = 500\mu\text{W}$, two channels in phase, 3dB Crest Factor $R_L = 32\Omega + 15\Omega$, Low THD mode	3.4		mA
		$P_O = 1\text{mW}$, two channels in phase, 3dB Crest Factor, $R_L = 32\Omega + 15\Omega$	4.1	4.9	mA (max)
		$P_O = 1\text{mW}$, two channels in phase, 3dB Crest Factor, $R_L = 32\Omega + 15\Omega$, Low THD mode	4.4		mA
I_{SD}	Shutdown Current	Shutdown Enabled $V_{SCL} = V_{SDA} = 1.8V$	2.5	3.9	μA (max)
V_{OS}	Output Offset Voltage	$V_{IN} = 0V$	0.15	0.65	mV (max)
T_{WU}	Wake Up Time	From Shutdown	2		ms
A_V	Gain	Minimum Gain Setting	-59	-58 -60	dB (max) dB (min)
		Maximum Gain Setting	4	4.5 3.5	dB (max) dB (min)
$A_{V(MUTE)}$	Mute Attenuation		-110		dB
R_{IN}	Input Resistance	$A_V = 4\text{dB}$	24	20	$\text{k}\Omega$ (min)
		$A_V = -59\text{dB}$	64	80	$\text{k}\Omega$ (max)

Symbol	Parameter	Conditions	LM48824		Units (Limits)
			Typical (Note 7)	Limit (Note 8)	
P _O	Output Power	f = 1kHz, THD+N = 1% Two channels in phase R _L = 16Ω	37	30	mW (min)
		f = 1kHz, THD+N = 1% Two channels in phase R _L = 32Ω,	29	23	mW (min)
V _O	Output Swing	THD+N = 1%, Two Channels in Phase			
		R _L = 16Ω	0.77	0.7	V _{RMS} (min)
		R _L = 32Ω	0.96	0.86	V _{RMS} (min)
		R _L = 32Ω + 15Ω	1.05		V _{RMS}
		R _L = 10kΩ	1.3	1.1	V _{RMS} (min)
THD+N	Total Harmonic Distortion + Noise	f = 1kHz, Single Channel			
		V _O = 600mV _{RMS} , R _L = 16Ω	0.05		%
		V _O = 600mV _{RMS} , R _L = 16Ω, Low THD Mode	0.03		%
		V _O = 800mV _{RMS} , R _L = 32Ω,	0.035		%
		V _O = 800mV _{RMS} , R _L = 32Ω, Low THD Mode	0.02		%
		V _O = 900mV _{RMS} , R _L = 32Ω+ 15Ω	0.027	0.04	%(max)
		V _O = 900mV _{RMS} , R _L = 32Ω+ 15Ω, Low THD Mode	0.015		%
PSRR	Power Supply Rejection Ratio	V _{RIPPLE} = 200mV _{P-P} , Inputs AC GND C _{IN} = 1μF, input referred,			
		f _{RIPPLE} = 217Hz	100	94	dB (min)
		f _{RIPPLE} = 1kHz	100		dB
CMRR	Common Mode Rejection Ratio	V _{RIPPLE} = 1V _{P-P} , f _{RIPPLE} = 217Hz	60		dB
X _{TALK}	Crosstalk	R _L ≥ 16Ω, P _O = 5mW, f = 1kHz	80	70	dB (min)
		R _L ≥ 10kΩ, V _{OUT} = 1V _{RMS} , f = 1kHz	110	95	dB (min)
SNR	Signal-to-Noise Ratio	V _{OUT} = 1V _{RMS} , f = 1kHz	102	98	dB (min)
		V _{OUT} = 1V _{RMS} , f = 1kHz, Low THD Mode	105		dB
ε _{OS}	Output Noise	A _V = 4dB, A-Weighted Filter	8	12	μV(max)
		A _V = 4dB, A-weighted Filter, Low THD Mode	7		μV
R _{OUT}	Output Impedance	Charge pump-only mode enabled			
		f < 40kHz	43	30	kΩ (min)
		f = 6MHz		500	Ω (min)
		f = 36MHz		75	Ω (min)
C _L	Maximum Capacitive Load	No Sustained Oscillations			
		with 5Ω series resistance	100		nF
		with no series resistance	100		pF
V _{OUT}	Maximum Voltage Swing	Voltage applied to amplifier outputs in charge pump-only mode	1.1	1.0	V _{RMS} (min)

I²C Interface Characteristics $V_{DD} = 3.6V$ (Note 1, Note 2)

The following specifications apply for $A_V = 0dB$, $R_L = 16\Omega$, $f = 1kHz$, unless otherwise specified. Limits apply to $T_A = 25^\circ C$.

Symbol	Parameter	Conditions	LM48824		Units (Limits)
			Typical (Note 7)	Limit (Note 8)	
t_1	SCL Period			2.5	μs (min)
t_2	SDA Setup Time			250	ns (min)
t_3	SDA Stable Time			250	ns (min)
t_4	Start Condition Time			250	ns (min)
t_5	Stop Condition Time			250	ns (min)
V_{IH}	Input High Voltage			1.2	V (min)
V_{IL}	Input Low Voltage			0.6	V (max)

Note 1: "Absolute Maximum Ratings" indicate limits beyond which damage to the device may occur, including inoperability and degradation of device reliability and/or performance. Functional operation of the device and/or non-degradation at the *Absolute Maximum Ratings* or other conditions beyond those indicated in the *Recommended Operating Conditions* is not implied. The *Recommended Operating Conditions* indicate conditions at which the device is functional and the device should not be operated beyond such conditions. All voltages are measured with respect to the ground pin, unless otherwise specified.

Note 2: The *Electrical Characteristics* tables list guaranteed specifications under the listed *Recommended Operating Conditions* except as otherwise modified or specified by the *Electrical Characteristics Conditions* and/or Notes. Typical specifications are estimations only and are not guaranteed.

Note 3: The maximum power dissipation must be derated at elevated temperatures and is dictated by T_{JMAX} , θ_{JA} , and the ambient temperature, T_A . The maximum allowable power dissipation is $P_{DMAX} = (T_{JMAX} - T_A) / \theta_{JA}$ or the number given in *Absolute Maximum Ratings*, whichever is lower.

Note 4: Human body model, applicable std. JESD22-A114C.

Note 5: Machine model, applicable std. JESD22-A115-A.

Note 6: Charged Device Model, applicable std. JESD22-C101-C.

Note 7: Typical values represent most likely parametric norms at $T_A = +25^\circ C$, and at the *Recommended Operation Conditions* at the time of product characterization and are not guaranteed.

Note 8: Datasheet min/max specification limits are guaranteed by test or statistical analysis.

Typical Performance Characteristics

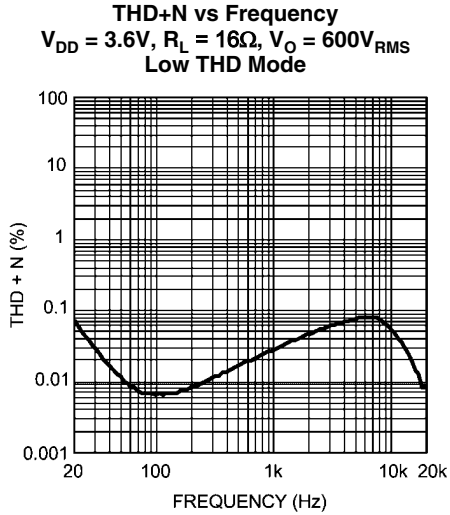

300892b9

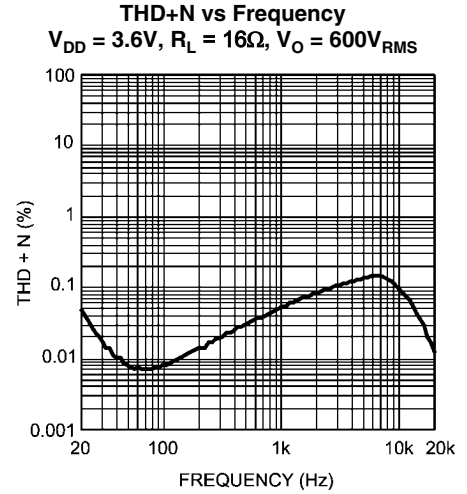

300892c0

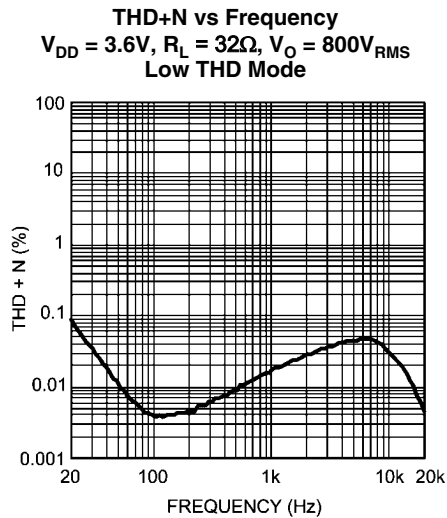

300892c1

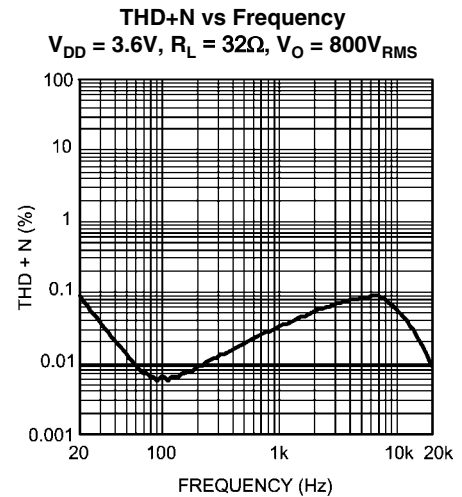

300892c2

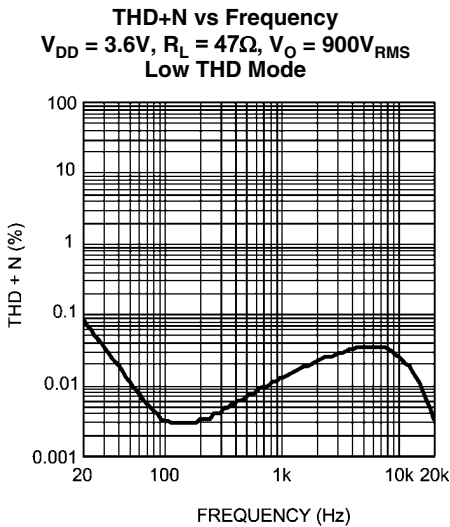

30089224

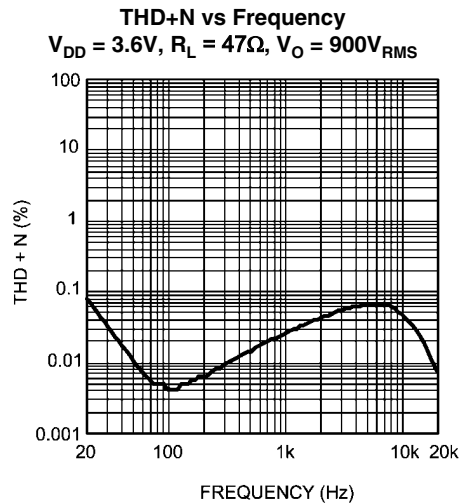

30089225

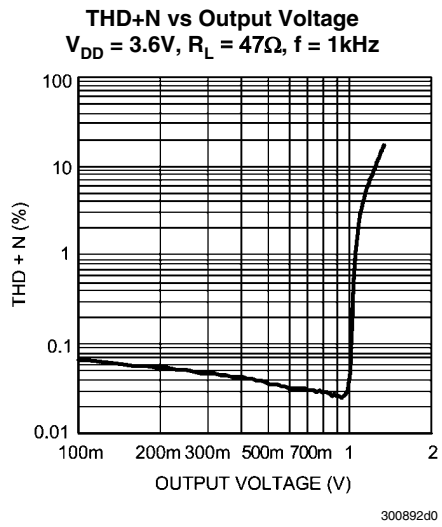
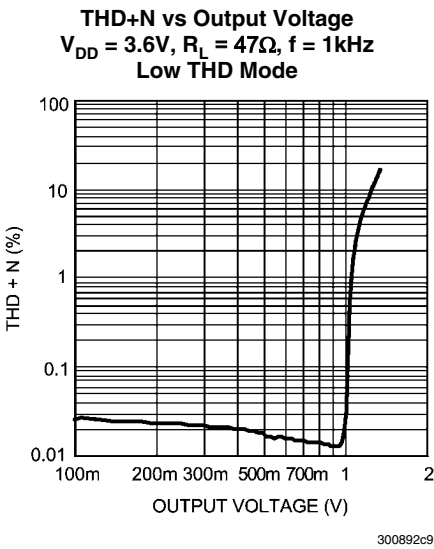
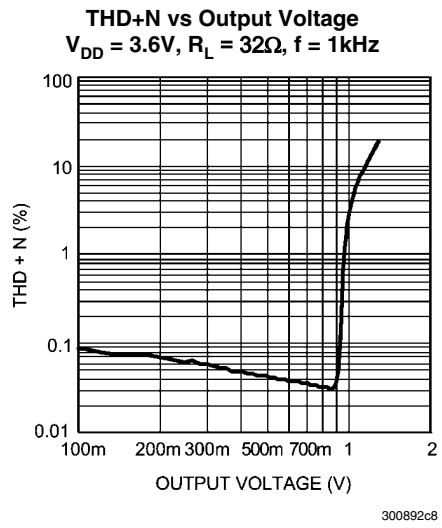
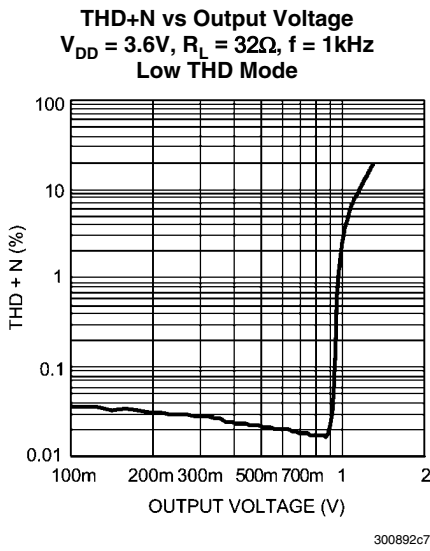
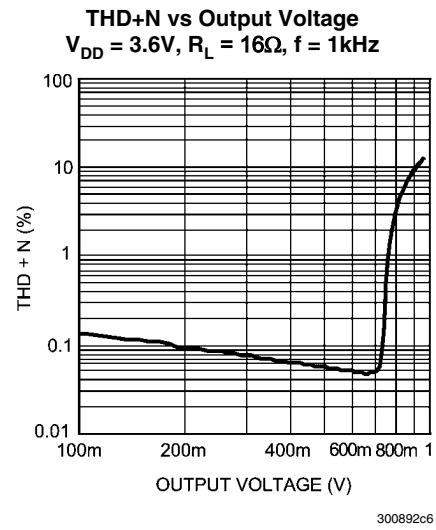
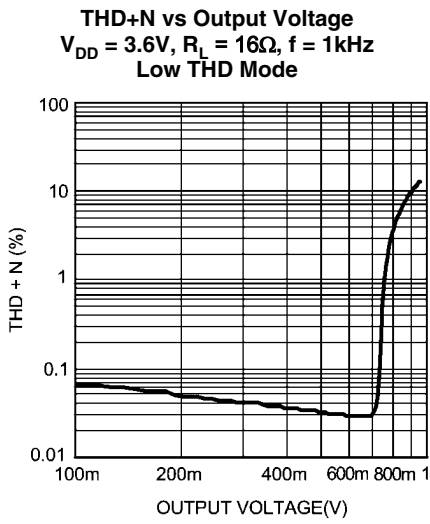

THD+N vs Output Power
 $V_{DD} = 3.6V, R_L = 16\Omega, f = 1kHz$
 Low THD Mode

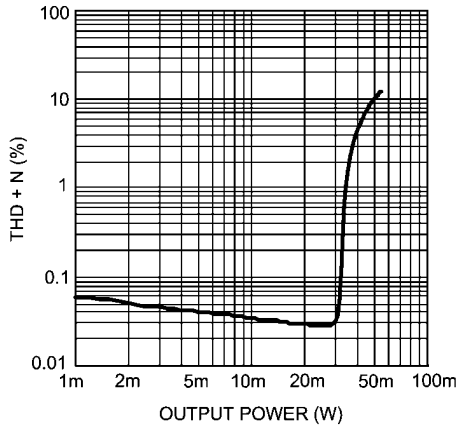

300892d1

THD+N vs Output Power
 $V_{DD} = 3.6V, R_L = 16\Omega, f = 1kHz$

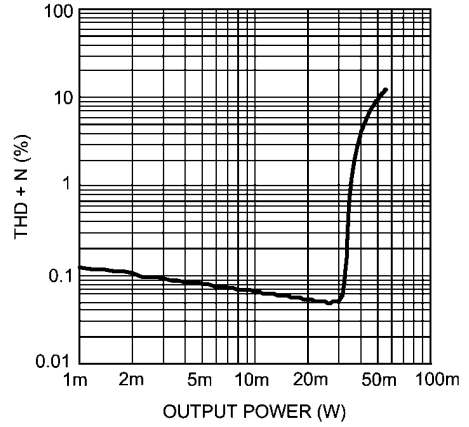

300892d2

THD+N vs Output Power
 $V_{DD} = 3.6V, R_L = 32\Omega, f = 1kHz$
 Low THD Mode

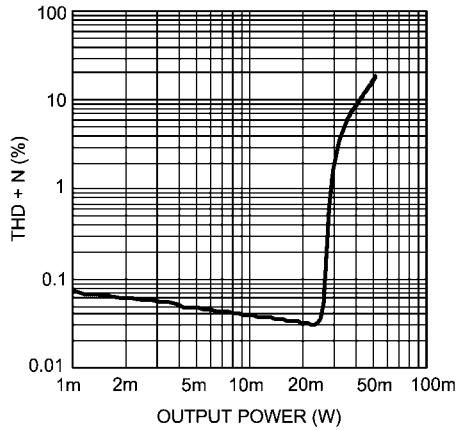

300892d3

THD+N vs Output Power
 $V_{DD} = 3.6V, R_L = 32\Omega, f = 1kHz$

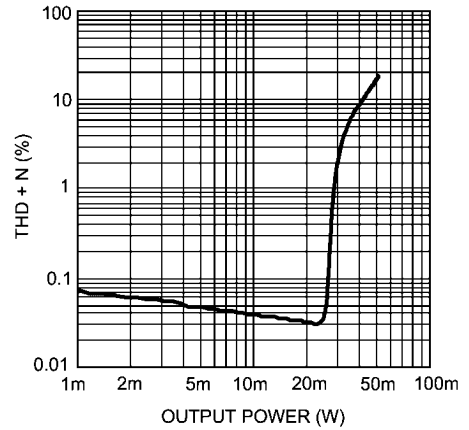

300892d4

Power Dissipation vs Output Power
 $V_{DD} = 3.6V, R_L = 16\Omega, f = 1kHz$

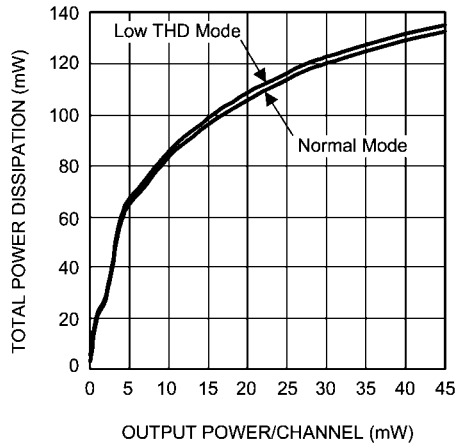

300892d8

Power Dissipation vs Output Power
 $V_{DD} = 3.6V, R_L = 32\Omega, f = 1kHz$

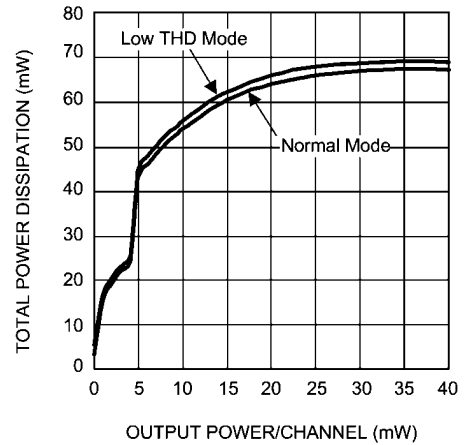

300892d9

Power Dissipation vs Output Power
 $V_{DD} = 3.6V, R_L = 47\Omega, f = 1kHz$

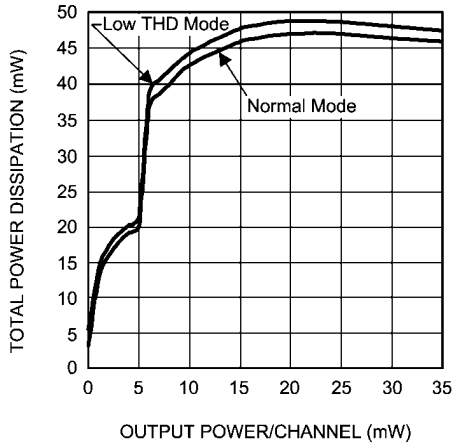

300892e0

Output Power vs Supply Voltage
 $R_L = 16\Omega, f = 1kHz$

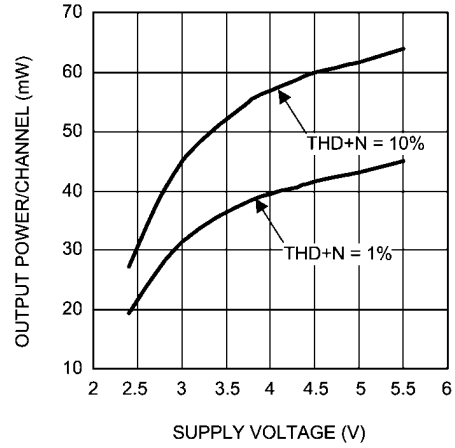

300892e2

Output Power vs Supply Voltage
 $R_L = 32\Omega, f = 1kHz$

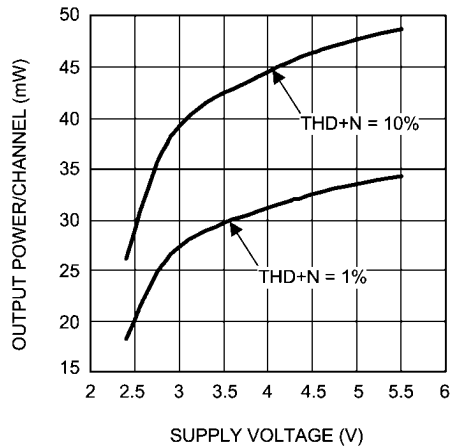

300892e3

Output Power vs Supply Voltage
 $R_L = 47\Omega, f = 1kHz$

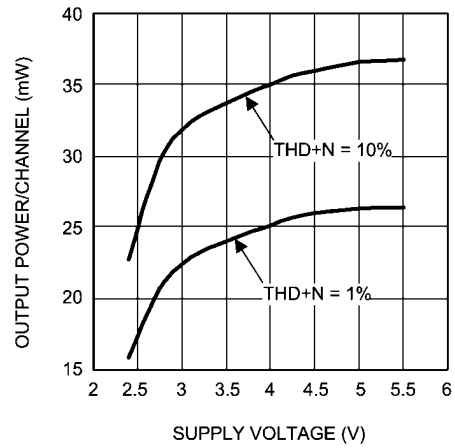

300892e4

Supply Current vs Supply Voltage
 No Load

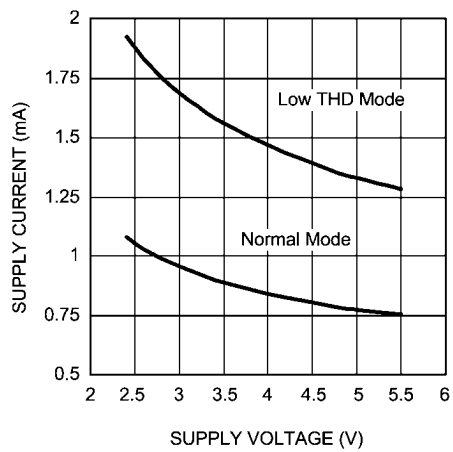

300892e6

CMRR vs Frequency
 $V_{DD} = 3.6V, V_{RIPPLE} = 1V_{P-P}, R_L = 32\Omega$

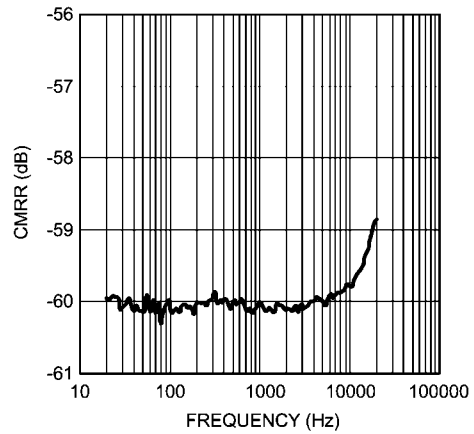

300892h7

PSRR vs Frequency
 $V_{DD} = 3.6V$, $V_{RIPPLE} = 200V_{P-P}$
 $R_L = 32\Omega$

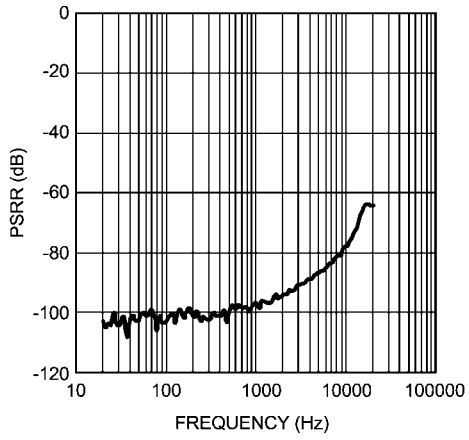

300892h8

Crosstalk vs Frequency
 $V_{DD} = 3.6V$, $P_O = 5mW$
 $R_L = 32\Omega$

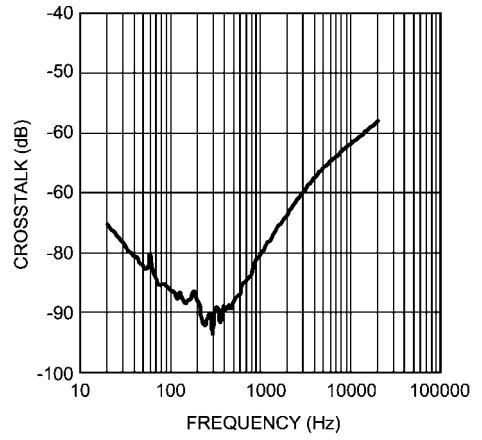

300892h9

Application Information

I²C COMPATIBLE INTERFACE

The LM48824 is controlled through an I²C compatible serial interface that consists of a serial data line (SDA) and a serial clock (SCL). The clock line is uni-directional. The data line is bi-directional (open drain). The LM48824 and the master can communicate at clock rates up to 400kHz. Figure 2 shows the I²C interface timing diagram. Data on the SDA line must be stable during the HIGH period of SCL. The LM48824 is a transmit/receive slave-only device, reliant upon the master to generate the SCL signal. Each transmission sequence is framed by a START condition and a STOP condition (Figure 3). Each data word, device address and data, transmitted over the bus is 8 bits long and is always followed by an acknowledge pulse (Figure 4). The LM48824 device address is 1100000.

I²C BUS FORMAT

The I²C bus format is shown in Figure 4. The START signal, the transition of SDA from HIGH to LOW while SCL is HIGH, is generated, alerting all devices on the bus that a device address is being written to the bus.

The 7-bit device address is written to the bus, most significant bit (MSB) first, followed by the R/W bit (R/W = 0 indicates the master is writing to the LM48824, R/W = 1 indicates the master wants to read data from the LM48824). Data is latched into the device on the rising clock edge. Each address bit must be stable while SCL is HIGH. After the last address bit is transmitted, the master device releases SDA, during which time, an acknowledge clock pulse is generated by the slave device. If the LM48824 receives the correct address, the device pulls the SDA line low, generating an acknowledge bit (ACK).

Once the master device registers the ACK bit, the 8-bit register address word is sent. Each data bit should be stable while SCL is HIGH. After the 8-bit register address is sent, the LM48824 sends another ACK bit. Following the acknowledgement of the register address, the 8-bit register data word is sent. Each data bit should be stable while SCL is HIGH. After the 8-bit register data is sent, the LM48824 sends another ACK bit. Following the acknowledgement of the register data word, the master issues a STOP bit, allowing SDA to go high while SCL is high.

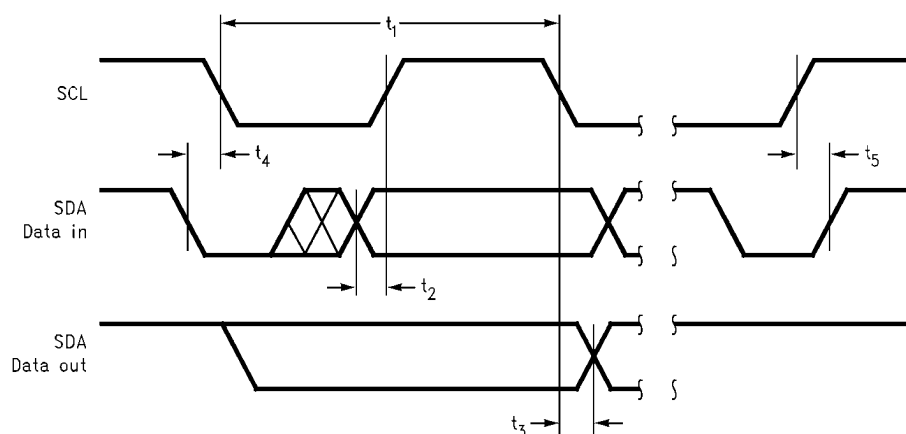

30089201

FIGURE 2. I²C Timing Diagram

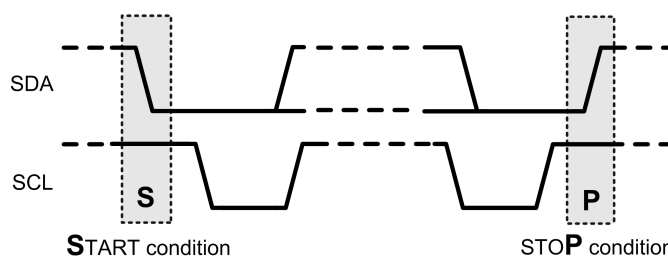

30089202

FIGURE 3. Start and Stop Diagram

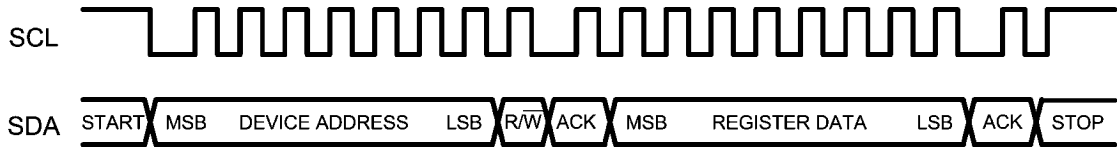

30089214

FIGURE 4. I²C Write Cycle

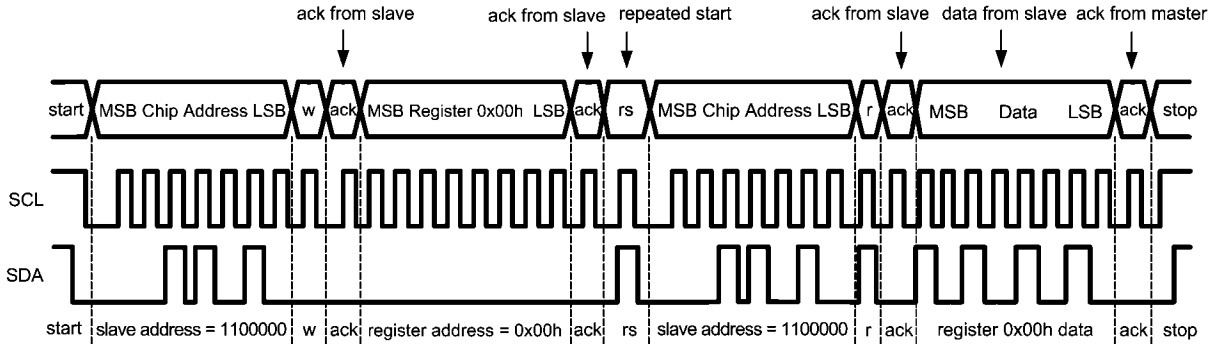

30089269

FIGURE 5. Example I²C Read Cycle

TABLE 1. Device Address

	B7	B6	B5	B4	B3	B2	B1	B0 (R/W)
Device Address	1	1	0	0	0	0	0	X

TABLE 2. I²C Control Registers (Note 9)

Register Address	Register Name	B7	B6	B5	B4	B3	B2	B1	B0
0x01h	MODE CONTROL	HPL_EN	HPR_EN	0	0	0	0	THRM	SHDN
0x02h	VOLUME CONTROL	MUTE_L*	MUTE_R*	VOL4	VOL3	VOL2	VOL1	VOL0	0
0x03h	OUTPUT CONTROL	0	0	0	0	LOW_THD	0	HiZ_L	HiZ_R
0x04h	DEVICE INFORMATION (Read-Only)	0	1	0	0	0	0	0	0

Note 9: * All registers default to 0 on initial power-up except SHDN, MUTE_L, MUTE_R bits default to 1 at power-up.

TABLE 3. Mode Control Register

Bit	Name	Value	Description
B0	SHDN	0	Device enabled
		1	Device disabled
B1	THRM (Read Only)	0	Thermal-protection inactive
		1	Thermal-protection active
B6	HPR_EN	0	Right channel amplifier disabled
		1	Right channel amplifier enabled
B7	HPL_EN	0	Left channel amplifier disabled
		1	Left channel amplifier enabled

TABLE 4. Volume Control Register

Bit	Name	Value	Description
B5:B1	VOL4:VOL0		These bits set the volume level. See Table 5 (Volume Control).
B6	MUTE_R	0	Right Channel Mute Disabled
		1	Right Channel Mute Enabled
B7	MUTE_L	0	Left Channel Mute Disabled
		1	Left Channel Mute Enabled

TABLE 5. Volume Control

Volume Step	VOL4	VOL3	VOL2	VOL1	VOL0	HP Gain (dB)
0	0	0	0	0	0	-59
1	0	0	0	0	1	-55
2	0	0	0	1	0	-51
3	0	0	0	1	1	-47
4	0	0	1	0	0	-43
5	0	0	1	0	1	-39
6	0	0	1	1	0	-35
7	0	0	1	1	1	-31
8	0	1	0	0	0	-27
9	0	1	0	0	1	-25
10	0	1	0	1	0	-23
11	0	1	0	1	1	-21
12	0	1	1	0	0	-19
13	0	1	1	0	1	-17
14	0	1	1	1	0	-15
15	0	1	1	1	1	-13
16	1	0	0	0	0	-11
17	1	0	0	0	1	-10
18	1	0	0	1	0	-9
19	1	0	0	1	1	-8
20	1	0	1	0	0	-7
21	1	0	1	0	1	-6
22	1	0	1	1	0	-5
23	1	0	1	1	1	-4
24	1	1	0	0	0	-3
25	1	1	0	0	1	-2
26	1	1	0	1	0	-1
27	1	1	0	1	1	0
28	1	1	1	0	0	1
29	1	1	1	0	1	2
30	1	1	1	1	0	3
31	1	1	1	1	1	4

TABLE 6. Output Control Register

Bit	Name	Value	Description
B0	HiZ_R	0	Right channel high impedance mode disabled
		1	Right channel high impedance mode enabled
B1	HiZ_L	0	Left channel high impedance mode disabled
		1	Left channel high impedance mode enabled
B3	LOW_THD	0	LOW_THD mode disabled
		1	LOW_THD mode enabled, improves overall THD

GENERAL DEVICE FUNCTION

The LM48824 integrates a high efficiency step down (buck) DC-DC switching regulator with a ground reference headphone amplifier. The switching regulator delivers a constant voltage from an input voltage ranging from 2.4V to 5.5V. The switching regulator uses a voltage-mode architecture with synchronous rectification, improving efficiency and reducing component count.

The LM48824 headphone amplifier features National's ground referenced architecture that eliminates the large DC-blocking capacitors required at the outputs of traditional single-ended headphone amplifiers. A low-noise inverting charge pump creates a negative supply (HPV_{SS}) from the positive supply voltage (V_{DD}). The headphone amplifiers operate from these bipolar supplies, with the amplifier outputs biased about GND. Because there is no DC component on the output signals, the large DC-blocking, AC coupling capacitors (typically 220µF) are not necessary, conserving board space, reducing system cost, and improving frequency response.

CLASS G OPERATION

Class G is a modification of some other class of amplifier (normally Class B or Class AB) to increase efficiency and reduce power dissipation. Class G works off the fact that musical and voice signals have a high peak to mean ratio with most of the signal content at low levels. To decrease power dissipation, Class G has multiple voltage supplies. The LM48824 has two discrete voltage supplies at the output of the buck, 1.1V and 1.8V. When the output reached the threshold to switch to the higher voltage rails, the rails will switch from 1.1V to 1.8V. When the output falls below the required voltage rails for a set period of time, it will switch back to the lower rail until the next time the threshold is reached. Power dissipation is greatly reduced for typical musical or voice sources. The drawing below shows how a musical output may look. The green lines are the supply voltages at the output of the buck converter.

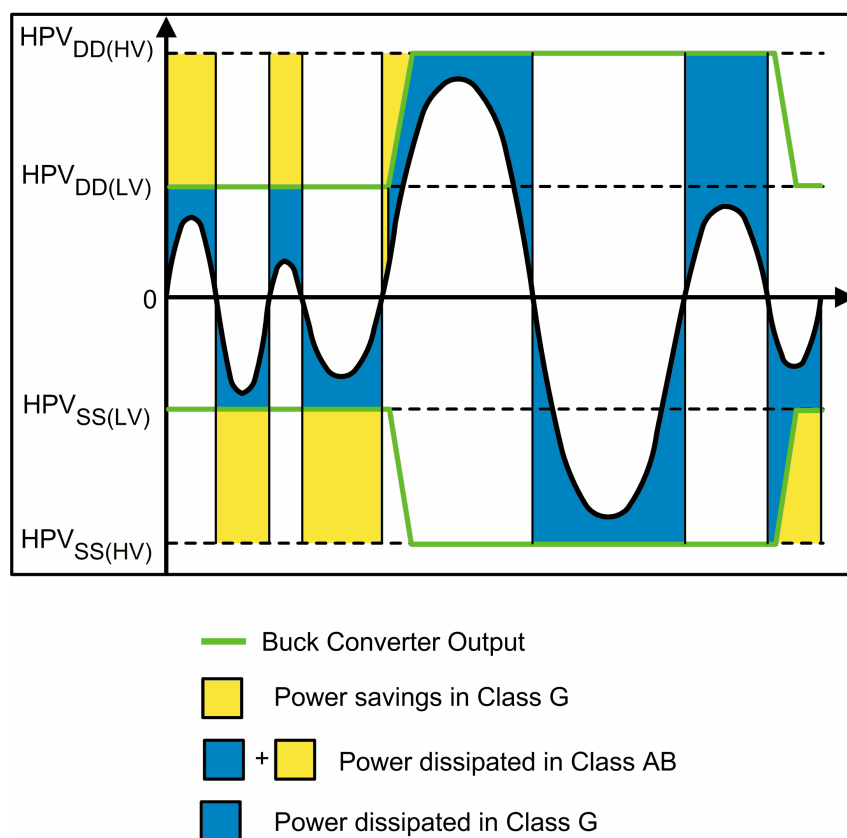

30089248

FIGURE 6. Class G Operation

DIFFERENTIAL AMPLIFIER EXPLANATION

The LM48824 features a differential input stage, which offers improved noise rejection compared to a single-ended input amplifier. Because a differential input amplifier amplifies the difference between the two input signals, any component common to both signals is cancelled.

SYNCHRONOUS RECTIFIER

The buck converter in the LM48824 uses an internal NFET synchronous rectifier to reduce rectifier forward voltage drop and associated power loss. Synchronous rectification provides a significant improvement in efficiency whenever the output voltage is relative low compared to the voltage drop across an ordinary rectifier diode and eliminating the need for the diode.

CURRENT LIMITING

A current limit of the buck converter in the LM48824 allows the device to protect itself and external components during overload conditions.

PFM OPERATION

During PFM(Pulse-Frequency Modulation) operation, if the output voltage of the buck converter is below the 'high' PFM comparator threshold, the PMOS power switch is turned on. It remains on until the output voltage reaches the 'high' PFM threshold or the peak current exceeds the I_{PFM} level set for PFM mode. The typical peak current in PFM mode is $I_{PFM} = 112\text{mA} + V_{DD}/27\Omega$.

Once the PMOS power switch is turned off, the NMOS power switch is turned on until the inductor current ramps to zero. When the NMOS zero-current condition is detected, the NMOS power switch is turned off. If the output voltage is below the 'high' PFM comparator threshold, the PMOS switch is again turned on and the cycle is repeated until the output reaches the desired level. Once the output reaches the 'high' PFM threshold, the NMOS switch is turned on briefly to ramp the inductor current to zero and then both output switches are turned off and the part enters an extremely low power mode.

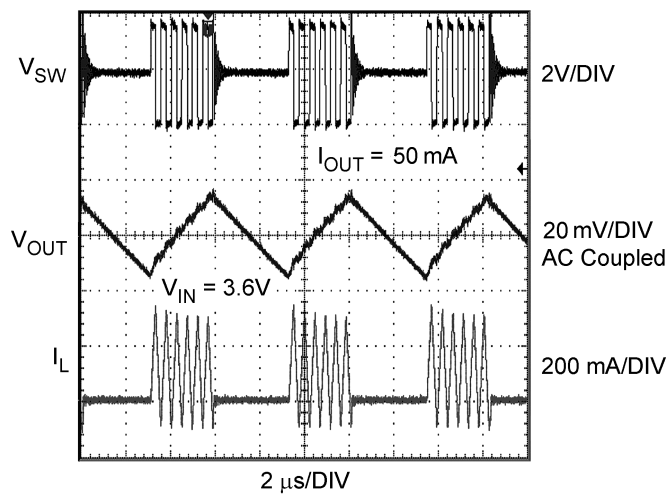

30089205

FIGURE 7. PFM Operation

SOFT START

The buck converter has a soft-start circuit that limits in-rush current during start-up. During start-up the switch current limit is increased in steps. Soft start is activated only if global SHDN goes from 1 to 0 after V_{DD} reaches 2.7V. Soft start is implemented by increasing switch current limit in steps of 70mA, 140mA, 280mA, and 750mA (typical switch current limit). The start-up time thereby depends on the output capacitor and load current of the buck converter. Typical start-up times with a 10 μ F output capacitor and 150mA load is 280 μ s and with 5mA load is 240 μ s.

COMMON-MODE SENSE

The LM48824 features a ground (common mode) sensing feature. In noisy applications, or where the headphone jack is

used as a line out to other devices, noise pick up and ground imbalance can degrade audio quality. The LM48824 COM input senses and corrects any noise at the headphone return, or any ground imbalance between the headphone return and device ground, improving audio reproduction. Connect COM directly to the headphone return terminal of the headphone jack (Figure 8). No additional external components are required. Connect COM to GND if the common-mode sense feature is not in use.

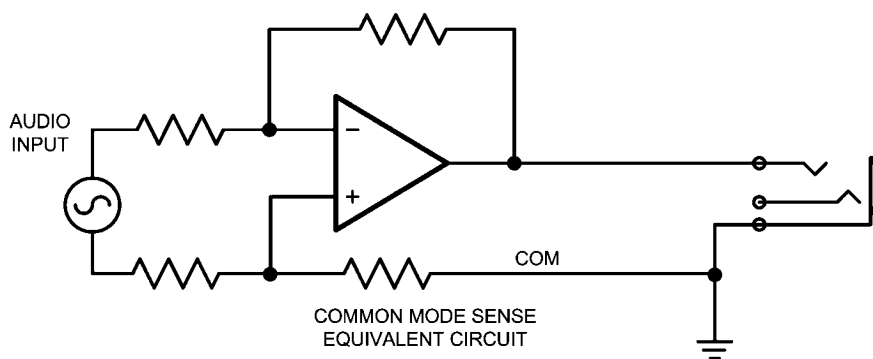

30089206

FIGURE 8. COM Connection

SHUTDOWN FUNCTION

The LM48824 features individual amplifier shutdown control and a global device shutdown control.

Bit B0 (SHDN) of the MODE CONTROL register controls the global shutdown for the entire device. Set SHDN = 1 to put the device into current-saving shutdown mode, and set SHDN = 0 for normal operation. SHDN defaults to 1 at power-up.

Bit B7 (HPL_EN) and Bit B6 (HPR_EN) of the MODE CONTROL register (register address 0x01h) controls the left and right headphone amplifier shutdown respectively. Set HPL_EN = 0 to set the left channel headphone amplifier to shutdown and set HPL_EN = 1 to enable left channel operation. Set HPR_EN = 0 to set the right channel headphone amplifier to shutdown and set HPR_EN = 1 to enable right channel operation. The left and right channel amplifier shutdowns operate individually.

The LM48824 has a shutdown time of 3ms to complete the internal shutdown sequence. After SHDN is set to 1, any new I²C commands should only be sent after the 3ms shutdown time to ensure proper operation of the device.

MUTE FUNCTION

The LM48824 features independent left and right channel mute functions.

Bit B7 (MUTE_L) and Bit B6 (MUTE_R) of the VOLUME CONTROL register (register address 0x02h) controls the mute function of the left and right channels respectively. Set MUTE_L = 1 to mute the left channel and set the MUTE_R = 1 to mute the right channel. Set MUTE_L = 0 and MUTE_R = 0 to disable mute on the respective channels. MUTE_L and MUTE_R defaults to 1 at power-up.

LOW THD+N MODE

The LM48824 features a Low THD mode that reduces THD +N to improve audio quality. Set B3 (Low_THD) of the OUTPUT CONTROL register (register address 0x03h) to 1 to enable the Low THD mode. There is a quiescent and operating current increase in Low THD mode. See Electrical Characteristics table and Typical Performance Characteristics for reference.

PROPER SELECTION OF EXTERNAL COMPONENTS

INDUCTOR SELECTION

There are two main considerations when choosing an inductor; the inductor saturation current and the inductor current

ripple should be small enough to achieve the desired output voltage ripple. Different saturation current rating specifications are followed by different manufacturers so attention must be given to details. Saturation current ratings are typically specified at 25°C, ratings at the maximum ambient temperature of application should be requested from the manufacturer. Shielded capacitors are preferred since these capacitors radiate less noise. Inductors with low DCR should also be considered to minimize the efficiency.

Inductor value involves trade-offs in performance. Larger inductors reduce inductor triple current, which typically means less output voltage ripple (for a given size of output capacitor).

REGULATOR INPUT CAPACITOR SELECTION (C3)

A ceramic input capacitor of 1 μ F, 6.3V is sufficient for most applications. Place the input capacitor as close as possible to the V_{DD} pin of the device. A larger value may be used for improved input voltage filtering. Use X7R or X5R types; do not use Y5V. DC bias characteristics of ceramic capacitors must be considered when selecting case sizes like 0805 and 0603.

REGULATOR OUTPUT CAPACITOR SELECTION (C4)

A low ESR ceramic output capacitor of 10 μ F, 6.3V is sufficient for most applications. Use X7R or X5R types; do not use Y5V. DC bias characteristics of ceramic capacitors must be considered when selecting case sizes like 0805 and 0603. DC bias characteristics vary from manufacturer to manufacturer and dc bias curves should be requested from them as part of the capacitor selection process.

CHARGE PUMP CAPACITOR SELECTION

Use low ESR ceramic capacitors (less than 100m Ω) for optimum performance.

CHARGE PUMP FLYING CAPACITOR (C1)

The flying capacitor (C1) affects the load regulation and output impedance of the charge pump. A C1 value that is too low results in a loss of current drive, leading to a loss of amplifier headroom. A higher valued C1 improves load regulation and lowers charge pump output impedance to an extent. Above 2.2 μ F, the R_{DS(ON)} of the charge pump switches and the ESR of C1 and C2 dominate the output impedance. A lower value capacitor can be used in systems with low maximum output power requirements.

CHARGE PUMP HOLD CAPACITOR (C2)

The value and ESR of the hold capacitor (C2) directly affects the ripple on CPV_{SS} . Increasing the value of C2 reduces output ripple. Decreasing the ESR of C2 reduces both output ripple and charge pump output impedance. A lower value capacitor can be used in systems with low maximum output power requirements.

Amplifier Input Capacitor Selection

Input capacitors may be required for some applications, or when the audio source is single-ended. Input capacitors block the DC component of the audio signal, eliminating any conflict between the DC component of the audio source and the bias voltage of the LM48824. The input capacitors create a high-pass filter with the input resistors R_{IN} . The -3dB point of the high-pass filter is found using Equation (1) below.

$$f = 1 / 2\pi R_{IN} C_{IN} \text{ (Hz)} \quad (1)$$

Where the value of R_{IN} is given in the Electrical Characteristics Table.

High-pass filtering the audio signal can be beneficial for some applications. When the LM48824 is using a single-ended source, power supply noise on the ground is seen as an input signal. Setting the high-pass filter point above the power supply noise frequencies, 217Hz in a GSM phone, for example, filters out the noise such that it is not amplified and heard on the output. Capacitors with a tolerance of 10% or better are recommended for impedance matching and improved CMRR and PSRR.

SINGLE-ENDED AUDIO AMPLIFIER CONFIGURATION

The LM48824 is compatible with single-ended sources. Figure 9 shows the typical single-ended applications circuit. Input coupling capacitors are required for single-ended configuration.

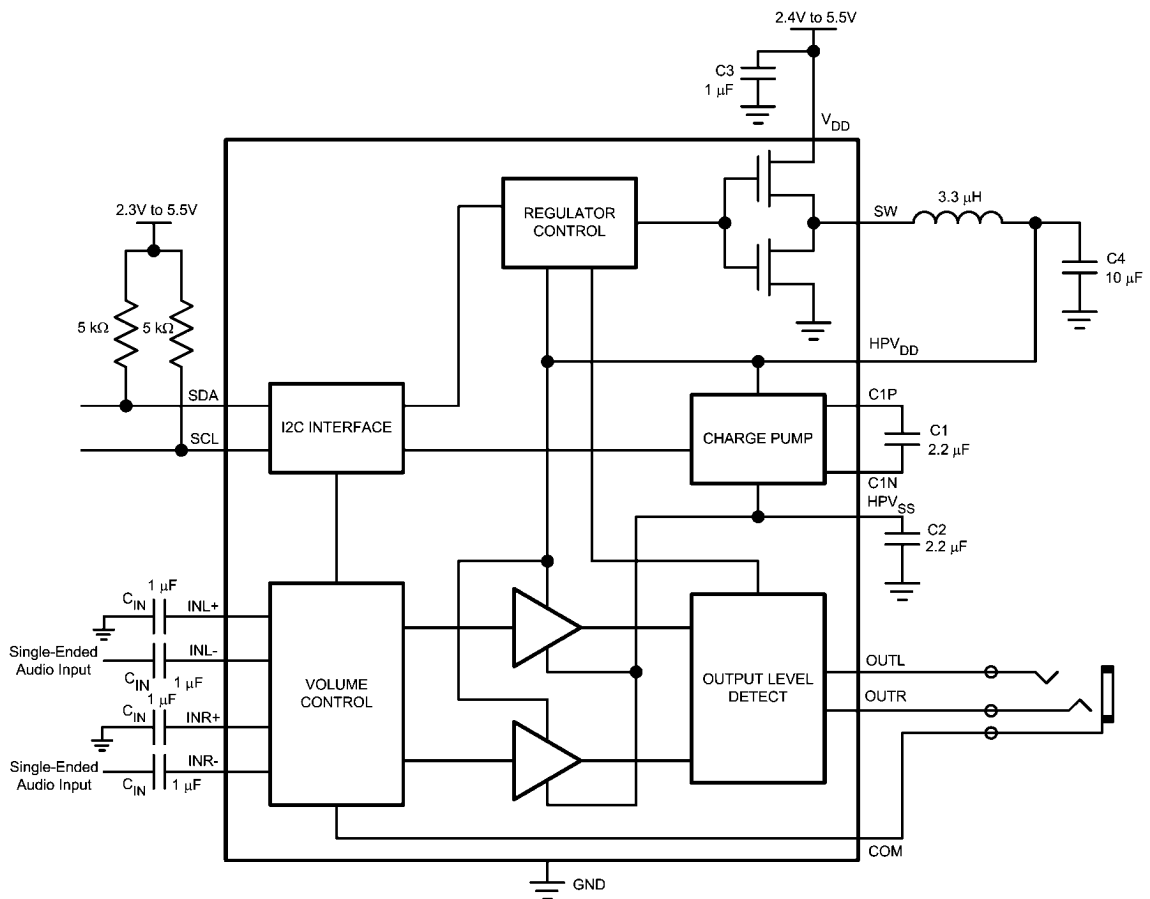

30089250

FIGURE 9. Single-Ended Input Configuration

PCB LAYOUT CONFIGURATION

TABLE 7. LM48824TM Demoboard Bill of Materials

Designator	Quantity	Description
C1	1	10 μ F \pm 10% 16V 500 Ω Tantalum Capacitor (B Case) AVX TPSB106K016R0500
C2	1	1 μ F \pm 10% 16V X5R Ceramic Capacitor (603) Panasonic ECJ-1VB1C105K
C3, C8, C9	3	2.2 μ F \pm 10% 10V X5R Ceramic Capacitor (603) Panasonic ECJ-1VB1A225K
C4 – C7	4	1 μ F \pm 10% 16V X7R Ceramic Capacitor (1206) Panasonic ECJ-3YB1C105K
R1, R2	2	5k Ω \pm 5% 1/10W Thick Film Resistor (603) Vishay CRCW06035R1KJNEA
L1	1	3.3 μ H \pm 30% 1.2A Inductor Murata LQM2MPN3R3NG0L
J1	1	Stereo Headphone Jack
J2	1	16-Pin Boardmount Socket 3M 8516-4500JL
JU1	1	3 Pin Header
JU2	1	2 Pin Header
LM4822TM	1	LM48824TM (16-Bump microSMD)

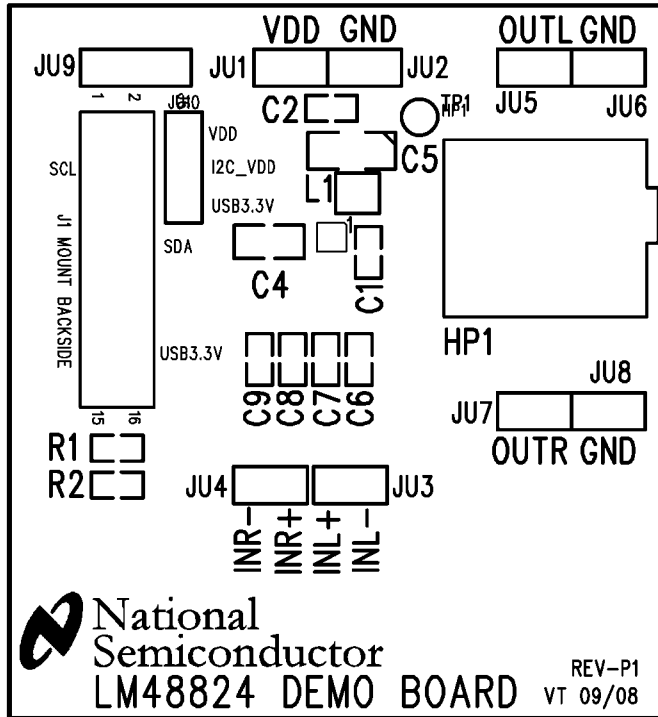

300892h5

FIGURE 11. Top Silkscreen

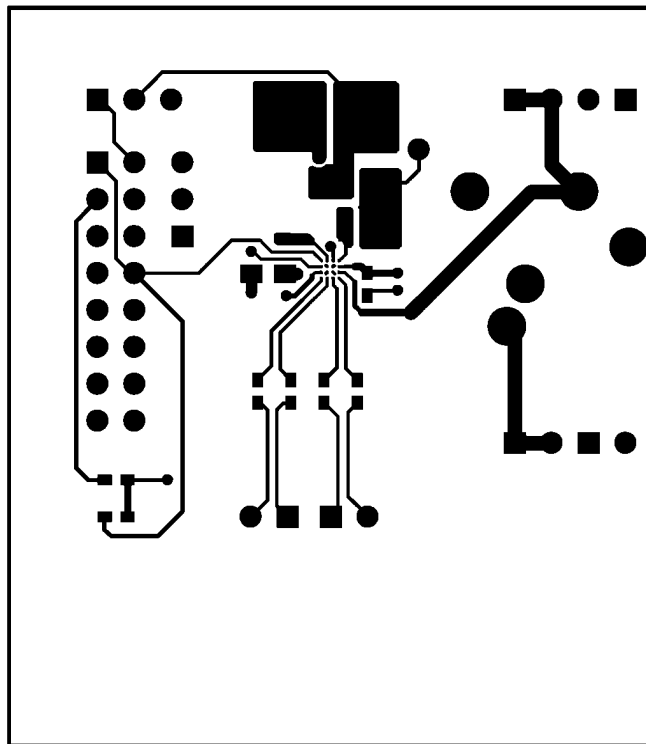

300892h1

FIGURE 12. Top Layer

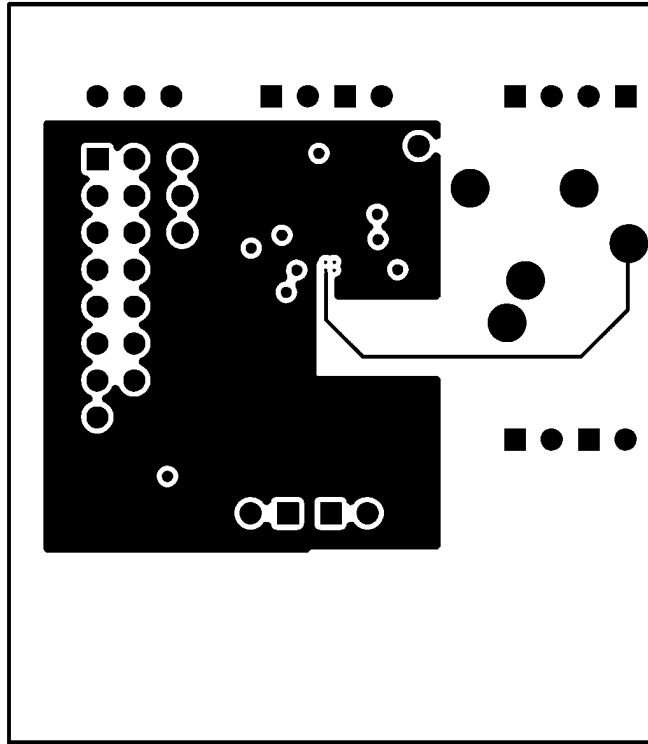

300892h2

FIGURE 13. Layer 2 (GND)

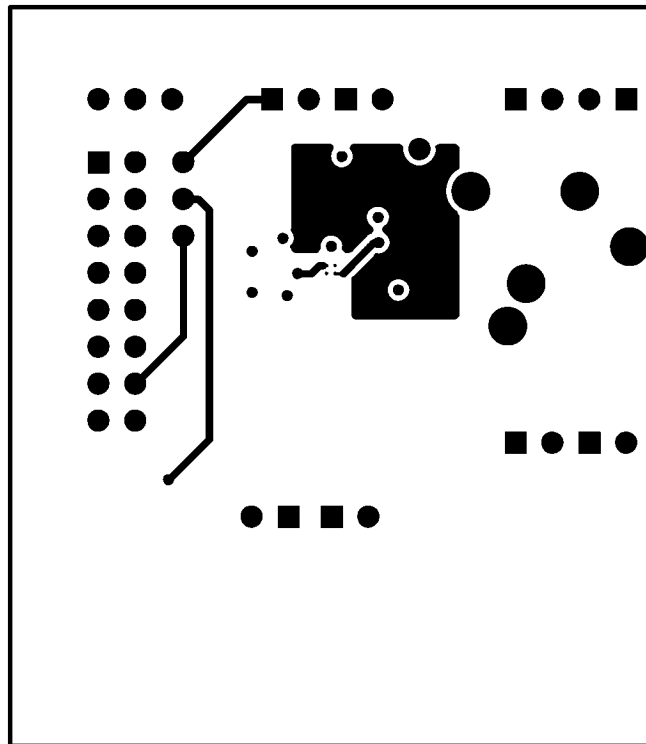

300892h3

FIGURE 14. Layer 3 (VDD)

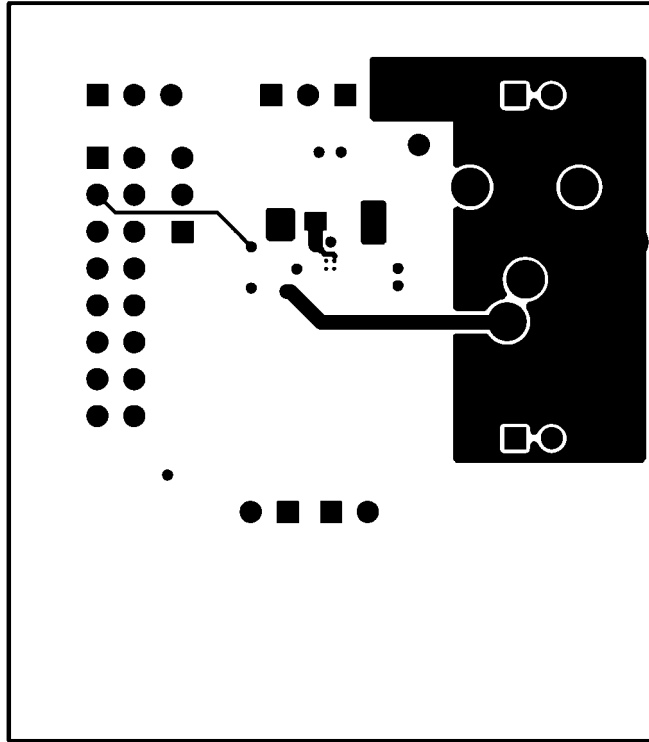

300892h4

FIGURE 15. Bottom Layer

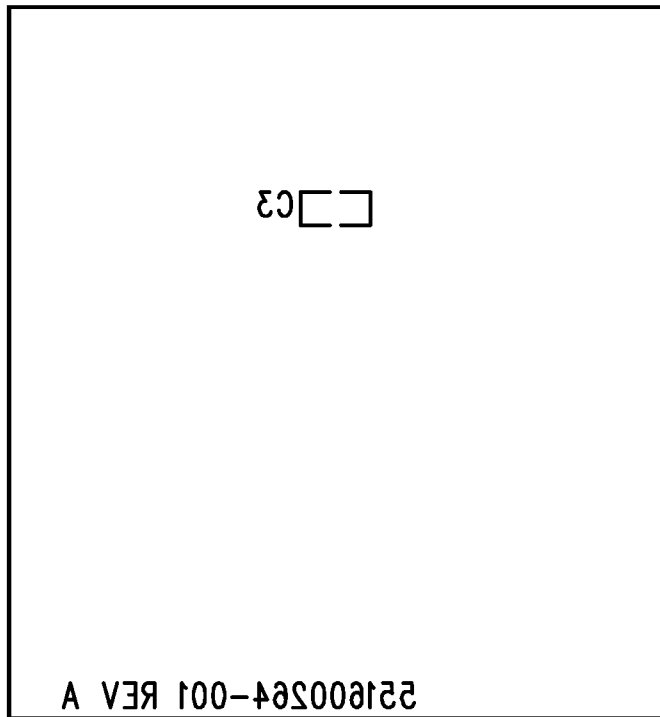

300892h0

FIGURE 16. Bottom Silkscreen

Revision History

Rev	Date	Description
1.0	08/06/09	Initial released of the full datasheet.
1.01	08/31/09	Text edits.

Physical Dimensions inches (millimeters) unless otherwise noted

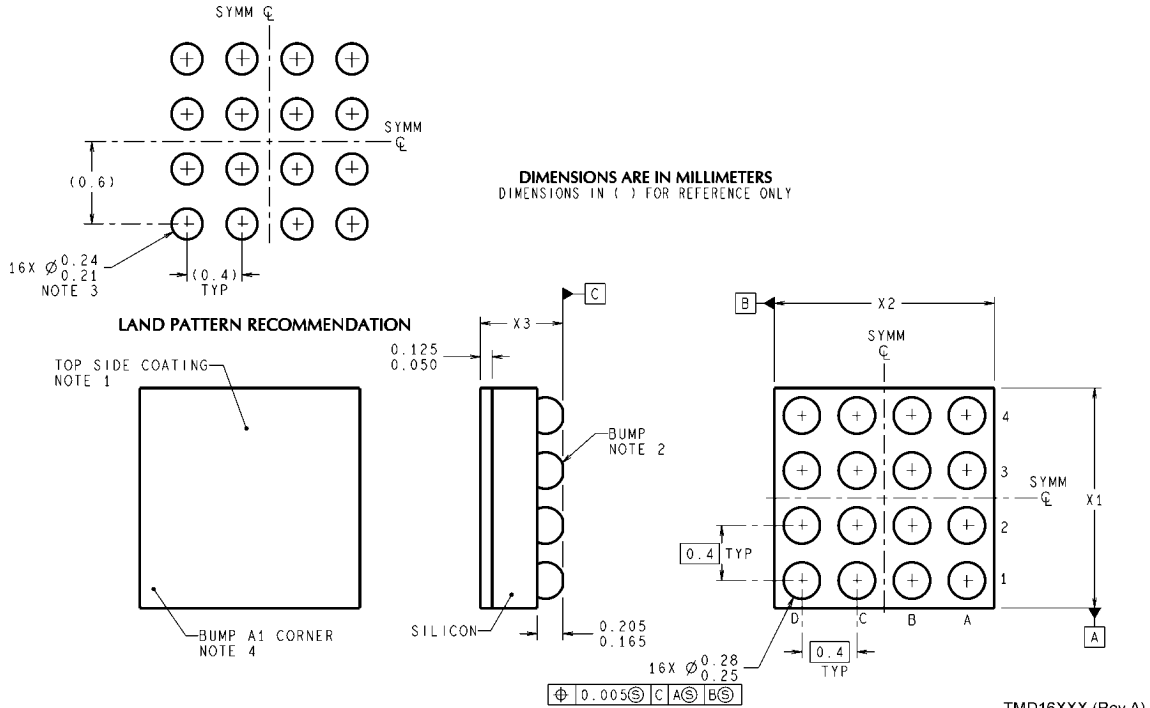

Notes

For more National Semiconductor product information and proven design tools, visit the following Web sites at:

Products		Design Support	
Amplifiers	www.national.com/amplifiers	WEBENCH® Tools	www.national.com/webench
Audio	www.national.com/audio	App Notes	www.national.com/appnotes
Clock and Timing	www.national.com/timing	Reference Designs	www.national.com/refdesigns
Data Converters	www.national.com/adc	Samples	www.national.com/samples
Interface	www.national.com/interface	Eval Boards	www.national.com/evalboards
LVDS	www.national.com/lvds	Packaging	www.national.com/packaging
Power Management	www.national.com/power	Green Compliance	www.national.com/quality/green
Switching Regulators	www.national.com/switchers	Distributors	www.national.com/contacts
LDOs	www.national.com/ldo	Quality and Reliability	www.national.com/quality
LED Lighting	www.national.com/led	Feedback/Support	www.national.com/feedback
Voltage Reference	www.national.com/vref	Design Made Easy	www.national.com/easy
PowerWise® Solutions	www.national.com/powerwise	Solutions	www.national.com/solutions
Serial Digital Interface (SDI)	www.national.com/sdi	Mil/Aero	www.national.com/milaero
Temperature Sensors	www.national.com/tempensors	SolarMagic™	www.national.com/solarmagic
Wireless (PLL/VCO)	www.national.com/wireless	PowerWise® Design University	www.national.com/training

THE CONTENTS OF THIS DOCUMENT ARE PROVIDED IN CONNECTION WITH NATIONAL SEMICONDUCTOR CORPORATION ("NATIONAL") PRODUCTS. NATIONAL MAKES NO REPRESENTATIONS OR WARRANTIES WITH RESPECT TO THE ACCURACY OR COMPLETENESS OF THE CONTENTS OF THIS PUBLICATION AND RESERVES THE RIGHT TO MAKE CHANGES TO SPECIFICATIONS AND PRODUCT DESCRIPTIONS AT ANY TIME WITHOUT NOTICE. NO LICENSE, WHETHER EXPRESS, IMPLIED, ARISING BY ESTOPPEL OR OTHERWISE, TO ANY INTELLECTUAL PROPERTY RIGHTS IS GRANTED BY THIS DOCUMENT.

TESTING AND OTHER QUALITY CONTROLS ARE USED TO THE EXTENT NATIONAL DEEMS NECESSARY TO SUPPORT NATIONAL'S PRODUCT WARRANTY. EXCEPT WHERE MANDATED BY GOVERNMENT REQUIREMENTS, TESTING OF ALL PARAMETERS OF EACH PRODUCT IS NOT NECESSARILY PERFORMED. NATIONAL ASSUMES NO LIABILITY FOR APPLICATIONS ASSISTANCE OR BUYER PRODUCT DESIGN. BUYERS ARE RESPONSIBLE FOR THEIR PRODUCTS AND APPLICATIONS USING NATIONAL COMPONENTS. PRIOR TO USING OR DISTRIBUTING ANY PRODUCTS THAT INCLUDE NATIONAL COMPONENTS, BUYERS SHOULD PROVIDE ADEQUATE DESIGN, TESTING AND OPERATING SAFEGUARDS.

EXCEPT AS PROVIDED IN NATIONAL'S TERMS AND CONDITIONS OF SALE FOR SUCH PRODUCTS, NATIONAL ASSUMES NO LIABILITY WHATSOEVER, AND NATIONAL DISCLAIMS ANY EXPRESS OR IMPLIED WARRANTY RELATING TO THE SALE AND/OR USE OF NATIONAL PRODUCTS INCLUDING LIABILITY OR WARRANTIES RELATING TO FITNESS FOR A PARTICULAR PURPOSE, MERCHANTABILITY, OR INFRINGEMENT OF ANY PATENT, COPYRIGHT OR OTHER INTELLECTUAL PROPERTY RIGHT.

LIFE SUPPORT POLICY

NATIONAL'S PRODUCTS ARE NOT AUTHORIZED FOR USE AS CRITICAL COMPONENTS IN LIFE SUPPORT DEVICES OR SYSTEMS WITHOUT THE EXPRESS PRIOR WRITTEN APPROVAL OF THE CHIEF EXECUTIVE OFFICER AND GENERAL COUNSEL OF NATIONAL SEMICONDUCTOR CORPORATION. As used herein:

Life support devices or systems are devices which (a) are intended for surgical implant into the body, or (b) support or sustain life and whose failure to perform when properly used in accordance with instructions for use provided in the labeling can be reasonably expected to result in a significant injury to the user. A critical component is any component in a life support device or system whose failure to perform can be reasonably expected to cause the failure of the life support device or system or to affect its safety or effectiveness.

National Semiconductor and the National Semiconductor logo are registered trademarks of National Semiconductor Corporation. All other brand or product names may be trademarks or registered trademarks of their respective holders.

Copyright© 2009 National Semiconductor Corporation

For the most current product information visit us at www.national.com



**National Semiconductor
Americas Technical
Support Center**
Email: support@nsc.com
Tel: 1-800-272-9959

**National Semiconductor Europe
Technical Support Center**
Email: europe.support@nsc.com

**National Semiconductor Asia
Pacific Technical Support Center**
Email: ap.support@nsc.com

**National Semiconductor Japan
Technical Support Center**
Email: jpn.feedback@nsc.com