

September 1995

DESCRIPTION

The SSI 32P4903 is a high performance BiCMOS read channel IC that provides all of the functions needed to implement an entire Partial Response Class 4 (PR4) read channel for zoned recording hard disk drive systems with data rates from 24 to 80 Mbit/s.

Functional blocks include AGC, programmable filter, adaptive transversal filter, Viterbi qualifier, 8,9 GCR ENDEC, data synchronizer, time base generator, and 4-burst servo capture.

Programmable functions such as data rate, filter cutoff, filter boost, etc., are controlled by writing to the serial port registers so no external component changes are required to change zones.

The SSI 32P4903 utilizes an advanced BiCMOS process technology along with advanced circuit design techniques which result in high performance devices with low power consumption. The part requires a single +5V power supply.

FEATURES

GENERAL

- Register programmable data rates from 24 to 80 Mbit/s
- Sampled data read channel with Viterbi qualification
- Programmable filter for PR4 equalization
- Three tap transversal filter for adaptive PR4 equalization
- 8/9 GCR ENDEC
- Data Scrambler/Descrambler
- Programmable write precompensation
- Low operating power (0.75W typical at 5V)
- Register programmable power management
- Dual-bit and byte wide bi-directional NRZ data interfaces
- Serial interface port for access to internal program storage registers
- Single power supply (5V \pm 10%)
- Small footprint 80-lead TQFP package

AUTOMATIC GAIN CONTROL

- Dual mode AGC, analog during acquisition, sampled during data reads
- Separate AGC level storage pins for data and servo
- Dual rate attack and decay charge pump for rapid AGC recovery
- Programmable, symmetric, charge pump currents for data reads
- Charge pump currents track programmable data rate during data reads
- Low drift AGC hold circuitry
- Low Z input switch
- AGC hold, fast recovery, and AGC input impedance control signals
- Wide bandwidth, precision full-wave rectifier

FILTER/EQUALIZER

- Programmable, 7-pole, continuous time filter provides
 - Channel filter and pulse slimming equalization for equalization to PR4
 - Programmable cutoff frequency, 3 to 24 MHz
 - Programmable boost /equalization, 0 to 13 dB
 - \pm 0.6 ns group delay variation from 0.2 f_c to f_c , with $f_c = 24$ MHz
 - Minimizes size and power
 - Low Z input switch
- Three tap self adapting transversal filter for fine equalization to PR4
- No external components required

PULSE QUALIFICATION

- Sampled Viterbi qualification of signal equalized to PR4
- Dual level pulse qualifier for servo reads

SSI 32P4903 PRML Read Channel with PR4, 8/9 ENDEC, 4-burst Servo

BLOCK DIAGRAM

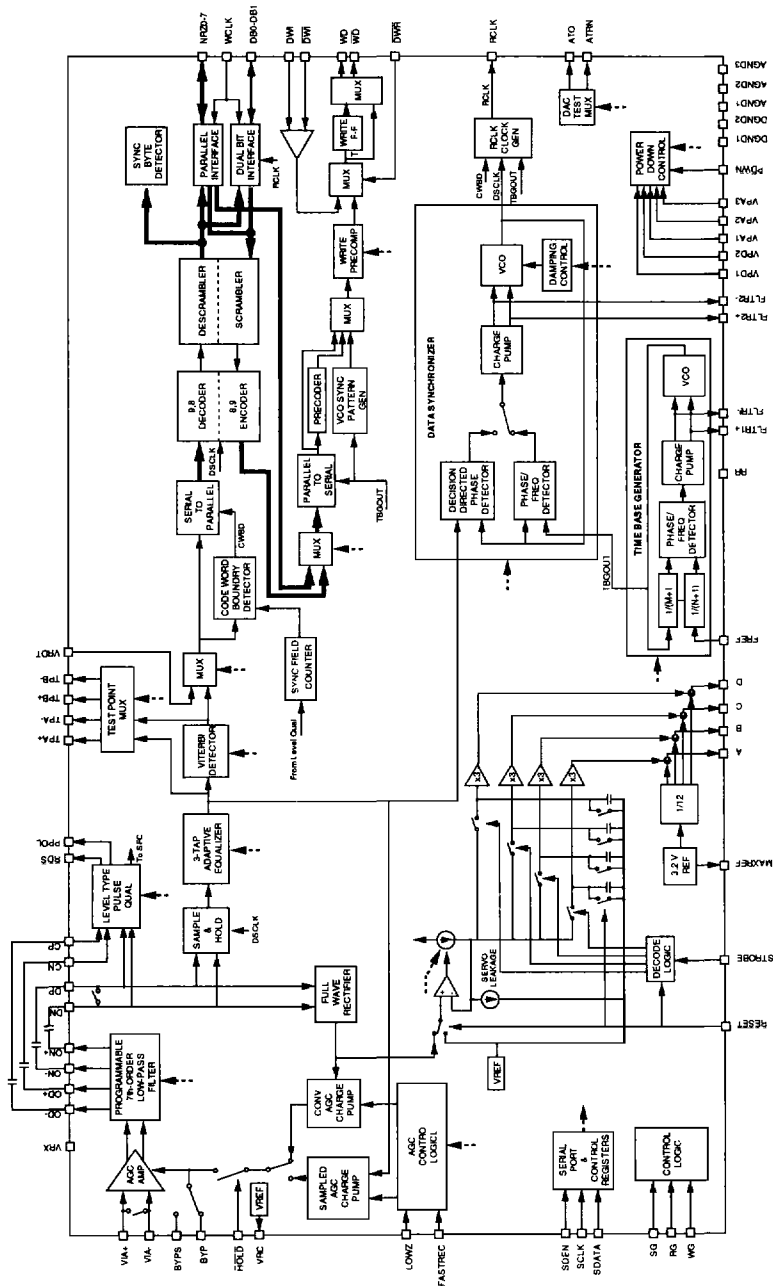

SSI 32P4903

PRML Read Channel with PR4, 8/9 ENDEC, 4-burst Servo

FEATURES (continued)

TIME BASE GENERATOR

- Less than 1% frequency resolution
- Up to 90 MHz frequency output
- Independent M and N divide-by registers
- No active external components required

DATA SEPARATOR

- Fully integrated data separator includes data synchronizer and 8,9 GCR ENDEC
- Register programmable to 80 Mbit/s operation
- Fast Acquisition, sampled data phase lock loop
- Decision directed clock recovery from data samples
- Adaptive (+) and (-) clock recovery thresholds for use with asymmetrical amplitude signals (e.g., from MR heads)
- Programmable damping ratio for data synchronizer PLL is constant for all data rates
- Data scrambler/descrambler to reduce fixed pattern effects
- Dual-bit and byte wide NRZ data interfaces
- Time base tracking, programmable write precompensation
- Differential PECL write data output
- Integrated sync byte detection

SERVO

- Four-burst servo capture with A, B, C, D outputs
- Internal hold capacitors
- "Soft Landing" charge pump architecture
- Separate, automatically selected, registers for servo f_c , boost, and threshold
- Programmable charge pump current
- Wide bandwidth, precision full-wave rectifier

FUNCTIONAL DESCRIPTION

The SSI 32P4903 implements a complete high performance PR4 read channel, including an AGC, programmable filter/equalizer, adaptive transversal filter, Viterbi pulse qualifier, time base generator, data separator with 8,9 ENDEC and scrambler/descrambler, and 4-burst servo, that supports data rates up to 80 Mbit/s.

A serial port is provided to write control data to the 16 internal program storage registers.

AGC CIRCUIT DESCRIPTION

The automatic gain control (AGC) circuit is used to maintain a constant signal amplitude at the input of the pulse detector while the input to the amplifier varies. The circuit consists of a loop that includes the AGC amplifier and charge pump, the programmable continuous time filter, and the precision wide band full wave rectifier. Depending on whether the read is of servo or data type, the specific blocks utilized in the loop are slightly different. Both loop paths are fully differential to minimize susceptibility to noise.

During servo reads the loop consists of the AGC amplifier with a continuous dual rate charge pump, the programmable continuous time filter, and the precision wide band full wave rectifier. The gain of the AGC amplifier is controlled by the voltage stored on the BYPS hold capacitor (C_{BYPS}). The dual rate charge pump drives C_{BYPS} with currents that drive the differential voltage at DP/DN to 1.27 Vp-pd. Attack currents lower the V_{BYPS} which reduces the amplifier gain. The dual rate attack charge pump is included for fast transient recovery. The normal AGC attack current in servo mode is 141 μ A. When the signal exceeds 125% of the nominal signal level, the attack current is increased by a factor of 8.4. The nominal decay current is 8.3 μ A, and increases by a factor of 8 when the FASTREC input is high. In this mode, transients that produce low gain will recover more rapidly with the Fast Decay current, while transients that produce high gain will put the circuit in the fast attack recovery mode.

SSI 32P4903

PRML Read Channel with PR4, 8/9 ENDEC, 4-burst Servo

AGC CIRCUIT DESCRIPTION *(continued)*

For data reads, the loop described above is used until the data synchronizer is locked to the incoming VCO preamble, except that to optimize recovery for constant density recording, both of the AGC charge pumps' currents track the data rate value loaded in the Data Rate Register and that the BYP hold capacitor (CBYP) is now used. In addition, at the maximum data rate, the nominal AGC attack current is 391 μA and the nominal decay current is 23 μA . The fast attack and fast decay current factors are the same as in servo mode. After this point, the loop is switched to include the AGC amplifier with a sampled dual rate charge pump, the programmable continuous time filter, full wave rectifier, and the sampling 3-tap adaptive equalizer to more accurately control the signal amplitude into the Viterbi qualifier. In this sampled AGC mode, a symmetrical attack and decay charge pump is used. The "1" sample amplitudes are sampled and held and compared to a threshold to generate the error current. The maximum charge pump current value can be programmed from the Sample Loop Control Register to 0, 23, 46, or 69 μA .

For maximum application flexibility, all AGC mode control inputs are designed to be externally controlled. When the LOWZ input is high, Low-Z mode is activated. In the Low-Z mode, the AGC amplifier input impedance is reduced to allow quick recovery of the AGC amplifier input ac coupling capacitors. This mode should be activated during and for a short time after a write operation.

When the $\overline{\text{HOLD}}$ input is low, the dual rate attack charge pumps are disabled. This de-activates the AGC loop. The AGC amplifier gain will be held constant at a level set by the voltage at the BYP or BYPS pins.

In most applications, the BYP and BYPS pin voltages are stored on external capacitors. In applications where AGC action is not desired, the BYP and BYPS voltages can be set by resistor divider networks connected from VPA to VRC. If programmable gain is desired, the resistor network could be driven by a current DAC.

PULSE QUALIFICATION CIRCUIT DESCRIPTIONS

This device utilizes two different types of pulse qualification, one primarily for servo reads and the other for data reads.

Dual Level Qualifier

During servo reads (SG high) a dual level type of pulse qualifier is used. The level qualification thresholds are set by a 7-bit DAC which is controlled by the Servo Level Threshold Register. The register value is relative to the peak voltage at the output of the continuous time filter, and the DAC is referenced to a fixed internal reference voltage. The positive and negative thresholds are equal in magnitude. The state of the adaptive threshold level enable (ALE) bit in the WP/LT Register does not affect this DAC's reference. The $\overline{\text{RDS}}$ and the PPOL outputs of the level qualifier indicate a qualified servo pulse and the polarity of the pulse, respectively.

In data read mode (RG high), the same dual level qualifier as was used for servo reads, is used for ensuring pulse polarity changes during VCO sync field counting. Its qualification thresholds are set by a 7-bit DAC which is controlled by the Data Level Threshold Register. Prior to SFC, the DAC is referenced to a fixed internal reference voltage. After SFC, the register value is relative to the peak voltage at the output of the equalizer. The positive and negative thresholds are equal in magnitude. The state of the adaptive threshold level enable (ALE) bit in the WP/LT Register does not affect the DAC's reference until the sync field count has been achieved. The $\overline{\text{RDS}}$ and the PPOL outputs of the level qualifier are not active in data read mode.

SSI 32P4903

PRML Read Channel with PR4, 8/9 ENDEC, 4-burst Servo

Viterbi Qualifier

The second type of pulse qualification, the Viterbi qualifier, is only used during data read mode after the sync field count has been achieved. The Viterbi qualifier has two significant blocks, one that feeds the other. The first block is the sampled pulse detector and the second is the survival sequence register.

The sampled pulse detector performs the pulse acquisition/detection in the sampled domain. It acquires pulses by comparing the code clock sampled level of the analog waveform to the positive and negative thresholds established by the programmable Viterbi threshold window. The Viterbi threshold window is defined to be the difference between the positive and negative threshold levels. The threshold window, V_{th} , is set by a 7-bit DAC which is controlled by the Viterbi Detector Control Register. While the window size is fixed by the programmed V_{th} value, the actual positive and negative thresholds track the most positive and the most negative samples of the equalized input signal. For example, the Viterbi positive signal threshold, $V_{pt} = V_{peak(+)} \max$ if the previous detected level was (+). If the previous detect level was (-), $V_{pt} = V_{peak(-)} \max + V_{th}$, where $V_{peak(-)} \max$ is the maximum amplitude of the previously detected negative signal. Normally V_{th} is set to equal V_{peak} (approx. 500 mV).

After the pulses have been detected they must be further qualified by the survival sequence registers and associated logic. This logic guarantees that for sequential pulses of the same polarity within the maximum run length, only the latest is qualified. By definition, this is the pulse of greatest amplitude.

The Viterbi qualifier is implemented as two parallel qualifiers that operate on interleaved samples. Each qualifier has a survival sequence register length of 5.

PROGRAMMABLE FILTER CIRCUIT DESCRIPTION

The on-chip, continuous time, low pass filter has register programmable cutoff and boost settings, and provides both normal and differentiated outputs. It is a 7th order filter that provides a 0.05° phase equiripple response. The group delay is relatively constant up to 1.75 times the cutoff frequency. For pulse slimming two zero programmable boost equalization is provided with no degradation to the group delay performance. The differentiated output is created by a single-pole, single-zero differentiator. Both the boost and the filter cutoff frequency are programmed through internal 7-bit DACs, accessed via the serial port logic. The nominal boost range at the cutoff frequency is 0 to 12.75 dB at maximum f_c and is controlled by the Data Boost Register or the Servo Boost Register in the servo mode. The cutoff frequency, f_c is variable from 3 to 24 MHz and controlled by the Data Cutoff Register or Servo Cutoff Register in the servo mode. The cutoff and boost values for servo reads are automatically switched when servo mode is entered.

The current reference for the filter DACs is set using a single 12.1 k Ω resistor, from the VRX pin to ground. The voltage at VRX is proportional-to-absolute-temperature (PTAT).

ADAPTIVE EQUALIZER CIRCUIT DESCRIPTION

Up to 7 dB of cosine equalization for fine shaping of the incoming read signal to the PR4 waveshape is provided by a 3-tap, sampled analog, transversal filter with an adaptive multiplier coefficient. The same multiplier coefficient (k_m) is used for both of the outside taps. The value of k_m is adjusted to force "zero" samples to zero volts. A special equalizer training pattern, located after the VCO sync field in the sector format, is used to provide an optimum signal for the equalizer to adapt to. The adaptive property of the equalizer is enabled or disabled by the AEE bit in the Sample Loop Register. If the adaptive property is enabled, whether adaptation occurs only during the training pattern or both during the training pattern and the user data is controlled by the AED bit in the Sample Loop Register.

SSI 32P4903

PRML Read Channel with PR4, 8/9 ENDEC, 4-burst Servo

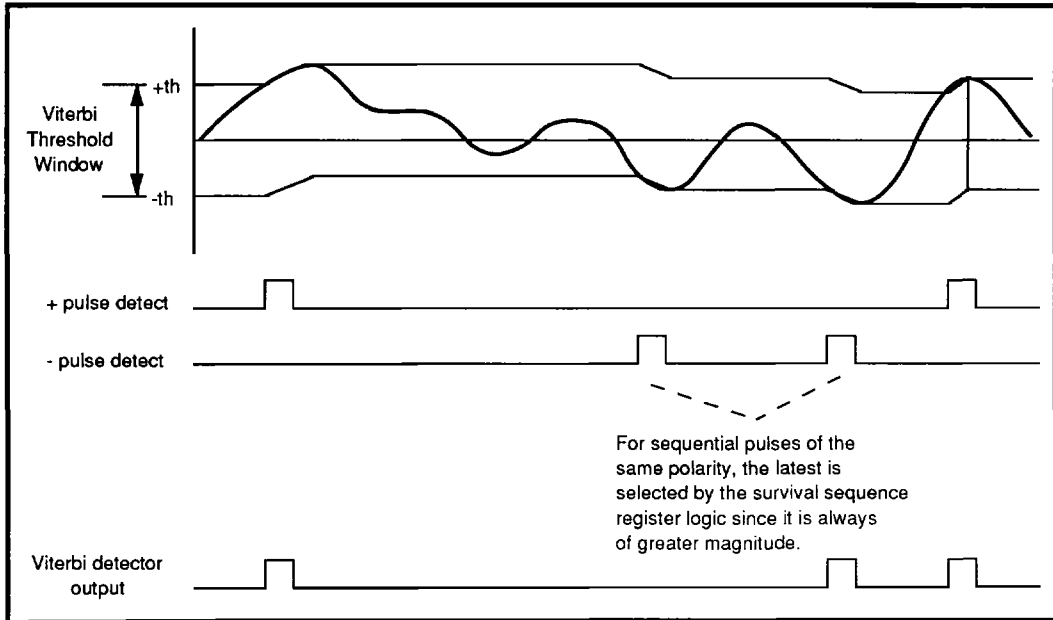

FIGURE 1: Viterbi Detection

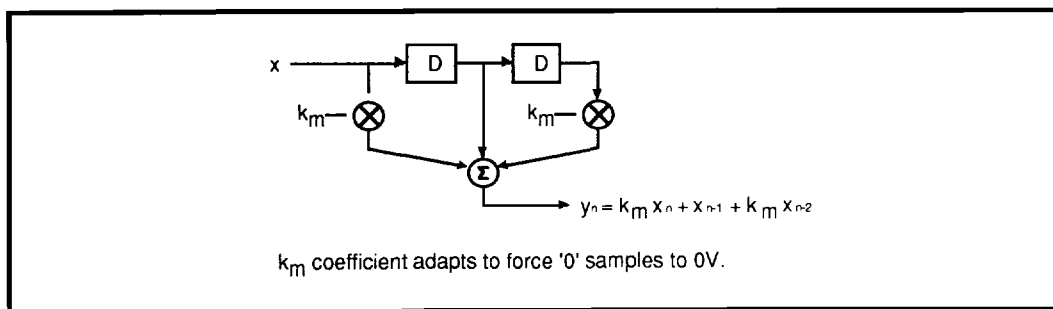

FIGURE 2: Block Diagram of 3-Tap Adaptive Equalizer

SSI 32P4903

PRML Read Channel with PR4, 8/9 ENDEC, 4-burst Servo

FUNCTIONAL DESCRIPTION (continued)

TIME BASE GENERATOR CIRCUIT DESCRIPTION

The time base generator (TBG) is a PLL based circuit, that provides a programmable reference frequency to the data separator for constant density recording applications. This time base generator output frequency can be programmed with a better than 1% accuracy via the M, N and DR Registers. The TBG output frequency, F_{out} , should be programmed as close as possible to $((9/8) \cdot \text{NRZ Data Rate})$. The time base also supplies the timing reference for write precompensation so that the precompensation tracks the reference time base period.

The time base generator requires an external passive loop filter to control its PLL locking characteristics. This filter is fully-differential and balanced in order to reduce the effects of common mode noise.

In servo read, write and idle modes, the programmable time base generator is used to provide a stable reference frequency for the data separator. In the write and idle modes, the Time Base Generator output, when selected by the Control Test Mode Register, can be monitored at the TPA+ and TPA- test pins. In the read mode, the TBG output should not be selected for output on the test pins so that the possibility of jitter in the data separator PLL is minimized.

The reference frequency is programmed using the M and N registers of the time base generator via the serial port, and is related to the external reference clock input, FREF, as follows:

$$FTBG = FREF [(M + 1) + (N + 1)]$$

The M and N values should be chosen with the consideration of phase detector update rate and the external passive loop filter design. The Data Rate Register must be set to the correct VCO center frequency. The time base generator PLL responds to any changes to the M and N registers, only after the DR register is updated.

The DR register value, directly affects the following:

- center frequency of the time base generator VCO
- center frequency of the data separator VCO
- phase detector gain of the time base generator phase detector
- phase detector gain of the data separator phase detector
- write precompensation

The reference current for the DR DAC is set by an external resistor, RR, connected between the ground and RR pins.

$$RR = 12.1 \text{ k}\Omega$$

DATA SEPARATOR CIRCUIT DESCRIPTION

The Data Separator circuit provides complete encoding, decoding, and synchronization for 8,9 (0,4,4) GCR data. In data read mode, the circuit performs clock recovery, code word synchronization, decoding, sync byte detection, descrambling, and NRZ interface conversion. In the write mode, the circuit generates the VCO sync field, scrambles and converts the NRZ data into 8,9 (0,4,4) GCR format, precodes the data, and performs write precompensation.

The circuit consists of five major functional blocks; the data synchronizer, 8,9 ENDEC, NRZ scrambler/descrambler, NRZ interface, and write precompensation.

Data Synchronizer

The data synchronizer uses a fully integrated, fast acquisition, PLL to recover the code rate clock from the incoming read data. To achieve fast acquisition, the data synchronizer PLL uses two separate phase detectors to drive the loop. A decision-directed phase detector is used in the read mode and phase-frequency detector is used in the idle, servo, and write modes.

SSI 32P4903

PRML Read Channel with PR4, 8/9 ENDEC, 4-burst Servo

Data Synchronizer (continued)

In the read mode the decision-directed timing recovery updates the PLL by comparing amplitudes of adjacent "one" samples or comparing the "zero" sample magnitude to ground for the entire sample period. A special (non-IBM) algorithm is used to prevent "hang up" during the acquisition phase. The determination of whether a sample is a "one" or a "zero" is performed by a dedicated, dual mode, threshold comparator. This comparator's threshold levels are determined by the value, Lth, programmed in the Data Threshold Register. The fixed level threshold before the sync field count (SFC) has been achieved will be 1.27 times the threshold level after SFC since this is the ratio of the peak signal to the sampled "1" signal amplitude for PR4. The dual mode nature of this comparator allows the selection of either symmetric fixed or independent self adapting (+) and (-) thresholds by programming the adaptive level enable (ALE) bit in the WP/LT Register.

The adaptive reference allows the specification of the threshold value to be a percentage of an averaged peak value. When adaptive mode is selected, the fixed thresholds are used until the sync field count (SFC) has been reached, then the adaptive levels are internally enabled. The time constant of a single pole filter that controls the rate of adaptation, is programmable by bits TC3-1 in the WP/LT Register.

In the write and idle modes the non-harmonic phase-frequency detector is continuously enabled, thus maintaining both phase and frequency lock to the time base generator's VCO output signal, FTBG. The polarity and width of the detector's output current pulses correspond to the direction and magnitude of the phase error.

The two phase detectors' outputs are muxed into a single differential charge pump which drives the loop filter directly. The loop filter requires an external capacitor. The loop damping ratio is programmed by bits 6-0 in the Damping Ratio Control Register. The programmed damping ratio is independent of data rate.

In write mode, the TBG output is used to clock the encoder, precoder, and write precompensation circuits. The output of the precompensation circuit is then fed to the write data flip-flop which generates the write data (WD, \overline{WD}) outputs.

ENDEC

The ENDEC implements an 8,9 (0,4,4) Group Coded Recording (GCR) algorithm. The code has a minimum of no zeros between ones and a maximum of four zeros between ones for the interleaved samples. During write operations the encoder portion of the ENDEC converts 8-bit parallel, scrambled or nonscrambled, data to 9-bit parallel code words that are then converted to serial format. In data read operation, after the code word boundary has been detected in the Viterbi qualified serial data stream, the data is converted to 9-bit parallel form and the decoder portion of the ENDEC converts the 9-bit code words to 8-bit NRZ format.

Scrambler/Descrambler

The scrambler/descrambler circuit is provided to reduce fixed pattern effects on the channel's performance. It is enabled or disabled by bit 2 of the Control Operating Register. In write mode, if enabled, the circuit scrambles the 8-bit internal NRZ data before passing it to the encoder. Only user data, i.e., the NRZ data following the sync byte, is scrambled. In data read mode, only the decoded NRZ data after the sync byte is descrambled. The scrambler polynomial is $H(X) = 1 \oplus X^7 \oplus X^{10}$.

NRZ Interface

The NRZ interface circuit provides the ability to interface with either a dual bit or byte wide controller. The NRZ interface type is specified by the programming of bit 4 of the Control Operating Register. If byte wide mode is selected, the circuit does not reformat the data before passing it to and from the internal 8-bit bus. If dual bit mode is selected, the NRZ interface circuit converts the external dual bit bus to the internal 8-bit bus. Only the selected NRZ interface is enabled and the other can be left floating. Both the byte wide and dual bit interfaces define the most significant bit of the interface as the most significant bit of the data and the dual bit interface defines the first pair clocked in or out as the most significant pair.

For both byte wide and dual bit operation, the NRZ write data is latched by the 32P4903 on the rising edge of the WCLK input. The WCLK frequency must be appropriate for the data rate chosen or else overflow/underflow will occur. It is recommended that WCLK be connected to RCLK to prevent this from occurring.

SSI 32P4903 PRML Read Channel with PR4, 8/9 ENDEC, 4-burst Servo

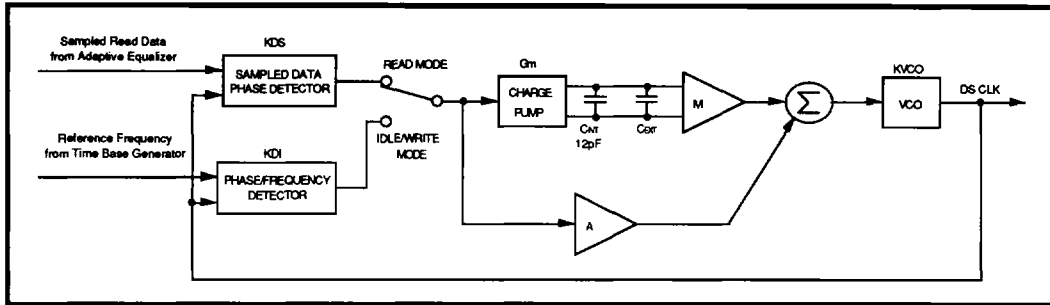

FIGURE 3: Data Synchronizer Phase Locked Loop

4

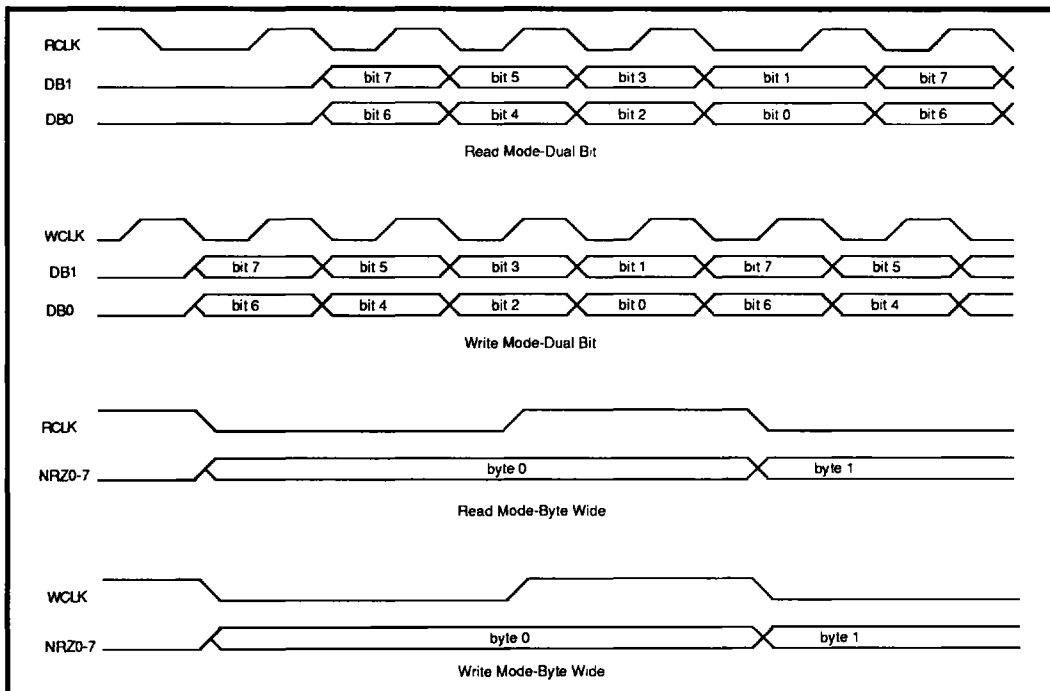

FIGURE 4: RCLK, WCLK vs. NRZ Data

SSI 32P4903

PRML Read Channel with PR4, 8/9 ENDEC, 4-burst Servo

NRZ Interface (continued)

In data read mode, the NRZ data will be presented to the controller near the falling edge of RCLK so that it can be latched by the controller on the rising edge of RCLK. When RG goes high, the selected NRZ interface will output low data until the sync byte has been detected. The first non-zero data presented will be the sync byte (96H). The NRZ interface is at a high impedance state when not in data read mode. In byte-wide mode, an even parity bit, NRZP, is generated for each output byte.

Write Precompensation

The write precompensation circuitry is provided to compensate for media bit shift caused by magnetic nonlinearities. The circuit recognizes specific write data patterns and can add delays in the time position of write data bits to counteract the magnetic nonlinearity effect. The magnitude of the time shift, WPC, is programmable via the Write Precomp Register and is made proportional to the time base generator's VCO period (i.e., data rate). The circuit performs write precompensation only on the second of two consecutive "ones" and only shifts in the late direction. If more than two consecutive "ones" are written, all but the first are precompensated in the late direction.

SERVO DEMODULATOR CIRCUIT DESCRIPTION

Servo functionality is provided by two separate circuits: the servo demodulator circuit, and the previously described dual level pulse qualifier circuit. To support embedded servo applications, 32P4903 provides a separate programmable registers for servo mode filter cutoff frequency, boost, and qualification threshold. The values programmed in these registers are selected upon entry into servo mode (SG = 1).

The servo demodulator circuit captures four separate servo bursts and provides an amplified and offset version of the voltages captured for each at the A, B, C, and D output pins respectively. The circuit uses a "Soft Landing" charge pump with programmable initial charge current to charge each of the internal 10 pF burst hold capacitors. The "Soft Landing" charge pump architecture prevents the hold capacitor from being charged to a voltage greater than the actual instantaneous peak voltage at the full wave rectifier output. Internal burst hold capacitors are provided to support low leakage burst capture and to reduce external component count. Burst capture control is

provided by the STROBE and $\overline{\text{RESET}}$ input pins. In addition to the A, B, C, and D outputs pins, the circuit provides a maximum reference voltage at the MAXREF output pin. This reference voltage represents the maximum voltage that can be achieved at the A, B, C, and D output pins and is typically used as the reference voltage for an external A/D converter.

BURST CAPTURE

Burst capture is controlled by the signal applied to the STROBE input pin and an internal counter. The first pulse on the STROBE input pin causes the A burst hold capacitor to be charged by the charge pump. The capacitor charges for as long as the STROBE input is high or until the capacitor voltage reaches the peak voltage at the full wave rectifier output. On the falling edge of the STROBE signal, the internal counter is incremented. The next 3 STROBE pulses will charge the B, C, and D, hold capacitors respectively. After the falling edge of the fourth strobe, the counter is reset to zero and the burst capture can be repeated. The counter is also reset when the $\overline{\text{RESET}}$ input transitions low.

The voltage level on each hold capacitor is amplified by a factor of 3 and summed with a 0.27V DC reference to create the A, B, C, and D output signals. A 1.27 Vp-p differential voltage at the DP/DN pins will result in $1.27 \times 0.75 \times 3 = 2.86\text{V}$ peak burst amplitude (i.e., servo gain = 2.25). The MAXREF output pin is a nominal 3.2V and is internally divided by 12 to create the DC baseline of 0.27V.

All four of the internal hold capacitors are discharged when the $\overline{\text{RESET}}$ input is driven low. The $\overline{\text{RESET}}$ input overrides the STROBE signal. STROBE and $\overline{\text{RESET}}$ are not gated with SG.

The maximum charge pump current can be selected as 100 μA or 160 μA by setting the servo burst charge current (SBCC) bit in the Sample Loop Control Register to 0 or 1, respectively. The "Soft Landing" technique reduces the charge pump current as the error between the voltage on the hold capacitor and the full wave rectifier output becomes smaller. This reduces the possibility of overcharging the capacitor during the comparator's propagation delay period.

A small leakage current is applied to the capacitor being charged during each strobe period to make the captured voltage less sensitive to noise and strobe timing. The magnitude of this current is 1/400 of the charge current.

SSI 32P4903
PRML Read Channel with
PR4, 8/9 ENDEC, 4-burst Servo

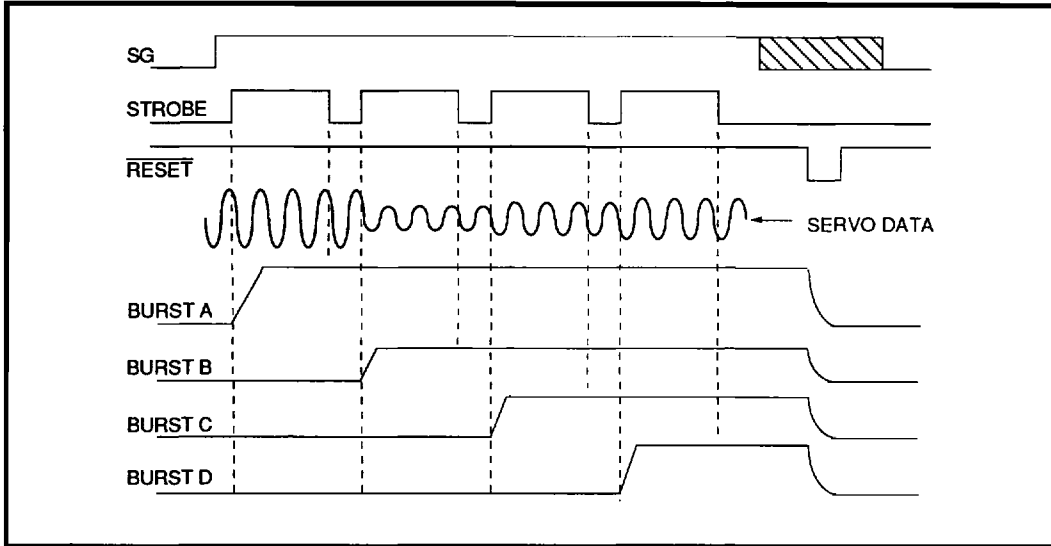

FIGURE 5: Servo Capture Timing Diagram

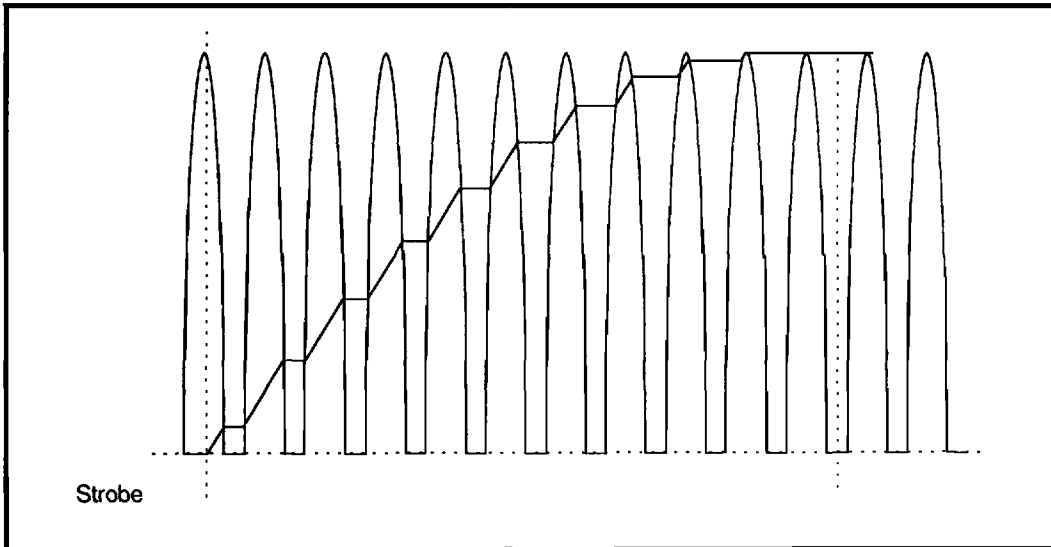

FIGURE 6: Servo Burst Acquisition ($SG = \overline{RESET} = 1$)

4

SSI 32P4903

PRML Read Channel with PR4, 8/9 ENDEC, 4-burst Servo

SERVO DEMODULATOR CIRCUIT

DESCRIPTION (continued)

Timing Outputs

The dual level qualifier that was previously described is used to generate the \overline{RDS} and PPOL timing signals. The \overline{RDS} output pin pulses low for each positive or negative servo peak that is qualified by the dual level qualifier. The PPOL output pin provides the pulse polarity information for the qualified peaks, where PPOL=1 for a positive peak and PPOL=0 for a negative peak. To reduce noise propagation, the \overline{RDS} and PPOL outputs are only active in servo mode.

SERIAL PORT CIRCUIT DESCRIPTION

The serial port interface is used to program the 32P4903's sixteen internal registers. The serial port is enabled for data transfer when the Serial Data Enable (SDEN) pin is high ("1"). SDEN must be asserted high prior to any transmission and it should remain high

until the completion of the transfer. At the end of each transfer SDEN should be brought low ("0").

When SDEN is high, the data presented to the Serial Data (SDATA) pin will be latched into the 32P4903 on each rising edge of the Serial Clock (SCLK). Rising edges of SCLK should only occur when the desired bit of address or data is being presented on the serial data line. Serial data transmissions must occur in 16-bit packets. The data is latched into the internal register on the falling edge of SDEN.

Each 16-bit transmission consists of a R/W bit (R/W="0") followed by 3 device select bits, 4 address bits and eight data bits. The address bits select the internal register to be written to. The device select, address and data fields are input LSB first, MSB last, where LSB is defined as Bit 0. The three device select bits select the device on the SSI serial bus to be communicated with and must be set S0 = 0, S1 = 1, and S2 = 0 when communicating with the 32P4903. Figure 8 shows the serial interface timing diagram.

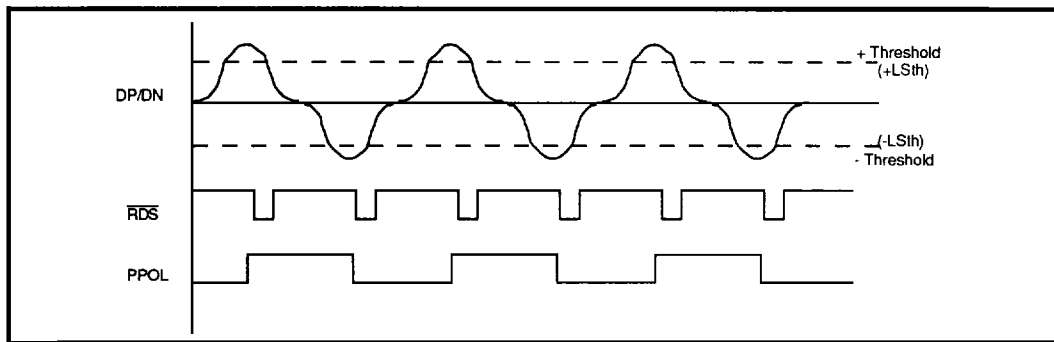

FIGURE 7: \overline{RDS} and PPOL vs. DP/DN Relationship

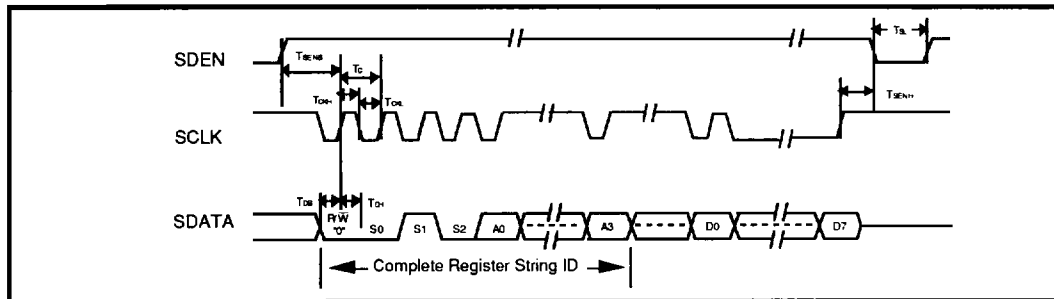

FIGURE 8: Serial Interface Timing

SSI 32P4903

PRML Read Channel with PR4, 8/9 ENDEC, 4-burst Servo

OPERATING MODES

The fundamental operating modes of the 32P4903 are controlled by the SERVO GATE (SG), READ GATE (RG), and WRITE GATE (WG) input pins. The exclusive assertion of any these inputs causes the device to enter that mode. If none of these inputs is asserted, the device is in the IDLE mode. If more than one of the inputs is asserted, the mode is determined by the following hierarchy: SG overrides RG which overrides WG. The mode that is overriding takes effect immediately.

RG and SG are asynchronous inputs and may be initiated or terminated at any position on the disk. WG is also an asynchronous input, but should not be terminated prior to the last output write data (WD/ \overline{WD}) pulse.

IDLE MODE OPERATION

If SG, RG, and WG are not active, the 32P4903 is in idle mode. When in idle mode, the Time Base Generator and the Data Separator PLL are running and the Data Separator PLL is phase-frequency locked to the TBG VCO output. The AGC, continuous time filter, and pulse qualifiers are active but the outputs of the pulse qualifiers are disabled. The continuous time filter is using its programmed values for cutoff frequency and boost determined by the data mode registers. The AGC operation is the same as in the VCO preamble portion of a data read.

SERVO MODE OPERATION

If SG is high, the device is in the servo mode. This mode is the same as idle except that the filter cutoff and boost settings are switched from those programmed for data read mode to those programmed for servo mode, the AGC is switched to servo mode, the dual level qualifier's threshold is switched to the programmed servo threshold, and the \overline{RDS} and PPOL outputs are enabled. The assertion of SG causes read mode and write mode to be overridden.

WRITE MODE OPERATION

The 32P4903 supports three different write modes: Normal write mode, direct write mode #1 and direct write mode #2. The direct write modes require that either the direct write bit, bit 0 of the Control Operating Register, or the \overline{DWR} pin be active. All three write modes require that the data separator be powered on.

Normal Write Mode

The 32P4903 is in the normal write mode if WG is high, \overline{DWR} is high, and the direct write bit in the Control Operating Register is low (Bit 1 of the Power Down Register must be set to 0). A minimum of one NRZ time period must elapse after RG goes low before WG can be set high. The data separator PLL is phase-frequency locked to the TBG VCO output in this mode.

In normal write mode, the circuit first auto generates the VCO sync pattern, and then scrambles the incoming NRZ data from the controller, encodes it into 8,9 GCR formatted data, precodes it, precompensates it, feeds it to a write data toggle flip-flop, and outputs it to the preamp for storage on the disk. The write data flip-flop is reset when WG goes low to ease testing. The circuit can operate in either soft or hard sector modes.

When the write gate (WG) goes high, the circuit begins to generate the VCO sync field. The VCO sync field equals a $2T$ $\{(1,1,-1,-1,1,1,-1,-1,\dots)\}$ in the write current domain at the WD/ \overline{WD} outputs. While the preamble is being written, WCLK must continue to clock in all "0" NRZ data. After the required sync field has been written (approx. 8 byte times, min.), the NRZ data must be changed to 93H for a minimum of 5 byte times to write the minimum 5 byte equalizer training pattern. The device will continue to autogenerate the sync field pattern until the first 93H is latched at the NRZ interface, and detected. The device encodes the 93H pattern and writes the result as the training sequence. Next, the NRZ data must be changed to 96H for 1 byte time to write the sync byte. The user data must be presented at the NRZ interface immediately following the sync byte. Finally, after the last byte of user data has been clocked in, the WG must remain high for a minimum of 34 NRZ bit times in byte-wide mode to ensure that the device is flushed of data (The delay is 37 NRZ bit times in dual bit mode). WG can then go low. WD/ \overline{WD} stops toggling a maximum of 2 NRZ (RCLK) time periods after WG goes low.

SSI 32P4903

PRML Read Channel with PR4, 8/9 ENDEC, 4-burst Servo

WRITE MODE OPERATION (continued)

Direct Write Mode #1

In this direct write mode, the NRZ data from the byte-wide interface bypasses the scrambler, the 8,9 encoder and the precoder, but is precompensated before going to the write data flip-flop and then to the WD/ \overline{WD} output pins. The precomp should be set to zero in this mode. The purpose of routing the signal to the precomp circuit is to generate a return to zero pulse every time a "1" occurs in the data so that the write data flip-flop is toggled. WCLK is required to clock the byte-wide NRZ data into the NRZ interface. Direct write mode #1 is entered simply by setting the DW bit (bit 0) in the Control Operating Register. This mode is not valid when using the dual-bit NRZ interface.

Direct Write Mode #2

In this direct write mode, the data presented at the DW/ \overline{DW} input pins directly toggles the write data flip-flop which drives the WD/ \overline{WD} output pins. No WCLK is required in this mode, and the WD/ \overline{WD} output is not resynchronized. Direct write mode #2 is entered simply by driving the \overline{DWR} input low.

DATA READ MODE OPERATION

Data read mode is initiated by setting the Read Gate (RG) input pin high. This action causes the data synchronizer to begin acquisition of the clock from the incoming VCO sync pattern. To achieve this, the data synchronizer utilizes a fully integrated fast acquisition PLL to accurately develop the sample clock. This PLL is normally locked to the time base generator output, but when the Read Gate input (RG) goes high, the PLL's reference input is switched to the filtered incoming read signal.

Acquisition of DS VCO Sync

Asserting Read Gate (RG=high) initiates the read sequence. This causes an internal counter to begin counting the pulses that are qualified by the dual level pulse qualifier given the polarity changes of the incoming 1,1,-1,-1,1,1 read back pattern defined by the VCO sync field. When the count reaches 4, the internal read gate is asserted and the DS PLL input is switched from the TBG's VCO output to the sampled data input. This is also the point at which the DS PLL's phase detector is switched from the phase-frequency

detector to the decision directed phase detector. The counter is also used to determine whether the selected sync field count, SFC, has been achieved. When the counter reaches the value specified by SFC, the data synchronizer PLL is assumed to be locked and settled (VCO lock). Also at SFC, the phase detector gain switch and the AGC mode switch occur. To allow for different preamble lengths, the SFC can be set to 64, 80, 96 or 128 from the Sample Loop Control Register. These values for the SFC may be thought of as the number of code clock periods in the sync field, but they actually represent twice the number of incoming polarity changes required.

VCO Lock, PD Gain, AGC Mode Switch, and Code Word Boundary Detector Enable

At SFC, one of two phase tracking methods will be chosen depending on the Enable Phase Detector Gain Switching (GS) bit in the Control Operating Mode Register. When the GS bit is high, the phase detector gain is reduced by a factor of 5 after the SFC count is reached. When the GS bit is low, no phase detector gain switching takes place.

Also after SFC, the AGC feedback will be switched from the continuous time fullwave rectifier to sampled data feedback.

At SFC, the internal VCO lock signal activates the code word boundary detection circuitry to define the proper decode boundaries. Also, at count SFC, the RCLK generator source switches from the TBG's VCO output to the DS VCO clock signal which is phase locked to the incoming read data samples. The DS VCO is assumed locked to the incoming read samples at this point. A maximum of 1 RCLK time period may occur for the RCLK transition, however, no short duration glitches will occur. After the code word detection circuitry finds the proper code word boundary, the RCLK generator is resynchronized to guarantee that the RCLK is in sync with the data. The RCLK output will not glitch and will not toggle during the RCLK generator resynchronization for up to 2 byte times maximum.

Also at the code word boundary detect, the internal 9-bit code words are allowed to pass to the ENDEC for decoding. This decoding will occur until read gate is deasserted.

SSI 32P4903

PRML Read Channel with PR4, 8/9 ENDEC, 4-burst Servo

ADAPTIVE EQUALIZER TRAINING SEQUENCE

As was previously discussed, in a normal write sequence, a minimum of 5 bytes of NRZ 93H and one byte of 96H must be written between the end of the VCO sync field and the beginning of the user data. The 5 bytes of 93H are 8,9 encoded and precoded during write mode to produce the adaptive equalizer training pattern. During read mode, this sequence (100110011 read data sequence) is used to adaptively train the three tap transversal filter in a zero forcing manner. The error at the filter output is integrated to derive the tap weight multiplying coefficient, Km. The filter input and output taps will have the same Km. It is anticipated that the continuous time filter will be used for coarse equalization and that transversal filter will be used adaptively for fine tuning. This will reduce Km's range and accuracy requirements. Since there are

encoded user data patterns that will not produce an equalizer correction error, an equalization hold during data mode can be selected from the Sample Loop Control Register. After the training pattern, if the loop is active during data, the equalizer loop gain will be reduced by 3. The loop's integration time constant is made inversely proportional to the selected data rate.

NRZ Output

As the read data is 8,9 decoded, it is compared to an internally fixed sync byte (96H). When a match is found the NRZ output data that until now was held low, is changed to 96H. The next byte presented on the NRZ outputs is the first byte of user data. When the read gate is deasserted the NRZ outputs go to a high impedance state.

4

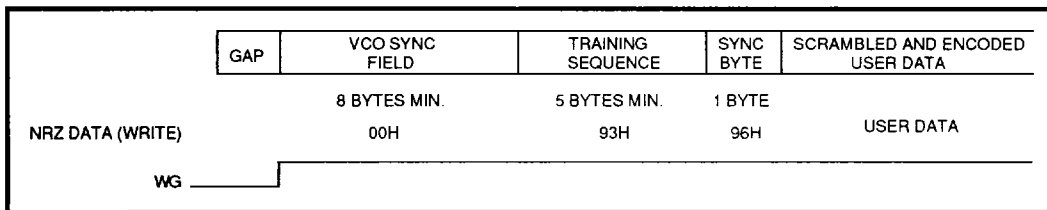

FIGURE 9: Sector Write Sequence

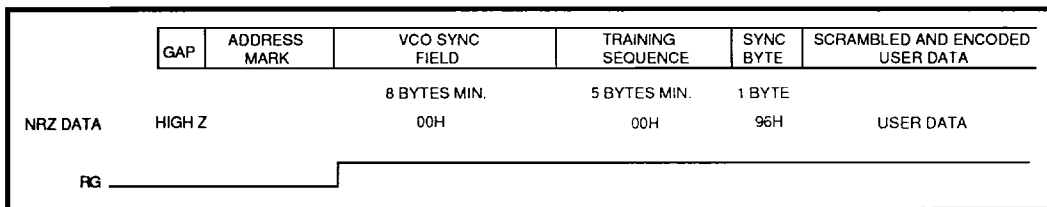

FIGURE 10: Sector Read Sequence

SSI 32P4903

PRML Read Channel with PR4, 8/9 ENDEC, 4-burst Servo

OPERATING MODES (continued)

POWER DOWN OPERATION

The power management modes of the 32P4903 are determined by the states of the Power Down Register bits and the $\overline{\text{PDWN}}$ and SG inputs. The individual sections of the chip can be powered down or up using the Power Down Register. A high level in a Power Down Register bit disables that section of the circuit. The power down information from the Power Down Register takes effect immediately after the SDEN pin goes low.

When the $\overline{\text{PDWN}}$ input is low, the chip goes into full power down mode regardless of the power down register settings or the state of the SG input.

When $\overline{\text{PDWN}}$ is high, SG will force the AGC, filter, and pulse qualifier circuits (front end) to be active by overriding the front end register bit. The back end power down register bits, which include the Data Separator and Time Base Generator are not affected by the SG input.

The serial port is active in all power down modes.

The time to restart from a full power down is dependent on the PLL loop filter and the data rate.

The truth table for the various modes of operation is shown below:

SG, $\overline{\text{PDWN}}$	1,1	1,0	0,1	0,0
Front End	ON	OFF	R	OFF
Data Separator	R	OFF	R	OFF
Time Base Generator	R	OFF	R	OFF
Serial Port	ON	ON	ON	ON

R = Controlled by register bit.
(Register bit = 1 turns circuits OFF,
Register bit = 0 turns circuits ON)

SSI 32P4903
PRML Read Channel with
PR4, 8/9 ENDEC, 4-burst Servo

SERIAL PORT REGISTER DEFINITIONS

Complete Register String ID	A3	A2	A1	A0	S2	S1	S0	R/W	
Power Down Register	0	0	0	0	0	1	0	0	04H
	Bits 7	ATO	Bit set to 1 enables ATO. Set bit to 0 for normal operation						
	Bit 6	WDT	Write data test mode. Bit set to 1 enables test mode that initializes precoder to 0. Bit set to 0 in normal operation						
	Bit 5-3	X	Factory reserved bit. Must set to 0 in application						
	Bit 2	TB	Time Base Generator power down when bit set to 1						
	Bit 1	DS	Data Separator power down when bit set to 1						
Data Filter Cutoff Register	0	0	0	1	0	1	0	0	14H
	Bit 7	X	Factory reserved bit for oscillator trim, must be set to 0 in application						
	Bits 6-0	FC6-0	Filter cutoff frequency setting in non-servo mode $f_c \text{ (MHz)} = 0.1955 \cdot FC - 0.8285$ $20 \leq FC \leq 127_{DEC}$						
Servo Filter Cutoff Register	0	0	1	0	0	1	0	0	24H
	Bit 7	X	Factory reserved bit. Must set to 0 in application						
	Bits 6-0	FCS6-0	Filter cutoff frequency setting in servo mode $f_c \text{ (MHz)} = 0.1955 \cdot FCS - 0.8285$ $20 \leq FCS \leq 127_{DEC}$						
Data Filter Boost Register	0	0	1	1	0	1	0	0	34H
	Bit 7	X	Factory reserved bit. Must set to 0 in application						
	Bits 6-0	FB6-0	Filter boost setting in servo mode $\text{Boost (dB)} = 20 \cdot \log [0.0208 \cdot FB + 0.000045 \cdot FB \cdot FC - 0.000012 \cdot FB^2 + 1]$ $0 \leq FB \leq 127_{DEC}$						
Servo Filter Boost Register	0	1	0	0	0	1	0	0	44H
	Bit 7	X	Factory reserved bit. Must set to 0 in application						
	Bits 6-0	FBS6-0	Filter boost setting in servo mode $\text{Boost (dB)} = 20 \cdot \log [0.0208 \cdot FBS + 0.000045 \cdot FBS \cdot FCS - 0.000012 \cdot FBS^2 + 1]$ $0 \leq FBS \leq 127_{DEC}$						
Viterbi Detector Threshold Register	0	1	0	1	0	1	0	0	54H
	Bit 7	X	Factory reserved bit. Must set to 0 in application						
	Bits 6-0	VD6-0	Viterbi qualification threshold voltage $V_{TH} \text{ (mV)} = 9.94 \cdot VD - 175$ $45 \leq VD \leq 127_{DEC}$						

1 = power down; 0 = power up

4

SSI 32P4903
PRML Read Channel with
PR4, 8/9 ENDEC, 4-burst Servo

SERIAL PORT REGISTER DEFINITIONS (continued)

Complete Register String ID	A3	A2	A1	A0	S2	S1	S0	R/W	
Data Level Threshold Register	0	1	1	0	0	1	0	0	64H
	Bit 7	X	Factory reserved bit. Must set to 0 in application						
	Bits 6-0	LD6-0	Data level qualification threshold voltage if WP/LT Register : ALE = 0 (Fixed levels) Prior to SFC : Lth (mV) = 4.784 • LD + 26 After SFC : Lth (mV) = 3.768 • LD 32 ≤ LD ≤ 127 if WP/LT Register : ALE = 1 (Adaptive levels) After SFC : Lth (%) = 0.787 • LD						
Servo Level Threshold Register	0	1	1	1	0	1	0	0	74H
	Bit 7	X	Factory reserved bit. Must set to 0 in application						
	Bits 6-0	LDS6-0	Servo level qualification threshold voltage LStH (mV) = 4.784 • LDS + 26						
Control Test Mode Register	1	0	0	0	0	1	0	0	84H
	Bit 7	EFR	Sample clock source 0 = sample clock is from the DS VCO, normal operation 1 = sample clock is from the TBG output, a test mode						
	Bit 6	-	Factory reserved bit, must be set to 0 in application						
	Bits 5-3	TP3-1	Multiplexed test point selection						
	TP3	TP2	TP1	FUNCTION		TPA+, TPA-		TPB+, TPB-	
	0	0	0	Test Points Off		high impedance		high impedance	
	0	0	1	Equalizer Outputs		Equalizer A		Equalizer B	
	0	1	0	Eq Cont/Phase Det		Equalizer Control		Phase Detect Out	
	0	1	1	Viterbi Survival In		Phase A outputs		Phase B outputs	
	1	0	0	Survival Out/ VCO ÷ 2		Registers A, B		VCO CLK ÷ 2	
	1	0	1	TBG Output		TBG output		Not Used	
	1	1	0	AGC Control		BYP (buffered)		Not Used	
	1	1	1	Not Used					
	Bit 2	VRDT	Enable VRDT input 1 = digital input to the data decoder, used in testing only 0 = Viterbi survival outputs to the data decoder, normal use						
Bit 1	DT	Enable TBG pump down 1 = continuous pump down, for test use only FLTR1+ sinks current; FLTR1- sources current 0 = not in pump down test mode							
Bit 0	UT	Enable TBG pump up 1 = continuous pump up, for test use only FLTR1+ sources current; FLTR1- sinks current 0 = not in pump up test mode							

SSI 32P4903
PRML Read Channel with
PR4, 8/9 ENDEC, 4-burst Servo

Complete Register String ID	A3	A2	A1	A0	S2	S1	S0	R/W	
N Counter Register	1	0	0	1	0	1	0	0	94H
	Bit 7	X	Factory reserved bit. Must set to 0 in application						
	Bits 6-0	N6-0	N Counter $2 < N < 127$						
M Counter Register	1	0	1	0	0	1	0	0 = A4H	
	Bits 7-0	M7-0	M Counter $2 < M < 255$ $FTBG = FREF \cdot [(M+1) + (N+1)]$						
Data Rate Register	1	0	1	1	0	1	0	0 = B4H	
	Bit 7	X	Factory reserved bit. Must set to 0 in application						
	Bits 6-0	DR6-0	$Fvco \text{ (MHz)} = 9/8 \text{ Data Rate} = 0.669 \cdot DR + 5.012$ Write Precomp/Level Threshold Time Constant Register						
Write Precomp/Level Threshold Time Constant Register	1	1	0	0	0	1	0	0 = C4H	
	Bits 7-5	TC3-1	Adaptive Level qualification threshold time constant for Decision Directed Phase Detector. (Valid After SFC)						
	TC3	TC2	TC1	TIME CONSTANT					
	0	0	0	300 ns					
	0	0	1	400 ns					
	0	1	0	500 ns					
	0	1	1	600 ns					
	1	0	0	700 ns					
	1	0	1	800 ns					
	1	1	0	900 ns					
	1	1	1	1000 ns					
	Bit 4	ALE	Enable adaptive level qualification in Decision Directed Phase Detector 1 = adaptive mode 0 = fixed level qualification						
Bit 3	X	Factory reserved bit. Must set to 0 in application							

SSI 32P4903

PRML Read Channel with PR4, 8/9 ENDEC, 4-burst Servo

SERIAL PORT REGISTER DEFINITIONS (continued)

Complete Register String ID	A3	A2	A1	A0	S2	S1	S0	R/W	
Write Precomp/Level Threshold	1	1	0	0	0	1	0	0	C4H
Time Constant Register	Bits 2-0	WPC2-0	Write Precomp setting						
	WPC2	WPC1	WPC0	WRITE PRECOMP MAGNITUDE					
	0	0	0	No precomp					
	0	0	1	3.3% code period shift					
	0	1	0	6.6% code period shift					
	0	1	1	9.9% code period shift					
	1	0	0	13.2% code period shift					
	1	0	1	16.5% code period shift					
	1	1	0	19.8% code period shift *					
	1	1	1	23.1% code period shift **					
Control Operating Register	1	1	0	1	0	1	0	0	D4H
	Bits 7	X	Factory reserved bit. Must set to 0 in application						
	Bit 6	X	Factory reserved bit. Must set to 0 in application						
	Bit 5	BP	Enable bypass of write precoder 1 = enabled 0 = disabled, (normal operation)						
	Bit 4	DB	Enable dual bit interface 1 = dual bit DB1-0 interface enabled 0 = dual bit interface disabled, i.e., byte-wide interface enabled						
	Bit 3	BT	Bypass Time Base Generator 1 = data synchronizer reference frequency is FREF input 0 = data synchronizer reference frequency is TBG output, (normal operation)						
	Bit 2	SD	Disable Data Scrambler/Descrambler 1 = disabled 0 = enabled, (normal operation)						
	Bit 1	GS	DS Phase Detector gain switching 1 = disabled 0 = enabled, (normal operation)						
	Bit 0	DW	Enable Direct Write From Byte-wide NRZ (Bypasses scrambler & ENDEC) 1 = enabled 0 = disabled, (normal operation)						

* valid below 72 Mbit/s only

** valid below 56 Mbit/s only

SSI 32P4903
PRML Read Channel with
PR4, 8/9 ENDEC, 4-burst Servo

Complete Register String ID	A3	A2	A1	A0	S2	S1	S0	R/W	
Sample Loop Control Register	1	1	1	0	0	1	0	0	E4H
Bit 7	SBCC	Maximum servo burst charge pump current 1 = 160 μ A 0 = 100 μ A							
Bits 6-5	SFC1-0	Sync Field Count							
SFC1	SFC0	SYNC FIELD COUNT (CODE CLOCKS)							
0	0	64							
0	1	80							
1	0	96							
1	1	128							
Bit 4	AEGS	Adaptive Equalizer Loop time constant shift 1 = equalizer loop time constant is increased to 3X in the data field relative to the preamble field, i.e., loop gain is reduced to 1/3 0 = equalizer loop time constant same in preamble & data fields							
Bit 3	AED	Enable Adaptive Equalizer on Data Field 1 = adaptive equalizer in use after preamble field, if AEE bit = 1 0 = adaptive equalizer disabled after preamble field							
Bit 2	AEE	Enable Adaptive Equalizer 1 = adaptive equalizer enabled for use in preamble field, and after the preamble field if AED bit = 1 0 = adaptive equalizer disabled							
Bits 1-0	AGC1-0	AGC charge pump current in Sampled AGC mode AGC charge/discharge current (μ A) = 0.29 \cdot AGC \cdot Data Rate (Mbit/s) e.g., for Data Rate = 72 Mbit/s and AGC = 10 = 2 dec charge pump current = 41.8 μ A							
Damping Ratio Control Register	1	1	1	1	0	1	0	0	F4H
Bit 7	X	Don't care							
Bits 6-0	D6-0	Damping amplifier gain A = D \cdot (0.7/127) Damping Ratio = $\frac{A \cdot KVCO \cdot 0.25}{2 \omega_n}$							

SSI 32P4903

PRML Read Channel with PR4, 8/9 ENDEC, 4-burst Servo

PIN DESCRIPTION

POWER SUPPLY PINS

NAME	TYPE	DESCRIPTION
VPA	I	AGC/Filter analog circuit supply
VPF	I	Time Base Generator ECL supply (connect to analog supply)
VPT	I	Time Base Generator PLL analog circuit supply
VPP	I	Data Separator PLL analog circuit supply
VPD	I	TTL Buffer I/O digital supply
VPC	I	Internal ECL, CMOS logic digital supply
VPS	I	Sampled data processor supply
VNA	I	AGC/Filter analog circuit ground
VNF	I	Time Base Generator ECL ground (connect to analog ground)
VNT	I	Time Base Generator PLL analog circuit ground
VNP	I	Data Separator PLL analog circuit ground
VND	I	TTL Buffer I/O digital ground
VNC	I	Internal ECL, CMOS logic digital ground
VNS	I	Sampled data processor ground

ANALOG INPUT PINS

VIA+, VIA-	I	AGC AMPLIFIER INPUTS: Differential AGC amplifier input pins
DP, DN	I	ANALOG INPUTS FOR DATA PATH: Differential analog inputs to data comparators, full-wave rectifier
CP, CN	I	ANALOG INPUTS FOR CLOCK PATH: Differential analog inputs to the clock comparator

ANALOG OUTPUT PINS

TPA+, TPA-	O	TEST PINS: Emitter output test points. Various signals are multiplexed to these test points by the Test Point Control Register. The signals include the equalizer control voltage and output, various timing loop control signals and the Viterbi survival register outputs. The test points are provided to show how the signal is being processed. Internal "pull down" resistors to ground are provided. To save power when not in test mode, the Control Test Register bits 3 - 5 must be set to "0".
TPB+, TPB-	O	TEST PINS: Emitter output test points similar to TPA+ and TPA-. The pins are used to look at the other phase of the interleaved signals.
ATO	O	ANALOG TEST OUT: A test point used to indicate the operation of controlled functions which cannot be easily determined by direct testing of the circuit pins. The selected output is determined by the address in the serial control register.

SSI 32P4903
PRML Read Channel with
PR4, 8/9 ENDEC, 4-burst Servo

ANALOG OUTPUT PINS (continued)

NAME	TYPE	DESCRIPTION
ATRN	O	ANALOG TEST OUT RETURN: A test point used as the ATO return.
ON+, ON-	O	FILTER NORMAL OUTPUTS: These are the filter normal low pass output. They should be AC coupled to the data comparator in the pulse qualifier. Open emitter output with internal pulldown. If driving more than coupling cap, external pull down resistor to GND may be required.
OD+, OD-	O	FILTER DIFFERENTIATED OUTPUTS: These are the filter time differentiated low pass output. They should be AC coupled, for low DC offset, to the clock comparator in the pulse qualifier. Open emitter output with internal pulldown. If driving more than coupling cap, external pull down resistor to GND may be required.
A, B, C, D	O	SERVO OUTPUTS: These outputs are the amplified and offset versions of the voltages captured on the servo hold capacitors. They are offset by an internally generated 0.27V baseline.
MAXREF	O	SERVO REFERENCE OUTPUT: +3.2 VDC reference voltage that represents the maximum output voltage for the A, B, C, and D outputs. Can be used as the reference for an external A/D converter.

4

ANALOG CONTROL PINS

BYP	-	The data AGC integrating capacitor, C _{BYP} , is connected between BYP and VPA. This pin is used when not in servo read mode (SG = 0).
BYPS	-	The servo AGC integrating capacitor, C _{BYPS} , is connected between BYPS and VPA. This pin is used when in servo read mode (SG = 1).
FLTR1+, FLTR1-	-	TBG PLL LOOP FILTER: Differential connection points for the time base generator PLL loop filter components.
FLTR2+, FLTR2-	-	DS PLL LOOP FILTER: Differential connection points for the data separator PLL loop filter capacitor.
RR	-	CURRENT REFERENCE RESISTOR INPUT: An external 1%, 12.1 kΩ resistor is connected from this pin to ground to establish a precise internal reference current for the data separator and the time base generator DACs.
VRX	-	FILTER REFERENCE RESISTOR INPUT: An external 1%, 12.1 kΩ resistor is connected from this pin to ground to establish a precise PTAT (proportional to absolute temperature) reference current for the filter DACs.
VRC	-	AGC REFERENCE VOLTAGE: VRC is derived by a bandgap reference from VPA.

SSI 32P4903

PRML Read Channel with

PR4, 8/9 ENDEC, 4-burst Servo

PIN DESCRIPTION (continued)

DIGITAL INPUT PINS

NAME	TYPE	DESCRIPTION
LOWZ	I	LOW-Z MODE INPUT: TTL compatible CMOS control pin which, when pulled high, the input impedance is reduced to allow rapid recovery of the input coupling capacitor. When pulled low, keeps the AGC amplifier and filter input impedance high. An open pin is a logic high.
FASTREC	I	FAST RECOVERY: TTL compatible CMOS control pin which, when pulled high, puts the AGC charge pump in the fast decay mode. An open pin is a logic high.
PDWN	I	POWER DOWN CONTROL: CMOS power control pin. When set to logic low, the entire chip is in sleep mode with all circuitry, except serial port, shut down. This pin should be set to logic high in normal operating mode. Selected circuitry can also be shut down by the Power Down Register but is overridden by this pin. Do not leave open.
HOLD	I	AGC HOLD CONTROL INPUT: TTL compatible CMOS control pin which, when pulled low, holds the AGC amplifier gain constant by turning off the AGC charge pump. The AGC loop is active when this pin is either at high or open.
FREF	I	REFERENCE FREQUENCY INPUT: Reference frequency for the time base generator. FREF may be driven either by a direct coupled TTL signal or by an AC coupled ECL signal. When bits 2 or 7 of the Control Test Register are set, FREF replaces the VCO as the input to the data separator.
WCLK	I	WRITE CLOCK: TTL compatible CMOS input that latches in the data at the selected NRZ interface on the rising edge. Must be synchronous with the write data NRZ input. For short cable delays, WCLK may be connected directly to pin RCLK. For long cable delays, WCLK should be connected to an RCLK return line matched to the NRZ data bus line delay. An open pin is at logic high.
RG	I	READ GATE: TTL compatible CMOS input that, when pulled high, selects the PLL reference input and initiates the PLL synchronization sequence. A high level selects the read data input and enables the read mode/address detect sequences. A low level selects the time base generator output. An open pin is at logic high.
WG	I	WRITE GATE: TTL compatible CMOS input that, when pulled high, enables the write mode. An open pin is at logic high.
SG	I	SERVO GATE: TTL compatible CMOS input that, when pulled high, enables the servo read mode. An open pin is at logic high.
VRDT	I	VITERBI READ DATA: A TTL or ac coupled PECL compatible input to the data separator back end, for testing purposes only. This pin is controlled by the VRDT bit in the Control Test Register.

SSI 32P4903
PRML Read Channel with
PR4, 8/9 ENDEC, 4-burst Servo

DIGITAL INPUT PINS (continued)

NAME	TYPE	DESCRIPTION
DWR	I	DIRECT WRITE MODE 2 ENABLE: Enables DWI, \overline{DWI} inputs to the write data flip-flop when input is low. TTL-compatible CMOS levels. Open pin is at logic high. When active, overrides Bit 0 selection in Control Operating Register.
DWI, \overline{DWI}	I	DIRECT WRITE INPUTS: Inputs connect to the toggle input of the write data flip-flop when DWR is low. PECL input levels. Can be left open.
STROBE	I	SERVO STROBE INPUT: Active high enable for charging of an individual hold capacitor during a servo burst capture. The falling edge of STROBE will increment an internal counter that determines which of the four hold capacitors will be charged during the next strobe pulse. TTL-compatible CMOS levels. Open pin is at logic high.
\overline{RESET}	I	RESET CONTROL INPUT: Active low reset for discharging of the four internal servo burst hold apacitors for channels A, B, C, and D. TTL-compatible CMOS input levels. Open pin is at logic high.

4

DIGITAL BI-DIRECTIONAL PINS

NRZ0-7	I/O	BYTE WIDE NRZ DATA PORT: TTL compatible CMOS bi-directional input/output. Input to the encoder when WG is high. Output from the decoder when RG is high. Can be left open if not used. Active when Bit 4 of Control Operating Register is set to 0.
NRZP	I/O	NRZ DATA PARITY BIT: Active when in Byte Wide mode. TTL compatible CMOS bi-directional input/output. Generates even read parity when RG is high, and accepts even write parity when WG is high. Can be left open if not used.
DB0-1	I/O	DUAL BIT NRZ DATA PORT: TTL compatible CMOS bi-directional input/output. Input to the encoder when WG is high. Output from the decoder when RG is high. Can be left open if not used. Active when Bit 4 of Control Operating Register is set to 1.

DIGITAL OUTPUT PINS

RCLK	O	READ REFERENCE CLOCK: A multiplexed clock source used by the controller. When RG is low, RCLK is synchronized to the time base generator output, FTBG. When RG goes high, RCLK remains synchronized to FTBG until the SFC is reached. At that time, RCLK is synchronized to the data separator VCO. During a mode change, no glitches are generated and no more than one lost clock pulse will occur. CMOS output levels.
WD, \overline{WD}	O	WRITE DATA: Write data flip-flop output. The data is automatically re-synchronized (independent of the delay between RCLK and WCLK) to the reference clock FTBG, except in Direct Write mode 2. Differential PECL output levels.
RDS	O	SERVO READ DATA: Read Data Pulse output for servo read data. Active low CMOS output. Output active when SG is high, and high when SG is low.
PPOL	O	SERVO READ DATA POLARITY: Read Data Pulse polarity output for servo read data. Active high CMOS output. A negative swing servo read data leads to a low output of PPOL and a positive swing servo read data leads to a high output of PPOL. Output active when SG is high.

SSI 32P4903

PRML Read Channel with PR4, 8/9 ENDEC, 4-burst Servo

PIN DESCRIPTION (continued)

SERIAL PORT PINS

NAME	TYPE	DESCRIPTION
SCLK	I	SERIAL DATA CLOCK: Positive edge triggered clock input for the serial data. CMOS input levels.
SDATA	I	SERIAL DATA: Input pin for serial data; The first bit is the R/W bit and is always set to 0. The next three bits are the device select bits and are always written S0 = 0, S1 = 1, S2 = 0. The following four bits are the address bits A0 - A3 and the last 8 are the data bits D0-D7. The bits are entered LSB first, MSB last. CMOS input levels.
SDEN	I	SERIAL DATA ENABLE: A high level input enables data loading. The data is internally parallel latched when this input goes low. CMOS input levels.

SSI 32P4903

PRML Read Channel with PR4, 8/9 ENDEC, 4-burst Servo

ELECTRICAL SPECIFICATIONS

ABSOLUTE MAXIMUM RATINGS

Operation beyond the maximum ratings may damage the device.

PARAMETER	RATING
Positive 5V Supply Voltage (Vp)	-0.5 to 7V
Storage Temperature	-65 to 150°C
Solder Vapor Bath	215°C, 90 sec, 2 times
Junction Operating Temperature	+130°C
Output Pins	±10 mA
Analog Pins	±10 mA
Voltage Applied to other Pins	-0.3V to Vp + 0.3V

4

Recommended Operating Conditions

Unless otherwise specified, the recommended operating conditions are as follows: 4.5V < POSITIVE SUPPLY VOLTAGE < 5.5V, 0°C < T (ambient) < 70°C, and 25°C < T(junction) < 135°C. Currents flowing into the chip are positive. Current maximums are currents with the highest absolute value.

POWER SUPPLY CURRENT AND POWER DISSIPATION

PARAMETER	CONDITION	MIN	NOM	MAX	UNIT
ICC (VPn)	Outputs and test point pins open Ta = 27°C		150	225	mA
PWR Power Dissipation Normal Mode	Outputs and test point pins open, Ta = 27°C		750	1240	mW
PWR Data Separator Off	Power Down Register = 2d		340	580	mW
PWR Data Separator & TBG Off	Power Down Register = 6d		310	530	mW
PWR Idle through serial port	Power Down Register = 7d			20	mW
Idle	$\overline{\text{PDWN}}$ = low			5	mW

DIGITAL INPUTS

TTL Compatible CMOS Inputs

Input low voltage	V _{IL}		-0.3		0.8	V
Input high voltage	V _{IH}		2		VPD + 0.3	V
Input low current	I _{IL}	V _{IL} = 0.4V	-200			μA
Input high current	I _{IH}	V _{IH} = 2.4V			20	μA

SSI 32P4903

PRML Read Channel with PR4, 8/9 ENDEC, 4-burst Servo

DIGITAL INPUTS (continued)

FREF and VRDT Inputs

PARAMETER	CONDITION	MIN	NOM	MAX	UNIT
Input low voltage	V_{IL}			0.8	V
Input high voltage	V_{IH}	2			V
Input low current	I_{ILF} $V_{IL} = 0.4V$	-250			μA
Input high current	I_{IHF} $V_{IH} = 2.4V$			500	μA

CMOS Inputs

Input Low Voltage	V_{ILC}	$V_{PC} = 5V$			1.5	V
Input High Voltage	V_{IHC}	$V_{PC} = 5V$	3.5			V

Pseudo ECL Compatible Inputs

Input Low Voltage	V_{IL}		$VPD - 2.0$		$V_{IH} - 0.25$	V
Input High Voltage	V_{IH}		$VPD - 1.1$		$VPD - 0.4$	V
Input Current			-100		+100	μA

DIGITAL OUTPUTS

CMOS Outputs

Output low voltage	$I_{OL} = +2 \text{ mA}$				0.45	V
Output high voltage	$I_{OH} = -100 \mu A$		$0.7 \cdot VPD$			V

Digital Differential Outputs (WD, \overline{WD})

Output Low Voltage	$I_{OL} = 2 \text{ mA}$	$VPD - 1.9$			$VOH - 0.3$	V
Output High Voltage	$I_{OH} = 2 \text{ mA}$	$VPD - 1.4$			$VPD - 0.5$	V
Output Sink Current				3.2		mA

TEST POINT OUTPUT LEVELS

Test Point Output TPA+, TPA- TPB+, TPB-				0.8		V_{p-pd}
ATO Test Point	$R_{load} \geq 10 \text{ M}\Omega$	0			1	V

SSI 32P4903

PRML Read Channel with PR4, 8/9 ENDEC, 4-burst Servo

SERIAL PORT TIMING

Refer to Figure 8

PARAMETER	CONDITION	MIN	NOM	MAX	UNIT
SCLK Data Clock Period	T _C	100			ns
SCLK low time	T _{CKL}	40			ns
SCLK high time	T _{CKH}	40			ns
Enable to SCLK	T _{SENS}	30			ns
SCLK to disable	T _{SENH}	30			ns
Data set-up time	T _{DS}	15			ns
Data hold time	T _{DH}	15			ns
SDEN min. low time	T _{SL}	200			ns

4

AGC CHARACTERISTICS

Unless otherwise specified, recommended operating conditions apply.

AGC Amplifier

The input signals are AC coupled to VIA+ and VIA-. ON+ and ON- are ac coupled to DP and DN. Integrating capacitor CBYP = 1000 pF, is connected between BYP and VPA. Integrating capacitor CBYPS = 1000 pF, is connected between BYPS and VPA. Unless otherwise specified, the output is measured differentially at DP and DN, Fin = 5 MHz, the filter frequency f_c = max and the filter boost at f_c = 0 dB. All specifications apply equally to servo and read mode prior to SFC.

Input range	Filter Boost = 0 dB @ f_c $5 \text{ MHz} \leq f_c \leq 18 \text{ MHz}$, Fin = f_c	20		250	mVp-pd
Input range	Filter Boost = 11 dB @ f_c $9 \text{ MHz} \leq f_c \leq 18 \text{ MHz}$, Fin = f_c	20		200	mVp-pd
DP/DN voltage	VIA+ = 0.1 Vp-pd 1,1,-1,-1,— pattern	1.15	1.35	1.55	Vp-pd
DP/DN voltage variation	$20 \text{ mVp-pd} < \text{VIA+} < 250 \text{ mVp-pd}$			5	%
Gain range		1		64	V/V
Gain sensitivity	BYP voltage change		38		dB/V
Differential input impedance	LOWZ = low	4	5.3	7.7	k Ω
	LOWZ = high		275		Ω
Single-ended input impedance	LOWZ = low		1.7		k Ω
	LOWZ = high		100		Ω
Output offset voltage	Gain = 64 V/V	-200		200	mV
Input noise voltage	Gain = 64 V/V, Rs = 0 Ω , FC = 127		15	30	nV/ $\sqrt{\text{Hz}}$

SSI 32P4903

PRML Read Channel with PR4, 8/9 ENDEC, 4-burst Servo

AGC AMPLIFIER (continued)

PARAMETER	CONDITION	MIN	NOM	MAX	UNIT
CMRR	Gain = 64 V/V, FC = 127 Fin = 5 MHz	35			dB
PSRR	Gain = 64 V/V, FC = 127 Fin = 5 MHz	40			dB
Gain decay time	VIA+ = 240 to 120 mVp-pd DP/DN > 0.9 Final Value Data mode, max data rate		21		μs
Gain attack time	VIA+ = 120 to 240 mVp-pd DP/DN < 1.1 Final Value Data mode, max data rate		3		μs

AGC CONTROL SECTION

The input signals are AC coupled into DP/DN, CBYP = 1000 pF to VPA & CBYPS = 1000 pF to VPA.

Decay current Normal	ID	FASTREC = low, SG = low data rate in Mbit/s 24 ≤ data rate ≤ 80	2.9 · 10 ⁻⁷ · data rate		A
Servo Mode Decay current Normal		FASTREC = low, SG = high	8.3		μA
Fast Discharge Current	IDF	FASTREC = high	8 · ID		A
Charge Pump Attack, Current	ICH	0.65 ≤ DP/DN ≤ 0.75 Vp-pd FASTREC = low	17 · ID		A
Fast Attack	ICHF	DP - DN ≥ 0.85 VDC AGC pin open	8.4 · ICH		A
Sample Data AGC Peak Charge Current		0 ≤ AGC ≤ 3 data rate in Mbit/s	2.9 · 10 ⁻⁷ · AGC · data rate		A
Sample Data AGC Peak Discharge Current		0 ≤ AGC ≤ 3 data rate in Mbit/s	2.9 · 10 ⁻⁷ · AGC · data rate		A
BYP Pin Leakage Current		HOLD = low VBYP = VRC	-50	+50	nA
BYPS Pin Leakage Current		HOLD = low VBYS = VRC	-50	+50	nA
VRC Reference Voltage		-200 μA ≤ IO ≤ +200 μA	VPA - 2.55	VPA - 2.05	V

SSI 32P4903

PRML Read Channel with

PR4, 8/9 ENDEC, 4-burst Servo

PULSE QUALIFIER CHARACTERISTICS

General

Unless otherwise specified, a 100 mVp-p sine wave at 5 MHz is AC coupled in VIA+/VIA- inputs, FC = 7.5 MHz and boost = 0 dB.

PARAMETER	CONDITION	MIN	NOM	MAX	UNIT
DP-DN Differential input resistance	Low Z = low	6		13	kΩ
	Low Z = high	0.4	0.8	1.4	kΩ
DP-DN Differential input capacitance				5	pF
CP-CN Differential input resistance		6		13	kΩ
CP-CN Differential input capacitance				5	pF

4

Dual Level Qualifier

Data Level Threshold	LTH	Prior to SFC $L_{TH} (mV) = 4.784 \cdot LD + 26$ $32 \leq LD \leq 127$		LTH		V
Data Level Threshold	LTH	After SFC, ALE = 0 $L_{TH} (mV) = 3.768 \cdot LD + 18$ ALE = 1 $L_{TH\%} = 0.787 \cdot LD$ $32 \leq LS \leq 127$		LTH		V
Servo Level Threshold	LSTH	$L_{STH} (mV) = 4.784 \cdot LDS + 26$ $32 \leq LS \leq 127$	$L_{STH} - 9\%$	LSTH	$L_{STH} + 9\%$	V
RDS Output Pulse Width	PW	DP-DN signal set to exceed amplitude threshold, -90° from CP-CN	18		48	ns
PPOL to RDS Delay Time	PPRD	PPOL rise/fall to RDS fall measured at 1.5V	3		12	ns
Pulse Pairing	PP	Threshold = 50% measured at the falling edge of RDS Fin = 5 MHz, FCS = 40	-3.5		-3.5	ns
PPOL/RDS rise time		0.8V to 2.0V, CL = 15 pF			3	ns
PPOL/RDS fall time		2.0V to 0.3V, CL = 15 pF			4	ns

VITERBI QUALIFIER

See General for input conditions unless otherwise specified.

Viterbi Threshold	VTH	$V_{TH} = 9.94 \cdot VD - 175$ $45 \leq VD \leq 127$	$V_{TH} - 9\%$	VTH	$V_{TH} + 9\%$	mV
-------------------	-----	---	----------------	-----	----------------	----

SSI 32P4903

PRML Read Channel with

PR4, 8/9 ENDEC, 4-burst Servo

PROGRAMMABLE FILTER CHARACTERISTICS

Unless otherwise specified, recommended operating conditions apply. The input signals are AC coupled to VIA+ and VIA-. All specifications identical for identical data and servo register settings.

Data uses C_{BYP} from BYP to VPA and servo uses C_{BYPs} from BYPS to VPA. $VBYP = VRC$

PARAMETER	CONDITION	MIN	NOM	MAX	UNIT
Filter cutoff range	f_{CR} f_c (MHz) = $0.1955 \cdot FC - 0.8782$ 0 dB Boost	3		24	MHz
Filter cutoff frequency	f_c $f_c = 127$, 0 dB Boost		24		MHz
Filter f_c Accuracy	f_{CA} $45 \leq FC \leq 127$	-15		+15	%
	$20 \leq FC \leq 44$	-20		+20	%
OD gain	A_D $F_{in} = 0.67 \cdot f_c$ 0 dB Boost	$0.6 A_N$		$1.2 A_N$	V/V
Boost @ f_c	$FB = 127$, $FC = 127$		12.40		dB
Boost accuracy	$FB = 127$, $45 \leq FC \leq 127$	-1.5		+1.5	dB
	$FB = 71$, $45 \leq FC \leq 127$	-1.25		+1.25	dB
Group Delay Variation	TGD $f_c = 24$ MHz $F = 0.2 f_c$ to f_c , 0 dB Boost	-600		+600	ps
	$f_c = 5$ MHz to 24 MHz $F = 0.2 f_c$ to f_c $FB = 0$ to 127	-3		+3	%
	$f_c = 3$ MHz to 5 MHz $F = 0.2 f_c$ to f_c $FB = 0$ to 127	-7.5		+7.5	%
	$f_c = 8$ MHz to 24 MHz $F = f_c$ to $1.75 f_c$ $FB = 0$ to 127	-4.3		+4.3	%
	$f_c = 3$ MHz to 8 MHz $F = f_c$ to $1.75 f_c$ $FB = 0$ to 127	-6		+6	%
Filter output Dynamic range ON+ - ON-	THD = 2.1% max $F = 0.67 f_c$ CL = 15 pF	1.3			Vp-p
ON+ - ON- output noise voltage, no boost	BW = 100 MHz, $R_s = 50\Omega$ FC = 127, boost = 0 dB AGC gain = min.		3.5	5.5	mV rms
ON+ - ON- output noise voltage, max. boost	BW = 100 MHz, $R_s = 50\Omega$ FC = 127, FB = 127		7	13	mV rms
OD+ - OD- output noise voltage, no boost	BW = 100 MHz, $R_s = 50\Omega$ FC = 127, boost = 0 dB AGC gain = min.		7.3	14	mV rms
OD+ - OD- output noise voltage, max. boost	BW = 100 MHz, $R_s = 50\Omega$ FC = 127, FB = 127		14		mV rms

SSI 32P4903

PRML Read Channel with

PR4, 8/9 ENDEC, 4-burst Servo

PROGRAMMABLE FILTER CHARACTERISTICS (continued)

PARAMETER	CONDITION	MIN	NOM	MAX	UNIT
Filter output sink current, IO-		0.6	1.5		mA
Filter output source current, IO+		2	5		mA
Filter output resistance R _o	single ended			200	Ω
Rx pin voltage V _{RX}	T _a = 27°C		600		mV
	T _a = 127°C		800		mV
Rx resistance	1% fixed value		12.1		kΩ

TRANSVERSAL FILTER CHARACTERISTICS

k _m Range		-0.20		+0.20	
----------------------	--	-------	--	-------	--

TIME BASE GENERATOR CHARACTERISTICS

FREF input range	Control Operating Register BT bit = 0	6		20	MHz
	Control Operating Register BT bit = 1 Control Test Register EFR bit = 1			90	MHz
FREF input pulse width	Control Operating Register BT bit = 0	10			ns
	Control Operating Register BT bit = 1 Control Test Register EFR bit = 1 FREF duty cycle = 50%	5			ns
FTBG frequency range				100	MHz
FTBG jitter	> 10K samples			200	psRMS
M counter range		2		255	
N counter range		2		127	
VCO center frequency FTBG	FLTR1+ - FLTR1- = 0V FTBG = [(0.6692 • DR) + 5.012] MHz RR = 12.1 kΩ	0.8 FTBG		1.2 FTBG	MHz
VCO dynamic range	-2V ≤ FLTR1+ - FLTR1- ≤ +2V FTBG = 65 MHz	±25		±45	%
VCO control gain KVCO	ω _i = 2π • FTBG -1V ≤ FLTR1+ - FLTR1- ≤ +1V	0.12 • ω _i	0.18 • ω _i	0.24 • ω _i	rad/(V-S)
Phase detector gain KD	KD = (2.056 • DR) + 2.09	0.83 • KD		1.17 • KD	μA/rad
KVCO • KD product accuracy		-28		+28	%

4

SSI 32P4903

PRML Read Channel with PR4, 8/9 ENDEC, 4-burst Servo

ELECTRICAL SPECIFICATIONS (continued)

DATA SEPARATOR CHARACTERISTICS

Unless otherwise specified, recommended operating conditions apply.

Read Mode - Byte Wide

PARAMETER	CONDITION	MIN	NOM	MAX	UNIT
Read clock rise time TRRC	0.8V to 2V CL < 15 pF			10	ns
Read clock fall time TFRC	2V to 0.8V CL < 15 pF			10	ns
RCLK pulse width TRD	Except during re-sync	4/9TORC-5		4/9TORC+5	ns
RCLK re-sync period T _{dc2}	TORC = RCLK period	TORC		2(TORC)	ns
NRZx out set-up and hold time TNS, TNH		25			ns

Write Mode - Byte Wide

Write data position accuracy TWD	without precomp CL < 15 pF	TTBG-0.5		TTBG+0.5	ns
Write data rise time TRWD	20% to 80% points 2 kΩ to GND CL < 15 pF			5	ns
Write data fall time TFWD	80% to 20% points 2 kΩ to GND CL < 15 pF			5	ns
Write clock rise time TRWC	0.8V to 2V CL < 15 pF			10	ns
Write clock fall time TFWC	2V to 0.8V CL < 15 pF			8	ns
NRZx set-up time TSNRZ		20			ns
NRZx hold time THNRZ		20			ns

SSI 32P4903

PRML Read Channel with

PR4, 8/9 ENDEC, 4-burst Servo

Read Mode - Dual Bit

PARAMETER		CONDITION	MIN	NOM	MAX	UNIT
RCLK low time	RCL	CL < 15 pF, ≤ 0.8V	8			ns
RCLK high time	RCH	CL < 15 pF, ≥ 2V	7.5			ns
Read clock rise time	TRRC	0.8V to 2V CL < 15 pF			2.5	ns
Read clock fall time	TFRC	2V to 0.8V CL < 15 pF			3.5	ns
DB _{out} (1:0) setup time	DBOS	CL < 15 pF	5			ns
DB _{out} (1:0) hold time	DBOH	CL < 15 pF	5			ns

Write Mode - Dual Bit

WCLK period	TWC	CL < 15 pF	22			ns
WCLK low time	WCL	CL < 15 pF, ≤ 0.8V	7.5			ns
WCLK high time	WCH	CL < 15 pF, ≥ 2V	7.5			ns
DB _{in} (1:0) setup time	DBIS	CL < 15 pF	3			ns
DB _{in} (1:0) hold time	DBIH	CL < 15 pF	6			ns

Write Precompensation

Write precomp time shift magnitude	TPC	TPC = 0.033 • WPC • TTBG 0 ≤ WPC ≤ 7	0.8 • TPC - 0.5		1.2 • TPC + .5	ns
------------------------------------	-----	---	--------------------	--	-------------------	----

Data Synchronizer PLL

VCO center frequency FVCO		FLTR2+ - FLTR2- = 0V FVCO = [(0.6692 • DR) + 5.012] MHz RR = 12.1 kΩ	0.8 FVCO		1.2 FVCO	ns
VCO dynamic range in each direction		-2V ≤ FLTR2+ - FLTR2- ≤ +2V	±20			%
VCO control gain & M, M • KVCO		$\omega_i = 2\pi / TVCO$ M = 2.4 • (DR/127) -0.25V ≤ FLTR2+ - FLTR2- ≤ +0.25V	0.11 • ω_i • M		0.35 • ω_i • M	rad/(V-S)
Charge Pump Transconductance		Gm = 200 μA/V during synchronization	0.60 • Gm		1.58 • Gm	A/V
Idle Mode Phase Detector Gain	KDI	KDI = 0.25 • Gm • M				
Gm • M • KVCO product accuracy			-28		+28	%
A • KVCO product accuracy		A = 0.7 • (DRC/127)	-30		+30	%

SSI 32P4903

PRML Read Channel with

PR4, 8/9 ENDEC, 4-burst Servo

SERVO CHARACTERISTICS

Unless otherwise specified, a 5 MHz sine wave is AC coupled into DP/DN, STROBE and $\overline{\text{RESET}}$ durations are 1.0 μs and SBCC bit is set to '0'.

PARAMETER	CONDITION	MIN	NOM	MAX	UNIT
MAXREF output voltage	$I_{\text{SOURCE}} = 0 \text{ mA}$	3.00	3.22	3.42	V
MAXREF load regulation	$I_{\text{SOURCE}} = 0 \text{ to } 1.5 \text{ mA}$			30	mV
A, B, C, D output low voltage	$I_{\text{SINK}} = 0.1 \text{ mA}$ $\overline{\text{RESET}} = \text{low}$	0.2	0.3	0.4	V
A, B, C, D output high voltage	DP - DN = 1.35 Vp-p	2.90	3.10	3.33	V
A, B, C, D Output Resistance	$I_{\text{SOURCE}}/I_{\text{SINK}} = 0.2 \text{ mA}$			50	Ω
A, B, C, D Gain	$0.3 \text{ Vp-pd} \leq \text{DP-DN} \leq 1.35 \text{ Vp-pd}$	1.9	2.08	2.2	V/Vp-pd
	$0 \text{ Vp-pd} \leq \text{DP-DN} \leq 0.3 \text{ Vp-pd}$	0		2.35	V/Vp-pd
Hold droop	STROBE = low $\overline{\text{RESET}} = \text{high}$			1	mV/ μs
Channel to channel mismatch (relative)	DP - DN = 1.35 Vp-pd @ 5 MHz A-B, C-D			100	mV
	A-C, A-D, B-C, B-D			120	mV
Burst Capture Time	DP - DN = 1.35 Vp-pd $F_{\text{in}} \leq 5 \text{ MHz}$, PK0 = L Output $\geq 95\%$ of final value			1	μs
Burst Reset Time	DP - DN = 1.35 Vp-pd $\overline{\text{RESET}} = \text{low}$ Output $\leq 5\%$ of final value			0.5	μs
Reset turn-on delay	From $\overline{\text{RESET}}$ fall @ 1.2V			150	ns
Minimum Time between STROBE Pulses		20			ns
$\overline{\text{RESET}}$ to STROBE minimum time	$\overline{\text{RESET}}$ rise to STROBE rise			150	ns

SSI 32P4903

PRML Read Channel with PR4, 8/9 ENDEC, 4-burst Servo

MODE CONTROL

WG	RG	DEVICE MODE	DESCRIPTION
0	0	Idle Mode	DS VCO locked to FTBG. NRZ1-0 tri-stated.
0	1	Data Read Mode	DS PLL acquisition, adaptive equalizer training, code word boundary search and detect, decode, sync byte detect, and NRZ data output. DS VCO switched from FTBG to read data after preamble detect. RCLK gen. input switched from FTBG to DS VCO. RCLK re-synchronized to read data at code word boundary detect. NRZ7-0, DB1-0 active.
1	0	Data Write Mode	Write mode preamble insertion and data write. DS VCO locked to FTBG. RCLK synchronized to FTBG. WD and \overline{WD} active. NRZ7-0, DB1-0 tri-stated.
1	1	Read Override	RG overrides WG which causes any write in progress to cease and Data Read Mode to be entered.

4

WRITE PRECOMP CONTROL

Write precomp magnitude is set by the value in the Write Precomp Register. The Write Precomp Register bits are as follows:

BIT	NAME	FUNCTION
0	WPC0	Write Precomp Bit 0
1	WPC1	Write Precomp Bit 1
2	WPC2	Write Precomp Bit 2
3	X	Factory reserved bit. Must set to 0 in application
4	ALE	Adaptive Level Equalization enable
5	TC1	Level Time Constant Bit 1
6	TC2	Level Time Constant Bit 2
7	TC3	Level Time Constant Bit 3

T_{TBG} is the period of the reference frequency provided by the internal time base generator.

WPC2	WPC1	WPC0	WPC Value	Shift
0	0	0	0	None
0	0	1	1	3.3% T_{TBG}
0	1	0	2	6.6% T_{TBG}
0	1	1	3	9.9% T_{TBG}
1	0	0	4	13.2% T_{TBG}
1	0	1	5	16.5% T_{TBG}
1	1	0	6	19.8% T_{TBG} *
1	1	1	7	23.1% T_{TBG} **

* valid below 72 Mbit/s only

** valid below 56 Mbit/s only

SSI 32P4903

PRML Read Channel with PR4, 8/9 ENDEC, 4-burst Servo

WRITE PRECOMP CONTROL (continued)

BIT N-1	BIT N	BIT N+1	BIT N COMPENSATION
0	1	0	None
1	1	0	Late
1	1	1	Late

Late = Bit N is time shifted toward the N+1 bit by the programmed magnitude

TC3	TC2	TC1	NOMINAL FILTER TIME CONSTANT
0	0	0	300 ns
0	0	1	400 ns
0	1	0	500 ns
0	1	1	600 ns
1	0	0	700 ns
1	0	1	800 ns
1	1	0	900 ns
1	1	1	1000 ns

Adaptive threshold level filter time constant (Decision directed phase detector, after SFC)

TEST POINT CONTROL

The test points are controlled by the TP1, TP2, and TP3 bits of the Control Test Register.

TP3	TP2	TP1	FUNCTION	TPA+, TPA-	TPB+, TPB-
0	0	0	Test Outputs Powered Down		
0	0	1	Equalizer Outputs	Equalizer A	Equalizer B
0	1	0	Equalizer/Phase Detector	Equalizer Control	Phase Detect Out
0	1	1	Viterbi Survival In	Phase A outputs	Phase B outputs
1	0	0	Survival Out/VCO/2	Registers A, B	VCO CLK/2
1	0	1	TBG Fout	TBG Fout	Not Used
1	1	0	AGC Control	AGC Control	Not Used
1	1	1	Not Used		

SSI 32P4903

PRML Read Channel with

PR4, 8/9 ENDEC, 4-burst Servo

TEST POINT CONTROL (continued)

The test point functions are further described below:

1. Test 1, Equalizer Outputs. The equalizer output "1" and "0" values can be observed.
2. Test 2A, Equalizer Control. The integrated control voltage produced by the deviation of the "0" samples from ideal is observed.
Test 2b, Phase Detect Out. The sampled data phase detector output is observed.
3. Test 3, Viterbi Survival In. The four inputs to the two interleaved Viterbi registers are observed by single ended probing TPA+/TPA-, TPB+/TPB-.
4. Test 4, Viterbi Survival Out. The two outputs of the two interleaved Viterbi registers are observed by single ended probing TPA+/TPA-. Test 4a, Data separator PLL output observed on TP \pm .
5. Test 5, VCO Outputs. The TBG PLL outputs are observed.
6. Test 6, AGC Control. The integrated control voltage produced by the deviation of the "1" samples from ideal is observed.

To save power in normal operation, the TEST POINTS SHOULD BE POWERED DOWN by selecting TP1 = TP2 = TP3 = "0" the Control Test Mode Register.

DAC TESTING

A testing capability for some of the internal DACs has been incorporated. A DAC is selected by the serial port address register (the last register with DAC sent to serial port). The ATO pin is enabled by setting bit 7 in the Power Down Register to 1. The selected DAC output is buffered, then fed to the ATO pin. A measurement return pin ATRN is also provided. The ATO pin voltage is not a direct measure of the DAC output, so it cannot be used to measure the absolute value of the DAC output. The intention of the test point is to check DAC functionality and monotonicity. The following DAC's functionality can be measured at ATO: FC(filter cutoff frequency), FB(filter boost), VD(Viterbi threshold), LDP(level positive threshold), LDN(level negative threshold), IDR(data rate), WP(write precomp), and DRC(damping ratio).

DIAGNOSTIC / OPTIMIZATION TEST MODES

Some disk drive diagnostic tests and operating optimization could be performed by observing the Equalizer and AGC Control voltages and measuring their change with different conditions. For example, the Equalizer Control Voltage ("0" sample values) is affected by the Continuous Time Filter / Equalizer setting, the head flying height, and the head gap length. The AGC Control Voltage ("1" sample values) are also affected by the previously mentioned factors and by magnetic nonlinearities. The effectiveness of Write Precomp compensating the nonlinearities could be evaluated by observing the AGC Control Voltage difference of a maximum transition di-bit pattern with a pattern with minimum transitions.

SSI 32P4903 PRML Read Channel with PR4, 8/9 ENDEC, 4-burst Servo

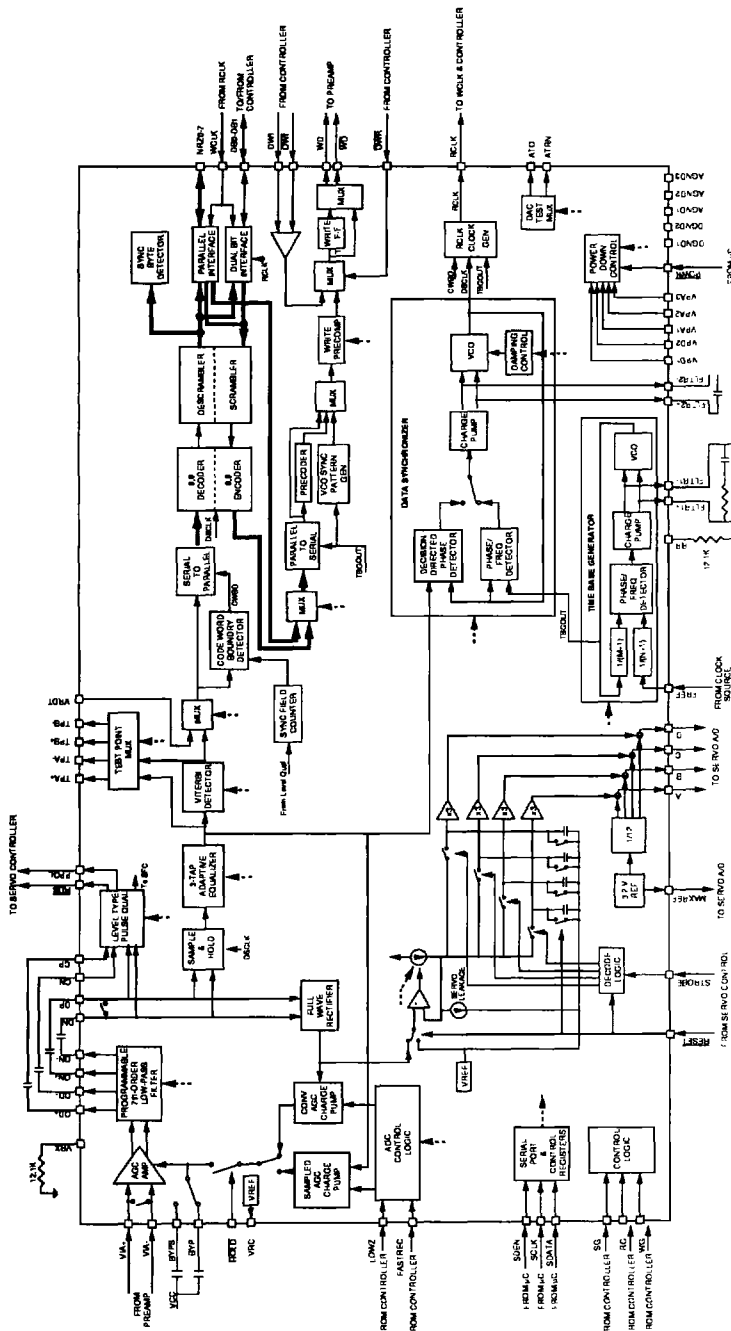
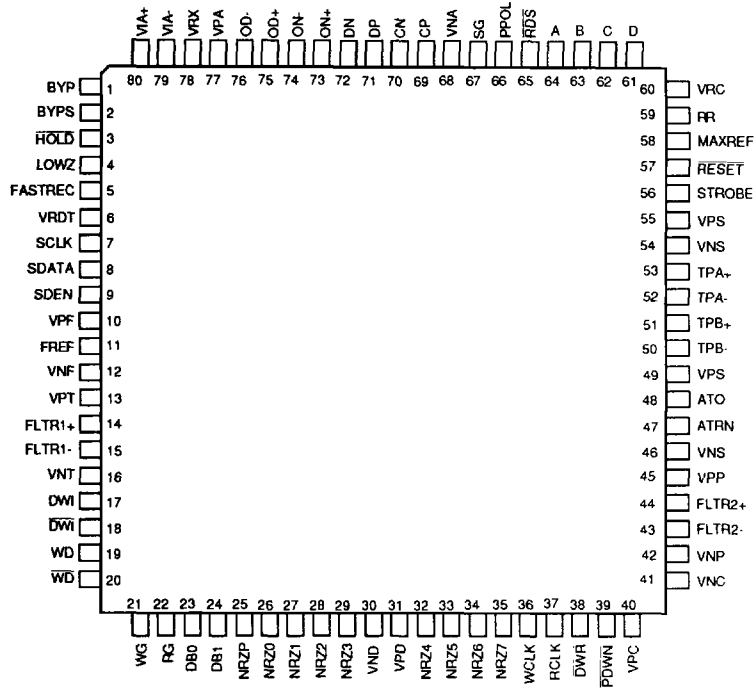

FIGURE 11: SSI 32P4903 Application Diagram

SSI 32P4903 PRML Read Channel with PR4, 8/9 ENDEC, 4-burst Servo

PACKAGE PIN DESIGNATIONS

(Top View)



80-Lead TQFP

CAUTION: Use handling procedures necessary for a static sensitive component.

ORDERING INFORMATION

PART DESCRIPTION	ORDER NUMBER	PACKAGE MARK
SSI 32P4903 80-Lead TQFP	32P4903-CGT	32P4903-CGT

No responsibility is assumed by Silicon Systems for use of this product nor for any infringements of patents and trademarks or other rights of third parties resulting from its use. No license is granted under any patents, patent rights or trademarks of Silicon Systems. Silicon Systems reserves the right to make changes in specifications at any time without notice. Accordingly, the reader is cautioned to verify that the data sheet is current before placing orders.

Silicon Systems, Inc., 14351 Myford Road, Tustin, CA 92680-7022 (714) 573-6000, FAX (714) 573-6914