

INTRODUCTION

From now on, you can hook your product onto the inter-net directly. Put the PC aside, HMS91C7432 do all the jobs that the PC do for inter-net connection.

HMS91C7432 is a CMOS IC with a complete TCP/IP protocol suite to facilitate inter-net connection for embedded application. The built-in email engine can transform any ASCII message to standard email format. It sends and receives email; conduct the whole log on process automatically. Built-in PPP protocol handle user-ISP handshaking and authentication process automatically. The HMS91C7432 also includes the MODEM driver, no code should write to drive the MODEM (parameter of modem must be transferred by the host to make HMS91C7432 works with your modem).

Using HMS91C7432 is easy, a simple 8 bit parallel port (8 bit data plus 4 control lines) bridge the IC with your application. A serial DTE port is ready for directly connect to an onboard modem or through DTE interface to a serial modem.

Make your product inter-net able, just add an HMS91C7432 on your BOM.

HMS91C7432 features and functions

- Implementation of the complete TCP/IP protocol suite
- Built-in Email sending and reception function.
- Standard SMTP protocol stack.
- Standard POP3 protocol stack.
- Standard PPP protocol stack to facilitate dial-up network log on.
- Standard DNS protocol stack, resolve URL with dynamic DNS server.
- Serial modem driver built-in.
- Support V.90 56Kflex modem or lower.
- 8 bit parallel interface to the user application.
- Serial DTE port for ease of modem interface.
- 5V or 3.3V operation voltage
- 20 pins SOP package

Detail description of HMS91C7432 function and its application

TCP/IP protocol suite is the key to inter-net access. Email; Home Page materials and all the data traffic on the inter-net are carry out by using the TCP/IP well defined format. Time before HMS91C7432 exist, most inter-net connection were to be handled by the PC. Hand held devices and equipments must be attached to the PC to get access to the inter-net. Now the era of "PC-free" inter-net connection has come. With HMS91C7432, you can make your product be able to send and receive email; surf on the WWW and even "TALK" to another device through the inter-net, by just plugging the telephone line onto it.

The core of the HMS91C7432 is a complete TCP/IP protocol suite. Files and messages pass to the HMS91C7432 will be transformed into the appropriate format and packets to conform the inter-net standard. This transformation is transparent to the user's application.

On top of the TCP/IP core, there is an Email engine built-in. User's program just needed to inform the HMS91C7432 an email is going to send and follow with the email body. HMS91C7432 will then wake up the modem and dial the ISP to log on the mail server. The mail will be sent when log on has success. HMS91C7432 complete this whole process fully automatic.

Reception of Email is as simple as getting email on the PC. The application program send a "Receive Email" command to the HMS91C7432, it dial up the ISP and log on

the server, then it check and download any email automatically. Each message will be stored in the RAM buffer, HMS91C7432 will notify the application program an email has come and waiting for retrieve.

The built-in PPP module handles the "Log on process". This is a standard protocol to pass the user's account ID and the password to the ISP. This module handles the authentication and "Handshaking". User's program just pass the user's ID and password to HMS91C7432 and the PPP do it all.

HMS91C7432 (later version only) also equip with a FTP module to facilitate file transfer and file downloading from the FTP site. This function is especially good for remote system update and game download for hand-held game inter-net access.

The standard serial DTE interface on the HMS91C7432 ease the modem connection. The built-in modem driver support V.90 and 56K flex dual modem or lower.

HMS91C7432 is controlled by an 8 bit data/command port. This port accepts command passed by the host MCU. Incoming and outgoing message will be passed between the host and the HMS91C7432 through this port as well.

Specifications of HMS91C7432

The HMS91C7432 TCP/IP communication controller is manufactured in advance CMOS process.

The HMS91C7432 implement complete TCP/IP protocol suite includes PPP; IP; ICMP; TCP; UDP; DNS; SMTP; POP3 protocol and additionally a general MODEM driver.

The HMS91C7432 is built-in with 96Kb SRAM (12K x 8) for communication and buffering, A full duplex UART as DTE for ease of serial modem connection.

The HMS91C7432 has an 8 bits Data/Command port and 4 control pins to facilitate control and communication between the Host MCU and the modem. There are only 20 simple commands, each of which is a single byte long, to establish and to complete the whole internet communication. 45 respond codes for the Host MCU to monitor the communication status.

Extremely low external component count. Very low power consumption.

Features :

- Implement TCP/IP protocol suit.
- SMTP for sending email
- POP3 for receiving email
- PPP for dialup network log on and hand shaking.
- DNS protocol to resolve IP address from URL
- Full static operation
- Full Duplex 56K/115Kbps UART port for modem DTE connection.
- Speed range up to 22.118MHz
- 8 bits Bi-directional Data/Command bus.
- Modem driver included
- Power control modes
 - ✓ Active mode
 - ✓ Power-down mode
- Dissipating Current
 - Active 25mA
 - Power-down 10uA max.
- 20 single byte easy commands
- 45 respond codes
- **Package type 20-SOP**

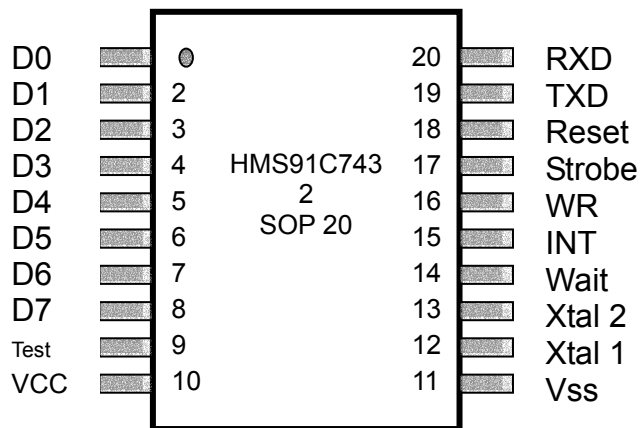

Operating voltage	3.3V +/- 10%
Dissipating Current	
Active mode	25 mA
Power down mode	10uA max.
Oscillation Frequency	11.0592 Mhz
Operating Temperature	-40 to +85°C
Storage Temperature	-65 to +150°C

Specifications of HMS91C7432

MNEMONIC	PIN	TYPE	NAME AND FUNCTION
Vss	14		Ground : 0V reference.
Vcc	10		Power Supply : This is the power supply voltage for normal, and power-down operation.
D0 to D7	1 – 8	I/O	Data/Command Port : This is an 8 bit bi-directional I/O port with internal pull-ups. This port is for data transfer between Host MCU, it also serves as command reception and responds code issuance port from and to the Host MCU.
WAIT	14	Out	WAIT : Handshake signal. When low it indicates that is OK to start a cycle (assert a strobe), when high it indicates that it is OK to end the cycle (de-assert a strobe).
INT	15	Out	INT : Active LOW Output a request to the Host MCU if data/respond code are to be sent.
WR	16	In	WRITE : Active LOW write enable pin. Set this pin LOW for a write cycle. Set this pin HIGH for a read cycle.
STROBE	17	In	STROBE : Data strobe signal. Active low indicates a Data_Read or Data_Write operation is in process.
RXD	20	In	RXD : UART serial input port.
TXD	19	Out	TXD : UART serial output port.
RESET	13	In	RESET : A high level on this pin for 2us while the oscillator is running resets the device.
TEST	9	In	TEST : Test pin, should be stuck at zero when normal operation.
XTAL 1	11	In	XTAL1 : Input to the inverting oscillator amplifier and input to the internal clock generator circuits.
XTAL 2	12	Out	XTAL2 : Output to the inverting oscillator amplifier.

Table 1. Pin descriptions

Specifications of HMS91C7432

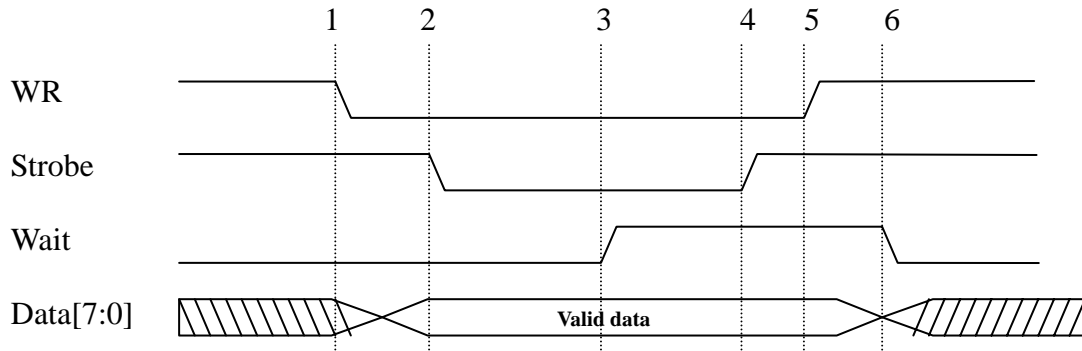

Figure 1. Data Write Cycle waveform

Data Write cycle phase transitions:

1. The Write line is asserted and the data is output to the parallel port
2. The data strobe is asserted, since WAIT is asserted low
3. The port waits for the acknowledge from the HMS91C7432 (WAIT de-asserted)
4. The data strobe is de-asserted
5. The write cycle ends
6. WAIT is asserted low to indicate that the next cycle may begin

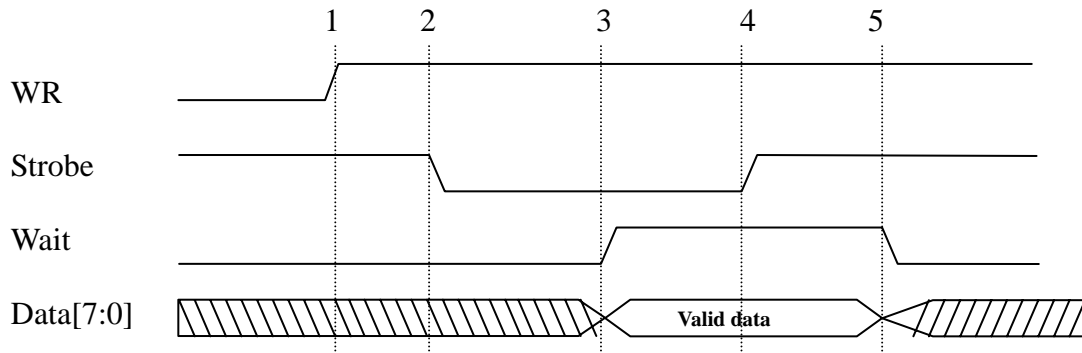

Figure 2. Data Read Cycle waveform

Data Read cycle phase transitions:

1. The Write line is set to HIGH to indicate read request
2. The data strobe is asserted, since WAIT is asserted low
3. The port waits for the acknowledge from the HMS91C7432 (WAIT de-asserted)
4. The data strobe is de-asserted after data is stored and the read cycle ends
5. WAIT is asserted low to indicate that the next cycle may begin

Specifications of HMS91C7432

□ DC Characteristics

($T_a = -20$ To $+85$, $V_{cc} = 5V \pm 10\%$, $V_{ss} = 0V$)

SYMBOL	PARAMETER	TEST CONDITIONS	LIMITS		UNIT
			MIN	MAX	
V_{IL}	Input low voltage,except Reset		-0.5	$0.2V_{cc}-0.1$	V
V_{IL1}	Input low voltage,Reset		-0.5	$0.2V_{cc}+0.1$	V
V_{IH}	Input high voltage,except Xtal1,Reset		$0.7V_{cc}$	$V_{cc}+0.5$	V
V_{IH1}	Input high voltage,Xtal1		$0.7V_{cc}$	$V_{cc}+0.5$	V
V_{IH2}	Input high voltage, Reset		$0.6V_{cc}$	$V_{cc}+0.5$	V
V_{OL}	Output low voltage,D0~D7,Strobe, WR,INT,Wait	$I_{OL} = 3.5mA$		1.0	V
V_{OH}	Output high voltage, D0~D7,Strobe, WR,INT,Wait	$I_{OH} = -25\mu A$	$0.75V_{cc}$		V
I_{IL}	Logical 0 input current, D0~D7,Strobe, WR,INT,Wait	$V_{IN} = 0.45V$	-10	-50	μA
I_{TL}	Logical 1-to-0 input current, D0~D7,Strobe,WR,INT,Wait	$V_{IN} = 3.0V$	-65	-650	μA
I_{CC}	Power supply current : Active mode@11.0592MHz Power-down mode @11.0592MHz	$V_{cc} = 5V$		16 10	mA μA

NOTES :

- See Figure 3 through 5 for I_{cc} test conditions. Minimum V_{cc} for power down is 2V.
- Under steady state (non-transient) conditions, I_{OL} must be externally limited as follows :
 Maximum I_{OL} per port : 10mA
 Maximum I_{OL} per 8-bit port D0~D7,Strobe,WR,INT,Wait : 15mA
 Maximum total I_{OL} for all output pins : 71mA
 If I_{OL} exceeds the test condition, V_{OL} may exceed the related specification.Pins are not guaranteed to sink current greater than the listed test conditions.

Specifications of HMS91C7432

□ DC Characteristics(Cont.)

(Ta = -20 To +85 , Vcc = 3.3V±10%, Vss = 0V)

SYMBOL	PARAMETER	TEST CONDITIONS	LIMITS		UNIT
			MIN	MAX	
V _{IL}	Input low voltage,except Reset		-0.5	0.8	V
V _{IL1}	Input low voltage, Reset		-0.5	0.8	V
V _{IH}	Input high voltage,except Xtal1,Reset		0.7V _{cc}	V _{cc} +0.3	V
V _{IH1}	Input high voltage,Xtal1		0.7V _{cc}	V _{cc} +0.3	V
V _{IH2}	Input high voltage,Reset		0.6V _{cc}	V _{cc} +0.3	V
V _{OL}	Output low voltage,D0~D7,Strobe, WR,INT,Wait	I _{OL} = 1.6mA		0.45	V
V _{OH}	Output high voltage, D0~D7,Strobe, WR,INT,Wait	I _{OH} = -20μA	2.7		V
I _{IL}	Logical 0 input current, D0~D7,Strobe, WR,INT,Wait	V _{IN} = 0.45V	-6	-50	μA
I _{TL}	Logical 1-to-0 input current, D0~D7,Strobe,WR,INT,Wait	V _{IN} = 2.0V	-40	-250	μA
I _{CC}	Power supply current : Active mode@11.0592 Power-down mode @11.0592	V _{cc} = 3.3V		10 10	mA μA

Specifications of HMS91C7432

DC Characteristics(Cont.)

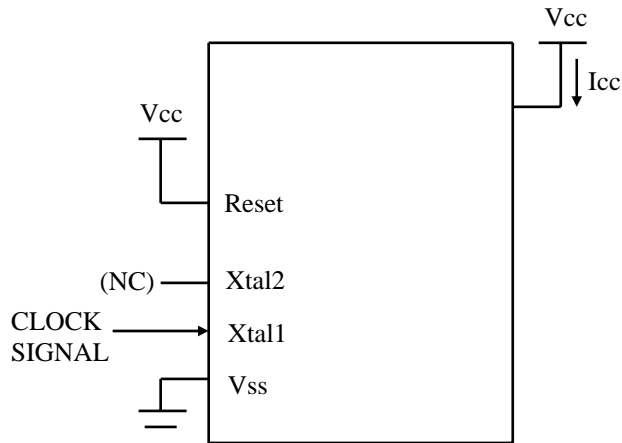

All other pins are disconnected.

Figure 3. Icc Test Condition, Active Mode

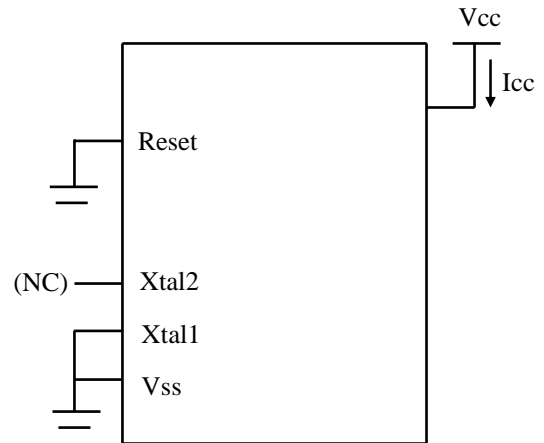

All other pins are disconnected.

Figure 4. Icc Test Condition, Power Down Mode

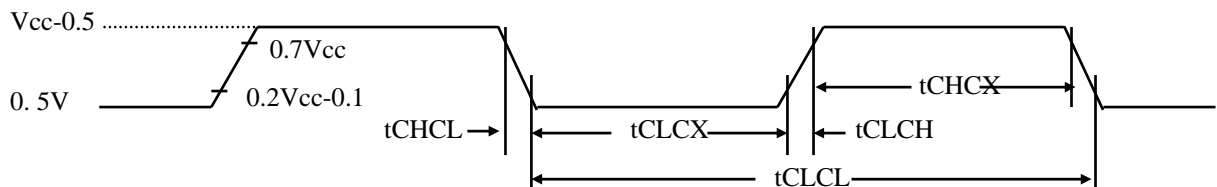

Figure 5. Clock signal Waveform for Icc Tests in Active Mode

$$tCLCH = tCHCL = 5ns$$

NOTES :

1. Icc(active mode) is measured with:
 Xtal1 driven with $tCLCH = tCHCL = 5ns$, $VIL = Vss + 0.5V$, $VIH = Vcc - 0.5V$, $X2 = N.C.$
 Reset = Vcc, all other pins are disconnected.
 Icc would be slightly higher if a crystal oscillator is used (appr. 1mA)
2. Icc(power down mode) is measured with:
 Xtal1 = Vss, Xtal2 = N.C., Reset = Vss, all other pins are disconnected.

Specifications of HMS91C7432

AC ELECTRICAL CHARACTERISTICS

($T_a = -20^{\circ}\text{C}$ To $+85^{\circ}\text{C}$, $V_{cc} = 5.0\text{V} + 10\%$, $3.3\text{V} + 10\%$, $V_{ss} = 0\text{V}$)

EXTERNAL CLOCK DRIVE

Symbol	Parameter	5.0V +/- 10%		3.3V +/- 10%		Unit
		Min	Max	Min	Max	
$1/t_{CLCL}$	Osc. Freq.	3.5	25	3.5	20	MHz
t_{CHCX}	High Time	20		15		ns
t_{CLCX}	Low Time	20		15		ns
t_{CLCH}	Rise Time		20		25	ns
t_{CHCL}	Fall Time		20		25	ns

EXTERNAL CLOCK DRIVE WAVEFORM

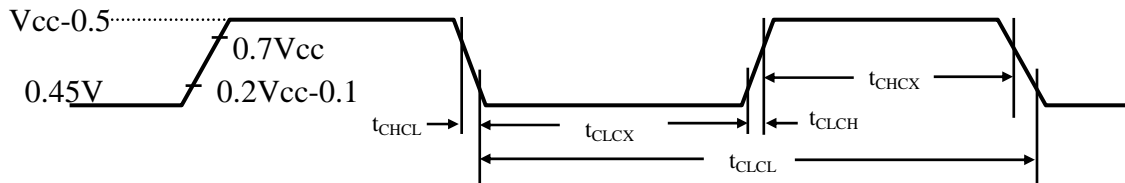

Specifications of HMS91C7432

Data format for communication between HMS91C7432 and the host MCU

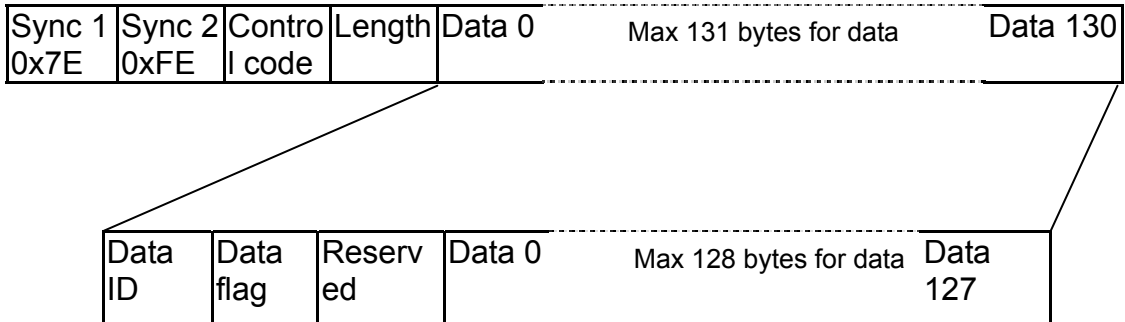

Figure 3. Data packet format

Field description :

Field	Description	Value
Sync 1	Synchronization for start of Command/Data packet.	Always set to 0x7E
Sync 2	As above	Always set to 0xFE
Control code	This is the command code field in simple command mode. Specify the "Type of command" in complex command mode.	In simple command mode 0x80 ~ 0x89. In complex command mode 0x00 ~ 0x06 Refer to table 3
Length	Specify the length of the Data field.	0 ~ 131
Data fields	Max. length of 131 octets for each packet containing structures for complex command data; setup parameters; response code and mail text contents in various communication mode accordingly.	Refer to the explanation of the communication mode.
Data ID	Specify the types of data containing in the current packet.	0x00 ~ 0x34 refer to the table 4
Data Flag	Specify whether the current packet is the last packet or more packet follow.	0x00 more packet follow 0x01 last packet
Reserved	Reserved for test purpose. Disregard this field in normal operation.	Not applicable
Data 0 ~ 127	Contain max 128 octets of data	Single byte data

Table 2. Field descriptions for communication packet

Specifications of HMS91C7432

Table 3. Listing of Control Code

Control Code	Description	Direction
0x00	Use this control code for complex command mode and mail text transfer. This is a bi-directional command code. HMS91C7432 uses this code to pass mail's information and mail's body to the host.	Bi-directional depending on the Data ID
0x01	For HMS91C7432 to issue complex command to the host to request for Line Connection Info (refer to Table 5 for Info Listing).	HMS91C7432 To Host
0x02	For HMS91C7432 to issue Result Code to the host (refer to Table 6 for Result Code Listing).	HMS91C7432 To Host
0x03	For HMS91C7432 to issue the Connection Status to the host (refer to Table 7 for Connection Status Listing). The issuance of the Connection Status is in respond to the Host's request using Control Code 0x04 in the complex command mode.	HMS91C7432 To Host
0x04	Host use this control code to request the report for Connection Status. This code is to be used in Simple Command mode.	Host to HMS91C7432
0x05	Host use this control code to request the report for SMTP Processing Status. This code is to be used in Simple Command Mode.	Host to HMS91C7432
0x06	For HMS91C7432 to issue the SMTP Processing Status (refer to Table 8 for the SMTP Status Listing). The issuance of the SMTP Processing Status is in respond to the Host's request using Control Code 0x05 in the complex command mode.	HMS91C7432 To Host
0x80	Initiate Modem – host's command in Simple Command mode. Instruct the HMS91C7432 to initialize the Modem and send the pre-set AT initializing string. This command must be issued after the AT initializing string has been passed.	Host to HMS91C7432
0x81	Terminate – host's command in Simple Command mode. Instruct the HMS91C7432 to terminate the current process.	Host to HMS91C7432
0x82	Log In ISP – host's command in Simple Command mode. Instruct the HMS91C7432 to Login to the ISP. When the command is accepted, HMS91C7432 will run the login process automatically and report to the host by using Control Code 0x02 complex command. The whole login process consists of the following steps, and Connection Status will be reported on each step. <ul style="list-style-type: none"> 1. Modem off hook 2. Dial up ISP 3. Modem handshake 4. Logon and authentication check using PPP The Login process ends when the authentication check is passed or in any cases a connection failure occurs. This command must be issued after the Login information have been passed, otherwise, HMS91C7432 will issue request using Control Code 0x01 for missing info.	Host to HMS91C7432

Specifications of HMS91C7432

Continue of Table 3. Listing of Control Code

0x83	<p>Quit ISP – Host’s command in Simple Command mode. Instruct the HMS91C7432 to end the current ISP session. When the command is accepted, HMS91C7432 will run the Disconnect process automatically and report to the host by using Control Code 0x02 complex command. The whole Disconnect process consists of the following steps, and Connection Status will be reported on each step.</p> <ol style="list-style-type: none"> 1. Quit the ISP internet connection 2. Disconnect the telephone line 3. Hang up the modem and modem go On Hook <p>The Quit process ends when the modem responds with On Hook OK, or in any cases a connection failure occurs.</p>	Host to HMS91C7432
0x84	<p>Login SMTP Server - Host’s command in Simple Command mode. Instruct the HMS91C7432 to login to the dedicated SMTP server. Upon the command is accepted, HMS91C7432 will run the following steps, and Connection Status will be reported on each step.</p> <ol style="list-style-type: none"> 1. Run DNS protocol to resolve for the SMTP server’s IP address. 2. Register to the SMTP server. <p>The Login SMTP process ends when the SMTP server returns an OK response code, or in any cases a Logon failure occurs.</p>	Host to HMS91C7432
0x85	<p>Quit SMTP Server - Host’s command in Simple Command mode. Instruct the HMS91C7432 to end the current SMTP session. Upon the command is accepted, HMS91C7432 will quit the SMTP Server and keep ON LINE (keep connection with the internet). Quit SMTP OK will be reported to the host by using Control Code 0x02 complex command.</p>	Host to HMS91C7432
0x86	<p>Send Mail Request - Host’s command in Simple Command mode. Instruct the HMS91C7432 to get permission from the SMTP server for sending mail. Upon the command is accepted, HMS91C7432 will run the following steps, and Connection Status will be reported on each step.</p> <ol style="list-style-type: none"> 1. Send the “Send Mail” request to the SMTP server 2. Pass Sender email address; Recipient email address to the SMTP server for validation. 3. Wait for permission to send the mail’s body. <p>When the SMTP server accept all the mail info and an OK to send is received, HMS91C7432 will issue Ready to send response using Control Code 0x02 to the host. DO NOT send the mail body before this response is issued.</p>	Host to HMS91C7432

Specifications of HMS91C7432

Continue of Table 3. Listing of Control Code

0x87	<p>Login POP3 server - Host's command in Simple Command mode. Instruct the HMS91C7432 to login to the dedicated POP3 server. Upon the command is accepted, HMS91C7432 will run the following steps, and Connection Status will be reported on each step.</p> <ol style="list-style-type: none"> 1. Run DNS protocol to resolve for the POP3 server's IP address. 2. Register to the POP3 server and run the authentication check process 3. If authentication check is passed, request the POP3 server to return the number of mail contain in the mailbox. 4. If UIDL option is set (refer to Table 4 for explanation of UIDL option), request the POP3 server to return the Length and UID for each mail in the mailbox. <p>The Login POP3 process ends when the POP3 server returns the number of mail and or the UIDL, or in any cases a Logon failure occurs. Upon receipt of the "Number of Mail" info and the UIDL info, HMS91C7432 will pass these info to the host by using Complex Command mode with Control Code 0x00.</p> <p>The Login POP3 command must be issued after the POP3 Login information have been passed, otherwise, HMS91C7432 will issue request using Control Code 0x01 for missing info.</p>	Host to HMS91C7432
0x88	<p>Quit POP3 Server - Host's command in Simple Command mode. Instruct the HMS91C7432 to end the current POP3 session. Upon the command is accepted, HMS91C7432 will quit the POP3 Server and keep ON LINE (keep connection with the internet). Quit POP3 OK will be reported to the host by using Control Code 0x02 complex command.</p>	Host to HMS91C7432
0x89	<p>Shut Down HMS91C7432 - Host's command in Simple Command mode. Instruct the HMS91C7432 to enter the Power Down mode. Make sure the SMTP session or the POP3 session is terminated and the line is disconnected before the Shut Down command is issued.</p>	Host to HMS91C7432

Specifications of HMS91C7432

Table 4. Listing of Data ID

Data ID	Description	Command mode
0x00	Baud rate for HMS91C7432 serial UART port setting.	Host command
0x01	Modem AT initialize string	""
0x02	Modem Result Code listing	""
0x03	HMS91C7432 clock selection	""
0x04	POP3 UIDL return option	""
0x05~0x20	Reserved by the system. Do Not Use.	""
0x21	Telephone Number for dialup network.	""
0x22	User ID for the dialup network account	""
0x23	Password for the dialup network account	""
0x24	IP address for the DNS server (if not specified, dynamic DNS server search will be used).	""
0x25	SMTP port (if not specified, use default value port 25)	""
0x26	POP3 port (if not specified, use default value port 110)	""
0x27	SMTP server domain name	""
0x28	POP3 server domain name	""
0x29	User ID for POP3 account	""
0x2A	Password for POP3 account	""
0x2B	Sender's email address	""
0x2C	Recipient's email address	""
0x2D	Mail text body	Host command / HMS91C7432 data returns
0x2E	Reserved	N.A
0x2F	Reserved	N.A.
0x30	Number of mail in POP3 server	HMS91C7432 returns
0x31	UID listing	HMS91C7432 returns
0x32	Get Mail (followed with the mail number)	Host command
0x33	Delete Mail from server (followed with the mail number)	Host command
0x34	Get UID for a particular mail on the server (followed with the mail number)	Host command

Specifications of HMS91C7432

Table 5. Listing of Info code for complex request mode made by HMS91C7432

Data ID	Description
Data_ID.0	Requesting Recipient's and Sender's email address
Data_ID.1	Requesting Password for POP3 account
Data_ID.2	Requesting User ID for POP3 account
Data_ID.3	Requesting Domain Name for POP3 server
Data_ID.4	Requesting Domain Name for SMTP server
Data_ID.5	Requesting Password for dialup network account
Data_ID.6	Requesting User ID for dialup network account
Data_ID.7	Requesting Telephone number for dialup account

Note on use: Whenever the HMS91C7432 needs network connection info, and it is missing or corrupted in HMS91C7432 memory, HMS91C7432 will issue a request using complex command mode with Control Code 0x01 following with the above Data ID for necessary information return. Each bit of the Data ID, if set, indicates the co-responding info is needed.

Table 6. Listing of Response Code issued by HMS91C7432

In respond to the host's command, the HMS91C7432 always return the following Response Code by using complex command mode with Control Code 0x02. The time taking to a response is variable and mostly depending on the physical connection and the network traffic. Make sure a response code is received before issuing a new command.

Response Code	Description	Related layer and protocol
0x40	Modem is ready	Modem initialization
0x41	Connected – modem is connected to the remote terminal	Modem Dialup
0x42	Modem not ready – modem is not presented or modem does not return a correct response	Modem initialization
0x43	No Carrier – No carrier signal is detected. Modem will hang up automatically.	Modem Dialup
0x44	Error – Modem internal error or unknown modem error.	Modem Dialup
0x45	No Dial tone – No dial tone is detected. Possibly the phone line is not connected.	Modem Dialup
0x46	Busy – Line is busy.	Modem Dialup
0x47	No answer – phone is no answer	Modem Dialup
0x48	Modem Hang Up – The modem is disconnected.	Modem Dialup
0x49	Internet Logon OK – The internet account authentication is passed, Logon success.	PPP

Specifications of HMS91C7432

Continue to Table 6. Listing of Response Code issued by HMS91C7432

0x4A	ISP No Response – ISP has no response after a long time out.	PPP
0x4B	Authentication Fail – Invalid User ID or invalid password	PPP
0x4C	Logon Fail – Unable to logon to the internet for other reason	PPP
0x4D	Internet Quit OK – Disconnect from the internet and go Off Line.	PPP
0x4E	Reserved	
0x4F	Reserved	
0x50	Mail Sent OK – a mail is sent successfully	SMTP
0x51	SMTP Logon Fail – Fail to logon to the SMTP server	SMTP
0x52	Mail Received OK – A mail is received successfully	POP3
0x53	POP3 Logon Fail – Fail to logon to the POP3 server	POP3
0x54	POP3 Authentication Fail – Invalid POP3 User ID or invalid POP3 password	POP3
0x55	Transmission Data Error – Data passed to the server is not accepted (e.g. un-resolvable email address)	SMTP
0x56	Reception Data Error – Invalid data is received.	POP3
0x57	NO New Mail – POP3 mail box is empty	POP3
0x58	SMTP Logon OK – Successfully Logon to the SMTP server	SMTP
0x59	POP3 Logon OK – Successfully Logon to the POP3 server	POP3
0x5A	DNS Fail – Unable to locate DNS server or DNS server return invalid data	DNS
0x5B	SMTP Quit – Exit SMTP server	SMTP
0x5C	POP3 Quit – Exit POP3 server	POP3
0x5D	Mail Deleted – A mail is deleted from the POP3 mail box	POP3
0x5E	Mail Deleted Fail – Unable to delete the mail, either the mail number is not exist or the mail is locked by the server	POP3
0x5F	Wrong Mail Number – The mail number not exist in the mailbox.	POP3
0x60	SMTP Ready to Send – HMS91C7432 is ready to accept next packet of the mail text body.	SMTP
0x61	SMTP Buffer Overflow – HMS91C7432 outgoing buffer is full. Last packet received is invalid. Host must resend the previous packet.	SMTP
0x62	SMTP Buffer full – HMS91C7432 outgoing buffer is nearly full and can not accept more data. The last packet is accepted.	SMTP

Specifications of HMS91C7432

Table 7. List of Response Code for Network Status

Upon receipt of a "Network Status Request" issued by the host with Control Code 0x04, the HMS91C7432 respond the request by returning the following code using complex command mode with Control Code 0x03.

Response Code	Mnemonics	Descriptions
0x00	Wait	Network is on hold or in processing, waiting for the network to return instruction or data.
0x01	Dialing	HMS91C7432 is connecting the internet service.
0x02	Logon ISP in progress	Passing Logon info and authentication check in progress
0x03	Logon ISP OK	System is On Line and the network is connected.
0x04	Logon SMTP in progress	Resolving SMTP IP address and waiting for SMTP server to respond.
0x05	Logon SMTP OK	System has logon to the SMTP server. Ready to send mail (send the mail header for validation first).
0x06	Mail Header is accepted	SMTP server has validated the addresses
0x07	Sending Mail	Sending Mail in progress
0x08	Quitting SMTP server	Quit command has been issued to the SMTP server, waiting for response.
0x09	Logon POP3 in progress	Resolving POP3 server's IP address and waiting for the result of the authentication check.
0x0A	Logon POP3 Ok	System has logon to the POP3 server.
0x0B	Getting Uid	Waiting for return of Unique ID of a mail.
0x0C	Requesting Mail	Mail request was sent, waiting for server to return mail.
0x0D	Retrieving Mail	Mail reception in progress.
0x0E	Deleting Mail	Delete Mail request was sent, waiting for server to return result.
0x0F	Quitting POP3 server	Quit command has been issued to the POP3 server, waiting for response.
0x10	Network disconnecting	Quit command has been issued to the ISP, waiting for server to respond.
0x11	Modem disconnecting	Hanging up the modem and waiting for the modem to respond.

Specifications of HMS91C7432

Table 8. List of SMTP status response

HMS91C7432 return the following response code when the host makes a request by using simple command mode with control code 0x05.
HMS91C7432 return the response by using complex command mode with control code 0x06.

Response code	Mnemonics	Description
0x60	SMTP Ready to Send	HMS91C7432 is ready to accept next packet of the mail text body.
0x61	SMTP Buffer Overflow	HMS91C7432 outgoing buffer is full. Last packet received is invalid. Host must resend the previous packet.
0x62	SMTP Buffer full	HMS91C7432 outgoing buffer is nearly full and can not accept more data. The last packet is accepted.

Examples of inter-chip communication session:

Example 1. Commands issued by the host using Simple Command Mode

Sync 1	Sync 2	Control code	Length
0x7E	0xFE	0x80 ~ 0x89	0x00

The following command string instructs the HMS91C7432 to logon to the ISP

0x7E	0xFE	0x82	0x00
------	------	------	------

Example 2. Command issued by the host that using Complex Command Mode

Sync 1	Sync 2	Control	Length	Data ID	Data Flag	Reserved	Data 0	Data 127
0x7E	0xFE	0x00	Value	0 ~ 34h	0 or 1	NA		

The following command string instructs the HMS91C7432 to retrieve a the mail #2 from the POP3 server. Note that the Mail number must be defined as an integer (2 bytes long).

Sync 1	Sync 2	Control	Length	Data ID	Data Flag	Reserved	Data 0	Data 1
0x7E	0xFE	0x00	0x05	0x32	0x01	0x00	0x00	0x02

Example 3. A packet of mail text body received from HMS91C7432

This packet is passed from the HMS91C7432 in Complex Data Mode, Data ID 0x2D indicate that the packet contain portion of a mail body. Data Flag is '0' indicates that more packet will follow. Length is '0x83' indicates that there are 131 bytes after the length field. The actual text data occupy 128 bytes only. Use the same format to pass outgoing mail body to the HMS91C7432.

Sync 1	Sync 2	Control	Length	Data ID	Data Flag	Reserved	Data 0	Data 1	Data 127
0x7E	0xFE	0x00	0x83	0x2D	0	0	T	e	Ascii	x

Specifications of HMS91C7432

Example 4. HMS91C7432 request for missing connection info

When the HMS91C7432 is going to make a connection to the internet or to a mail server, it will check if all necessary info is available. The connection info may be erased due to memory overlaying. Upon an internet session is ended, HMS91C7432 will clear its memory pool for another session. Whenever connection info is needed, HMS91C7432 will issue a request to the host for such info. The request will be made using complex command mode with control code 0x01 followed by a Data ID as listed in Table 5.

Sync 1	Sync 2	Control	Length	Data ID
0x7E	0xFE	0x01	0x01	0x08

This example demonstrates a request made by the HMS91C7432 for the POP3 server's domain name when it is going to logon to the POP3 server.

Example 5. HMS91C7432 returning result code to the host

There are sets of Result Code corresponding to each command issued by the host to the HMS91C7432. The HMS91C7432 returns at least one result code to each command, to report the result of execution or the status of the connection. HMS91C7432 returns the result code by using complex command mode with control code 0x02 followed by the result code (in the Data ID field) as listed in Table 6.

Sync 1	Sync 2	Control	Length	Data ID
0x7E	0xFE	0x02	0x01	0x49

This example demonstrates a result code returned from HMS91C7432 to report that the authentication check is passed and the system is ON LINE (Logon to the ISP is success).

Example 6. Host requesting Connection Status and the HMS91C7432 returns

User may make a request for the connection status at any time during the internet session. The host may make its request by using Simple Command Mode with Control Code 0x04. The HMS91C7432 will return the connection status by Complex Command Mode with Control Code 0x03 followed by the connection status code as listed in Table 7.

This example demonstrates how the host makes a connection status request and how the HMS91C7432 responds to this request. The host made the request after a successful logon to the POP3 server. The HMS91C7432 report that the system has logon to the POP3 server.

Host requesting command format:

Sync 1	Sync 2	Control	Length
0x7E	0xFE	0x04	0x00

HMS91C7432 return the connection status:

Sync 1	Sync 2	Control	Length	Data ID
0x7E	0xFE	0x03	0x01	0x0A

Specifications of HMS91C7432

Example 7. Host requesting SMTP Connection Status and the HMS91C7432 returns

When sending out an email during SMTP session, the host should know when can it pass the mail header and when can it pass the mail body to the HMS91C7432. Usually, depending on the traffic of the network, it takes a longer time to be successfully logon to the SMTP server. The host should frequently check the connection status to determine the time to pass the mail header or to determine when to terminate the logon process if a time out is up. The host may make such a report by using Simple Command Mode with Control Code 0x05. The HMS91C7432 will return the SMTP connection status by Complex Command Mode with Control Code 0x06 followed with the SMTP status code as listed in Table 8.

This example demonstrates how the host makes a SMTP connection status request and how the HMS91C7432 responds to this request. The host made the request after a successful logon to the SMTP server. The HMS91C7432 report that it is ready to accept the mail body. If the request is made during the mail sending session, the following connection status indicates the HMS91C7432 is ready to accept more packets (Outgoing buffer is not full).

Host requesting command format:

Sync 1	Sync 2	Control	Length
0x7E	0xFE	0x05	0x00

HMS91C7432 return the connection status:

Sync 1	Sync 2	Control	Length	Data ID
0x7E	0xFE	0x06	0x01	0x60

Specifications of HMS91C7432

Plastic Package P-DIP-20 (Plastic Dual In Package)

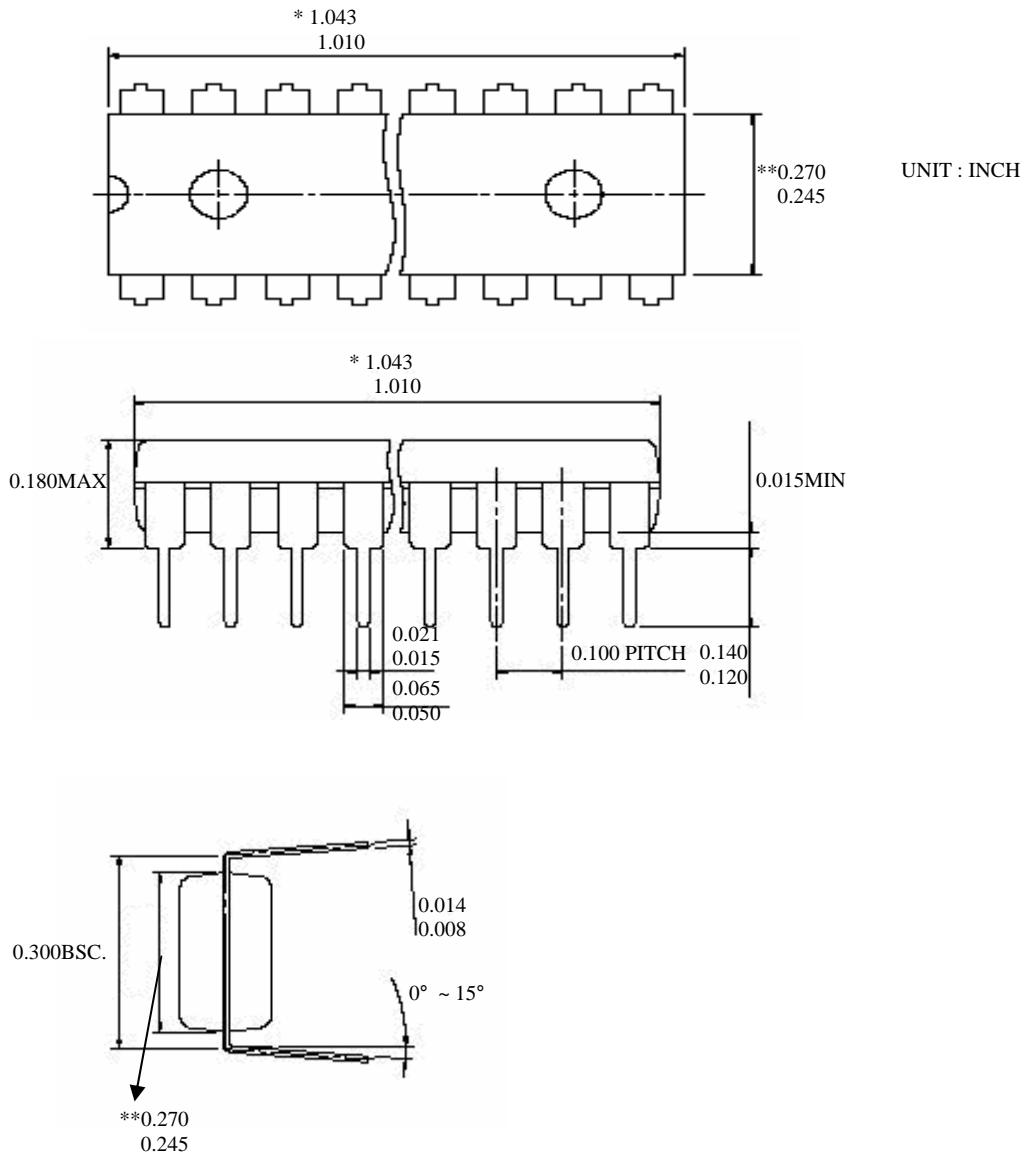

- NOTE -

1. DIMENSION * MARK DOES NOT INCLUDE MOLD PROTRUSION
MAXIMUM ALLOWABLE PROTRUSION IS 0.010 INCH PER SIDE.
2. DIMENSION ** MARK DOES NOT INCLUDE MOLD PROTRUSION
MAXIMUM ALLOWABLE PROTRUSION IS 0.010 INCH PER SIDE.
- ~~3. UNSPECIFIED IS ACCORDING TO JEDEC MS-001 VARIATION AE.~~

Specifications of HMS91C7432

Plastic Package P-SOP-20

(Plastic Small Outline Package)

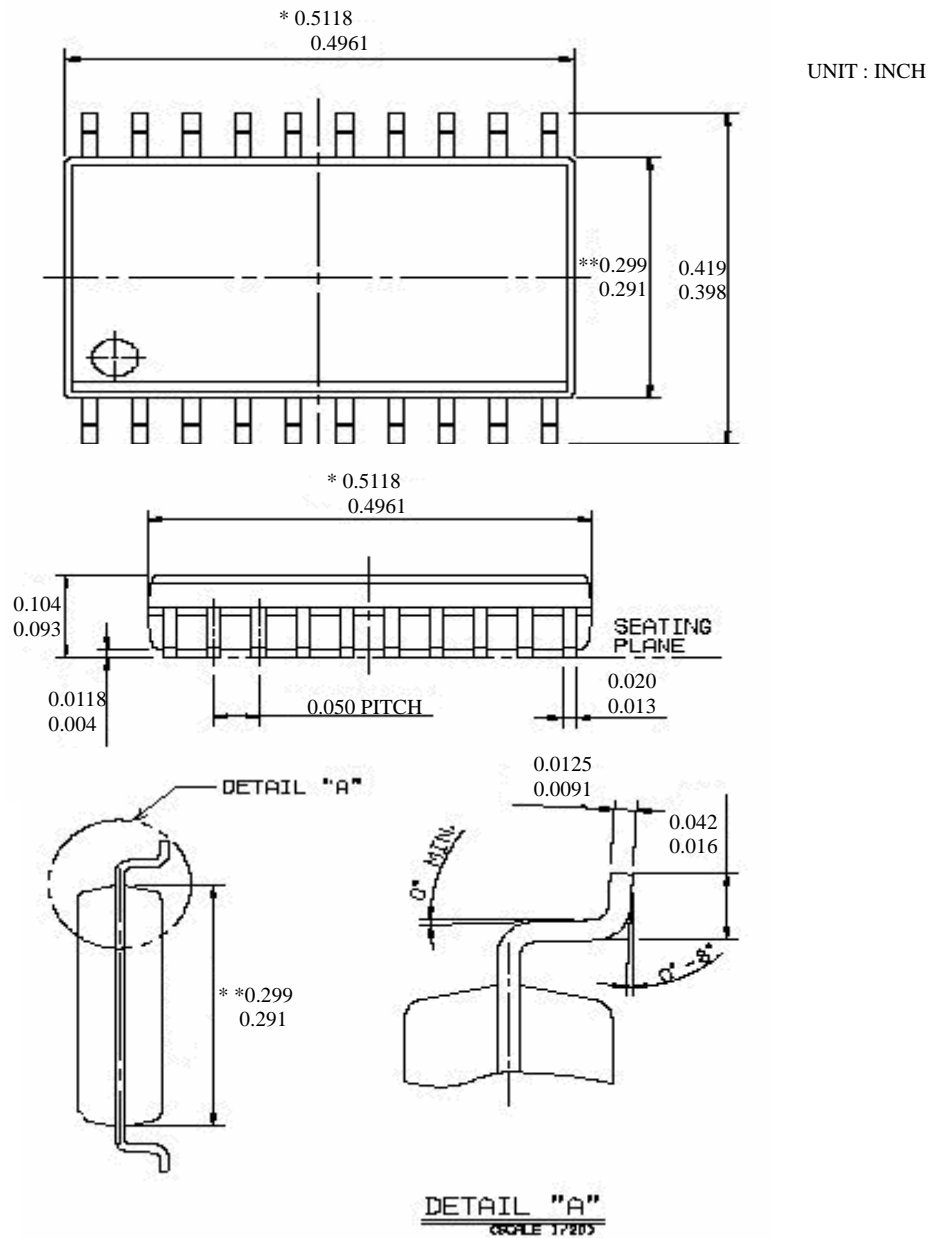

- NOTE -

1. DIMENSION * MARK DOES NOT INCLUDE MOLD PROTRUSION
MAXIMUM ALLOWABLE PROTRUSION IS 0.006 INCH PER SIDE.
2. DIMENSION ** MARK DOES NOT INCLUDE MOLD PROTRUSION
MAXIMUM ALLOWABLE PROTRUSION IS 0.010 INCH PER SIDE.
3. DIMENSIONING AND TOLERANCING PER ANSI Y14.5M-1982

4. UNSPECIFIED IS ACCORDING TO JEDEC MS-013, VARIATION "AC"

Preliminary

Application examples

