

NE5520 LVDT Signal Conditioner

Product Specification

Linear Products

DESCRIPTION

The NE5520 is a signal conditioning circuit for use with Linear Variable Differential Transformers (LVDT). The chip includes a low distortion amplitude stable sine wave oscillator with programmable frequency to drive the primary of the LVDT; a synchronous demodulator to convert the LVDT output amplitude and phase to position information; and an output amp to provide gain and filtering.

FEATURES

- Oscillator frequency: 1kHz to 20kHz
- Low distortion
- Capable of ratiometric operation
- Single supply operation 5V to 20V or dual supply $\pm 2.5V$ to $\pm 10V$
- Low power consumption

APPLICATIONS

- LVDT signal conditioning
- RVDT signal conditioning

ORDERING INFORMATION

DESCRIPTION	TEMPERATURE RANGE	ORDER CODE
14-Pin Plastic DIP	0 to +70°C	NE5520N
16-Pin SOL Package	0 to +70°C	NE5520D
16-Pin Ceramic DIP	0 to +70°C	NE5520F

ABSOLUTE MAXIMUM RATINGS

SYMBOL	PARAMETER	RATING	UNIT
V_S	Supply voltage	+20	V
	Split supply voltage	± 10	V
T_A	Operating temperature range	0 to +70	°C
T_{STG}	Storage temperature range	-65 to +165	°C
P_D	Power Dissipation ¹	840	mW

NOTES:

1. Supplied only in large SO (Small Outline) package. See package diagram.
2. Pin numbers are for N package.

PIN CONFIGURATIONS

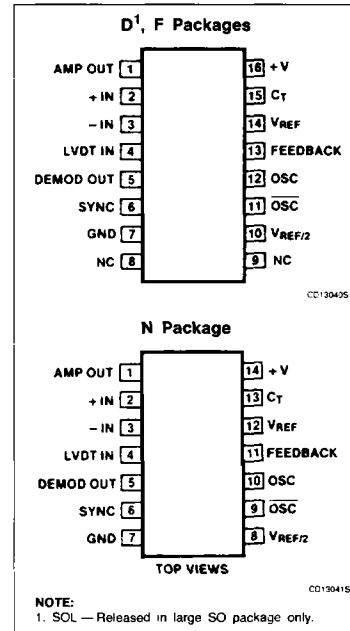

LVDT Signal Conditioner

NE5520

BLOCK DIAGRAM

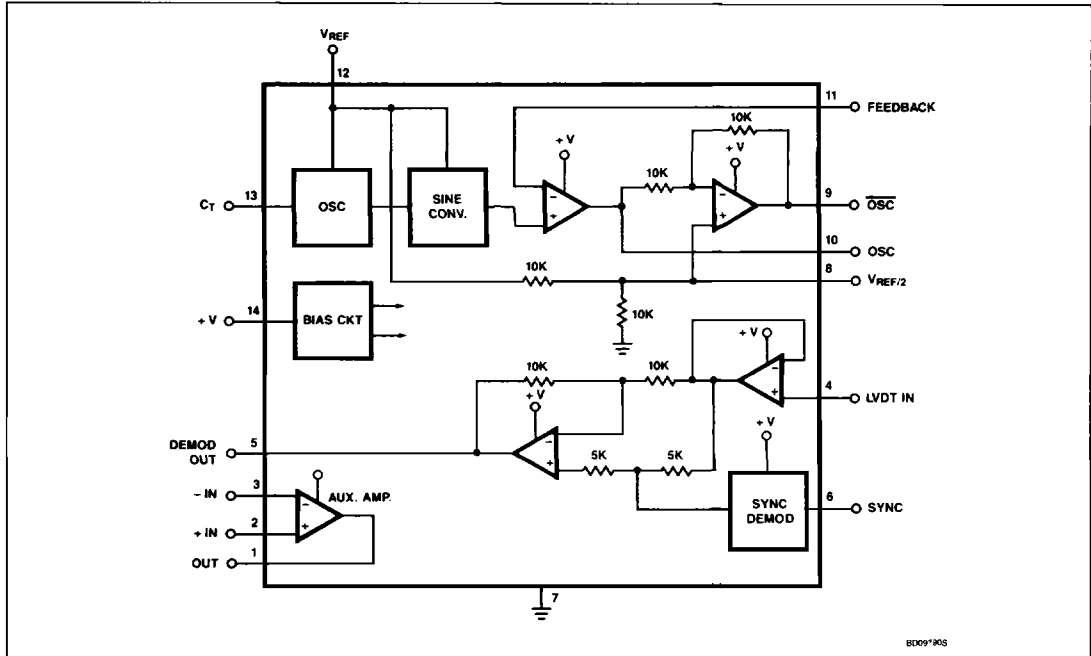

5

LVDT Signal Conditioner

NE5520

DC ELECTRICAL CHARACTERISTICS $T_A = 25^\circ\text{C}$, $V_R = V_+ = 10\text{V}$, unless otherwise specified.

SYMBOL	PARAMETER	TEST CONDITIONS	LIMITS			UNIT
			Min	Typ	Max	
I_{CC}	Supply current	Over temperature		7.0	10	mA
I_{REF}	Reference current	Over temperature		5.5	10	mA
V_{REF}	Reference voltage range	Over temperature	5		V_+	V
P_D	Power dissipation			120	220	mW
Oscillator section						
	Oscillator output			$\frac{V_R}{8.7}$		V_{RMS}
	Sine wave distortion			4		%
	Initial amplitude error				± 3	%
	Tempco of amplitude				0.05	%/ $^\circ\text{C}$
	Voltage coefficient of amplitude error				2.5	%/V
	Initial accuracy of oscillator frequency				20	%
	Tempco of frequency error			0.05		%/ $^\circ\text{C}$
	Voltage coefficient of frequency			2.5		%/ $V(V_R)$
	Oscillator output load current	Over temperature	8	15		mA_{RMS} mA_{RMS}
Demodulator section						
E_F	Linearity error	Over temperature		0.05	0.1	%
	Maximum demodulator input	Over temperature range	$\frac{V_R}{2} - 0.5$		$\frac{V_R}{2} + 0.5$	V
	Demodulator offset voltage	Over temperature range			65	mV
	Demodulator input current	Over temperature	-1000	-300		nA
	$V_{R/2}$ accuracy	Over temperature	-3	± 0.5	+3	%
Auxiliary output amplifier						
V_{OS}	Input offset voltage	Over temperature	-10		10	mV
I_{BIAS}	Input bias current	Over temperature range	-500	-300		nA
I_{OS}	Input offset current		-100		100	nA
A_V	Gain	$R_L = 10\text{k}\Omega$ over temperature		100		V/mV
SR	Slew rate			1.5		V/ μs
GBW	Gain bandwidth	$A_V = 1$		1		MHz
V_{OUT}	Output voltage swing	$R_L = 10\text{k}\Omega$ over temperature	1.5		$V_+ - 1.5$	V
I_{SC}	Output short-circuit current			50		mA

NOTE:Rating applies to ambient temperatures up to 70°C . Above 70°C derate linearly at $7.6\text{mW}/^\circ\text{C}$ for the plastic package and $7.3\text{mW}/^\circ\text{C}$ for the cerdip package.

LVDT Signal Conditioner

NE5520

TYPICAL PERFORMANCE CHARACTERISTICS

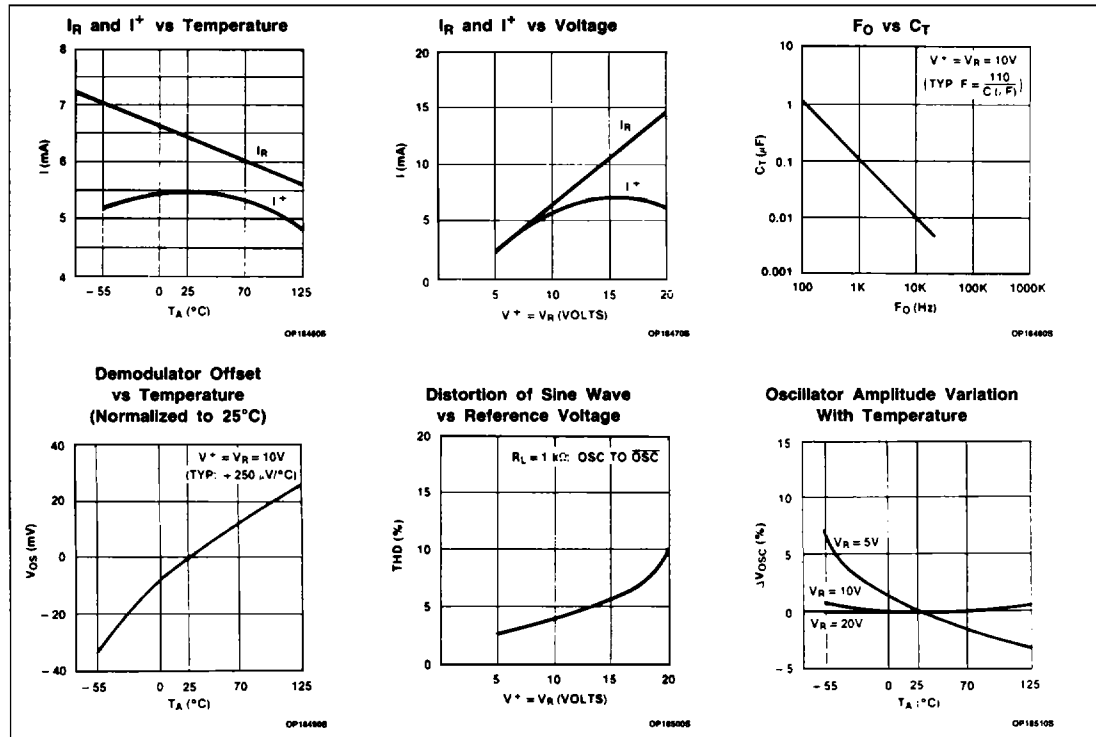

5

LVDT Signal Conditioner

NE5520

TYPICAL SINGLE SUPPLY LVDT CIRCUIT

