

**UltraCMOS™ Low Frequency Passive Mixer with Integrated LO Amplifier**

**Features**

- Ultra-high linearity Quad MOSFET array with integrated LO amplifier
- Ideal for mobile radio and Up/down conversion applications
- Low conversion loss
- High LO Isolation
- Packaged in small 20-lead 4x4 mm QFN

**Product Description**

The PE4150 is an ultra-high linearity Quad MOSFET mixer with an integrated LO amplifier. The LO amplifier allows for LO drive levels of less than 0dBm to produce IIP3 values similar to a Quad MOSFET Array driven with a 15dBm LO drive. The PE4150 operates with differential signals at the RF and IF ports and the integrated LO buffer amplifier drives the mixer core. It can be used as an upconverter or a downconverter.

The PE4150 is manufactured on Peregrine's UltraCMOS™ process, a patented variation of silicon-on-insulator (SOI) technology on a sapphire substrate, offering the performance of GaAs with the economy and integration of conventional CMOS.

**Figure 1. Functional Diagram**

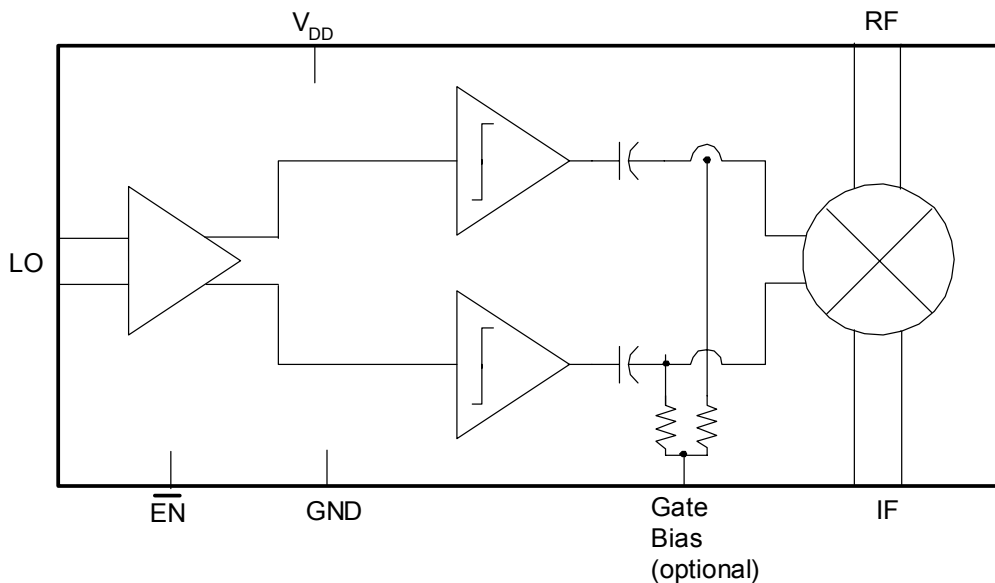

**Figure 2. Package Type**

4x4 mm 20-Lead QFN



**Table 1. AC and DC Electrical Specifications** ( $V_{DD} = 2.9$  to  $3.1$  V, Temperature =  $-40$  to  $+85$  °C unless specified otherwise)

Parameters	Min	Typ	Max	Units
Current Drain (a function of frequency)		8	12	mA
Off state leakage current			20	uA
RF Input Frequency				
VHF Band	136		174	MHz
UHF1 Band	380		470	MHz
UHF2 Band	450		520	MHz
700 MHz	764		776	MHz
800 MHz	851		870	MHz
900 MHz	935		941	MHz
LO Frequency				
VHF Band	245.65		283.65	MHz
UHF1 Band	270.35		360.35	MHz
UHF2 Band	340.35		410.35	MHz
700 MHz	873.65		885.65	MHz
800 MHz	741.35		760.35	MHz
900 MHz	825.35		831.35	MHz
IF Output Frequency	44.85		109.65	MHz
LO Input Power	-10		-6	dBm
RF Input Power			2	dBm
Conversion Loss				
VHF, UHF1, UHF2		6.5	8	dB
700, 800, and 900 MHz		7.5	8.7	dB
3 <sup>rd</sup> Order Input Intercept (IIP3) <sup>2</sup>	20	25		dBm
2 <sup>nd</sup> Order Input Intercept (IIP2)				
VHF, UHF1, UHF2	41	60		dBm
700, 800 and 900 MHz	35	50		dBm
RF to IF Isolation <sup>1</sup>				
VHF, UHF1, UHF2	35	50		dB
700, 800 and 900 MHz	25	45		dB
LO to IF Isolation	20	30		dB
LO to RF Isolation	25	30		dB

- Notes: 1. The RF to IF Isolation is measured with an input frequency equal with IF.  
2. IIP3 is measured with two tones at 0dBm, 100kHz spacing

Figure 3. Pin Configuration (Top View)

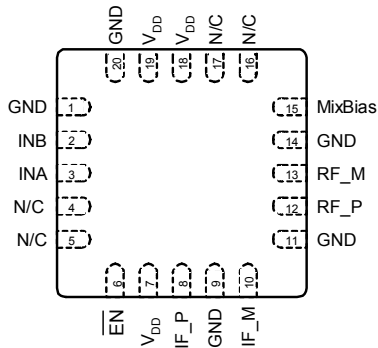

Table 2. Pin Descriptions

Pin #	Symbol	Function
1	GND	Ground
2	INB	Negative LO Input
3	INA	Positive LO Input
4	N/C	No Connect
5	N/C	No Connect
6	EN	Enable Pin (active low)
7	V <sub>DD</sub>	V <sub>DD</sub>
8	IF_P	Positive IF port
9	GND	Ground
10	IF_M	Negative IF port
11	GND	Ground
12	RF_P	Positive RF Input
13	RF_M	Negative LO Input
14	GND	Ground
15	MixBias	External Mixer Bias
16	N/C	No Connect
17	N/C	No Connect
18	V <sub>DD</sub>	V <sub>DD</sub>
19	V <sub>DD</sub>	V <sub>DD</sub>
20	GND	Ground

The RF and IF pins are differential signals connected directly to the passive mixer. The LO input can be differential or single-ended.

Table 3. Operating Ranges

Symbol	Parameters/Conditions	Min	Typ	Max	Units
V <sub>DD</sub>	V <sub>DD</sub> Power Supply Voltage	2.9	3.0	3.1	V
T <sub>OP</sub>	Operating temperature range	-40		85	°C

### Moisture Sensitivity Level

The Moisture Sensitivity Level rating for the PE4150 in the 20-lead 4x4 QFN package is MSL1.

Table 4. Absolute Maximum Ratings

Symbol	Parameters/Conditions	Min	Max	Units
V <sub>DD</sub>	Supply Voltage		4.0	V
V <sub>DS</sub>	Maximum DC plus peak AC across drain-source		±3.3	V
I <sub>DS-DC</sub>	Maximum DC current across drain-source		6	mA
I <sub>DS-AC</sub>	Maximum AC current across drain-source		36	mA <sub>p-p</sub>
T <sub>ST</sub>	Storage temperature range	-65	150	°C
T <sub>J</sub>	Operating Junction Temperature		125	°C
V <sub>ESD</sub>	ESD Voltage (HBM, MIL_STD 883 Method 3015.7)		1000	V

Exceeding absolute maximum ratings may cause permanent damage. Operation should be restricted to the limits in the Operating Ranges table. Operation between operating range maximum and absolute maximum for extended periods may reduce reliability.

### Electrostatic Discharge (ESD) Precautions

When handling this UltraCMOS™ device, observe the same precautions that you would use with other ESD-sensitive devices. Although this device contains circuitry to protect it from damage due to ESD, precautions should be taken to avoid exceeding the specified rating.

### Latch-Up Avoidance

Unlike conventional CMOS devices, UltraCMOS™ devices are immune to latch-up.

### Device Description

The PE4150 passive broadband Quad MOSFET array is designed for use in up-conversion and down-conversion applications for high performance systems such as mobile radios, cellular infrastructure equipment, and STB/CATV systems.

The PE4150 is an ideal mixer core for a wide range of mixer products, including module level solutions that incorporate baluns or other single-ended matching structures enabling three-port operation.

The performance level of this passive mixer is made possible by the very high linearity afforded by Peregrine's UltraCMOS™ process.

## Evaluation Kit

The Mixer Evaluation Kit board was designed to ease customer evaluation of the PE4150 Quad MOSFET Mixer with integrated LO amplifier.

The RF and IF ports are connected through 50ohm transmission lines and 1:4 transmission line transformers to J5 and J7, respectively. The LO ports are connected through 50ohm transmission lines to J4 and J6, respectively, and can support either a single-ended or differential signal drive. With a single-ended input, no termination is needed on the un-used port.

The board is constructed of a two metal layer FR4 with a total thickness of 0.062". The bottom layer provides ground for the RF transmission lines. The transmission lines were designed using a coplanar waveguide with ground plane model using a trace width of 0.037", trace gaps of 0.008", dielectric thickness of 0.059" and metal thickness of 0.0015".

J3 provides an optional external DC bias that can be applied to the LO input, if there is DC component to the applied RF input. To use this option, transformers T2 and T3 must be carefully chosen to allow the use of a non-zero common-mode level.

J9 can be used to enable or disable the part. The chip enable /EN is active low.

De-coupling capacitors are provided on the VDD traces. These capacitors should be placed as close to the DVDD pin as possible.

## Applications Support

If you have a problem with your evaluation kit or if you have applications questions, please contact applications support:

E-Mail: [help@psemi.com](mailto:help@psemi.com) (fastest response)  
Phone: (858) 731-9400

**Figure 4. Evaluation Board Layout**

Peregrine Specification 101/0201

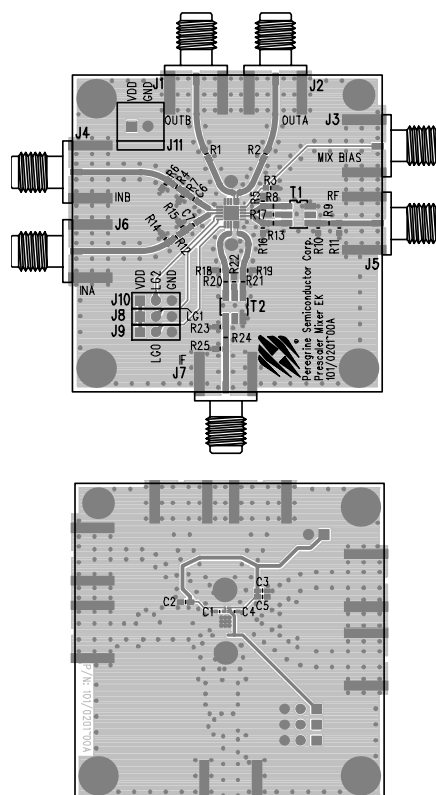

**Figure 5. Evaluation Board Schematic**

Peregrine Specification 102/0396

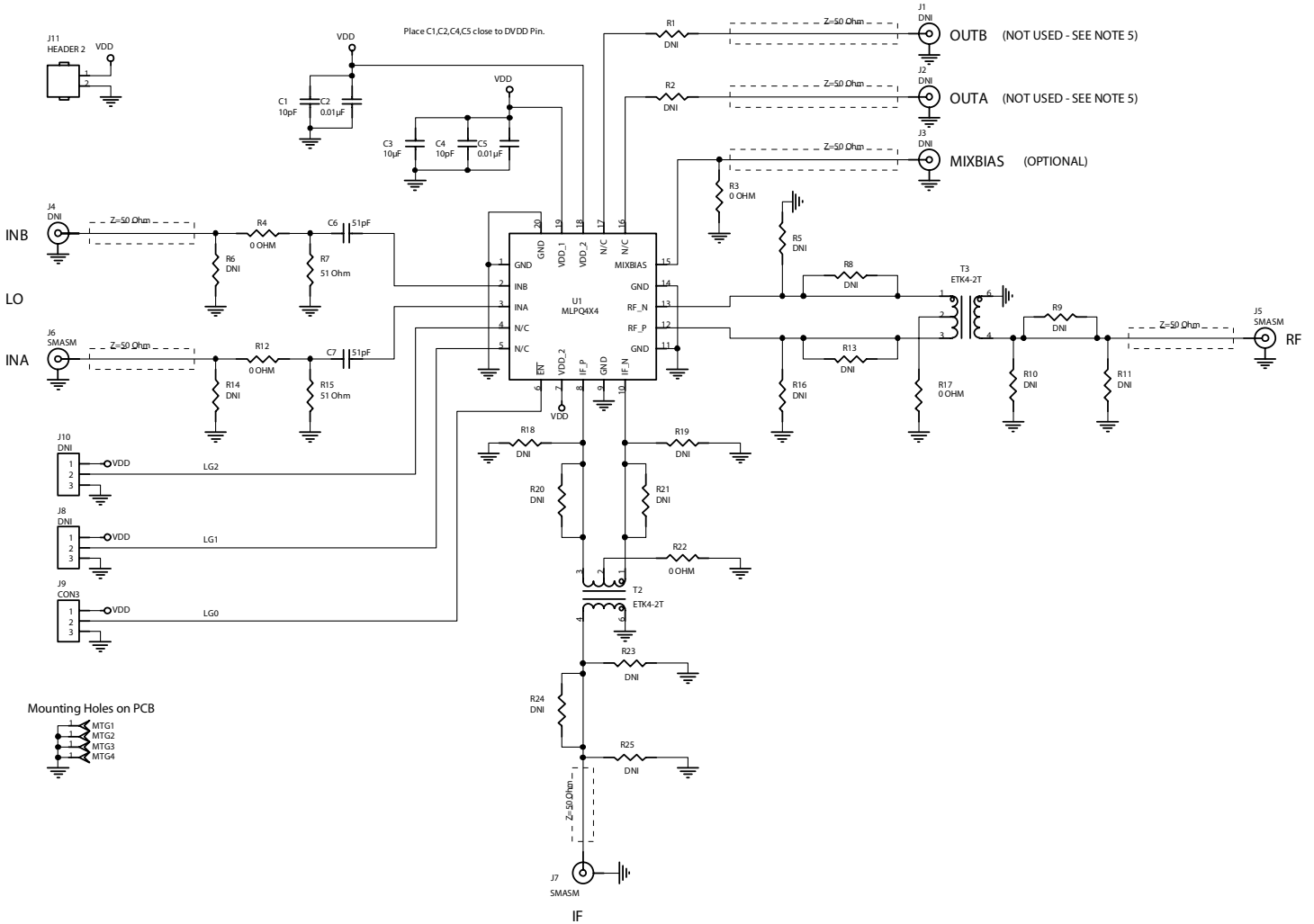

**NOTES:**

1. USE 101-0201-00A PCB.
2. CAUTION:  
CONTAINS PARTS AND ASSEMBLIES SUSCEPTIBLE TO DAMAGE BY ELECTROSTATIC DISCHARGE (ESD)
3. LO INPUT CAN BE DIFFERENTIAL OR SINGLE ENDED (INA/INB)
4. WITH SINGLE ENDED LO INPUT, NO TERMINATION IS NEEDED ON UNUSED PORT.
5. PINS 16 AND 17 ARE INTERNALLY DISCONNECTED.

Typical Performance Plots

Figure 6. Conversion Loss vs Temperature  
(VDD = 3V; LO Pwr = -10 dBm)

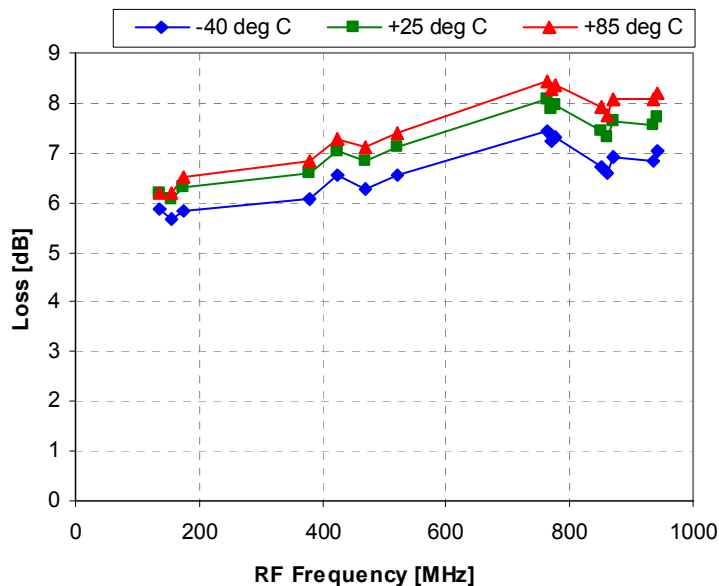

Figure 7. Conversion Loss vs LO Power & VDD  
(Temp = 25 deg C)

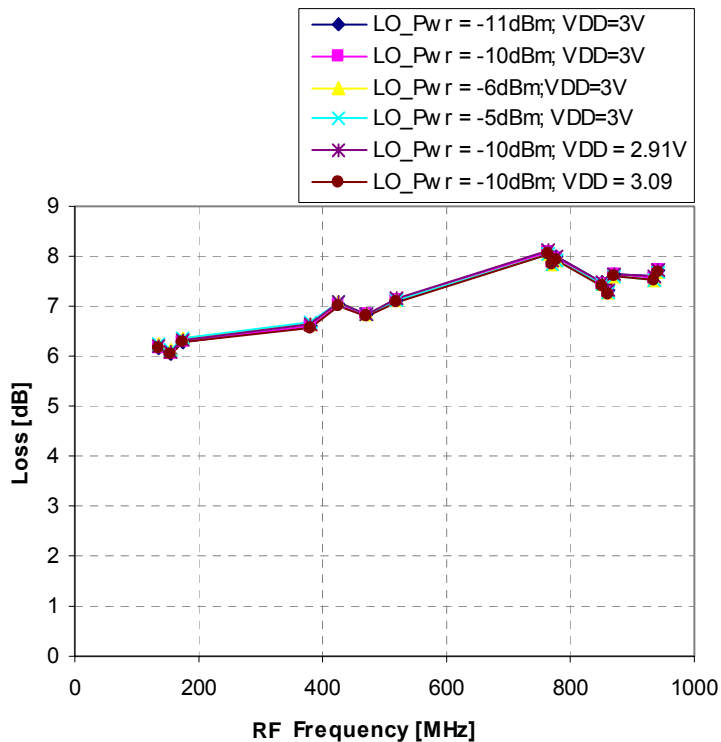

Figure 8. Linearity vs Temperature  
(VDD = 3V; LO Pwr = -10 dBm)

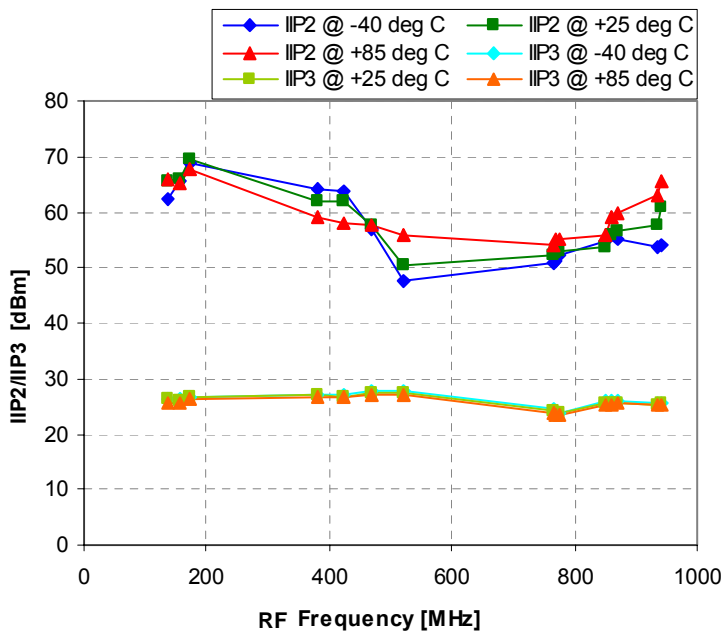
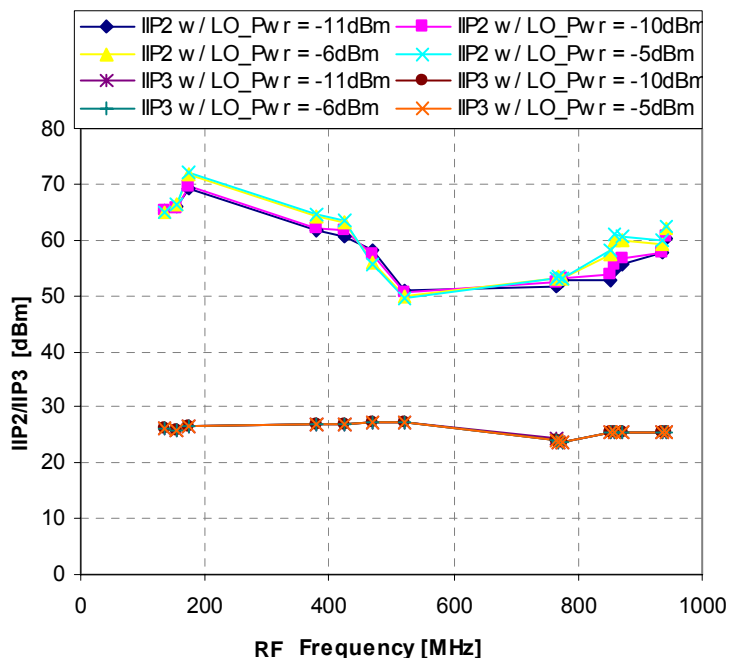

Figure 9. Linearity vs LO Power  
(VDD = 3V; Temp = +25 deg C)



Typical Performance Plots

Figure 10. Linearity vs VDD

(Temp = +25 deg C; LO Pwr = -10 dBm)

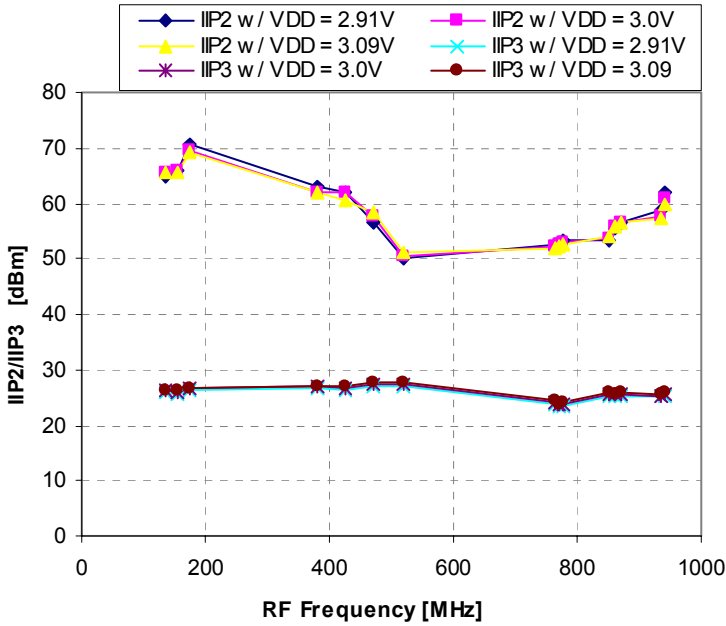

Figure 11. Isolation vs Temperature

(VDD = 3V; LO Pwr = -10 dBm)

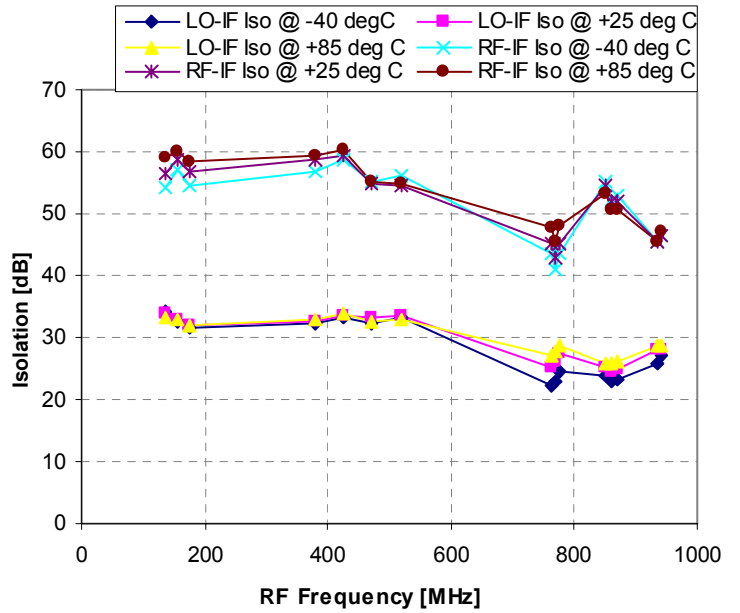

Figure 12. Isolation vs LO Power

(VDD = 3V; Temp = +25 deg C)

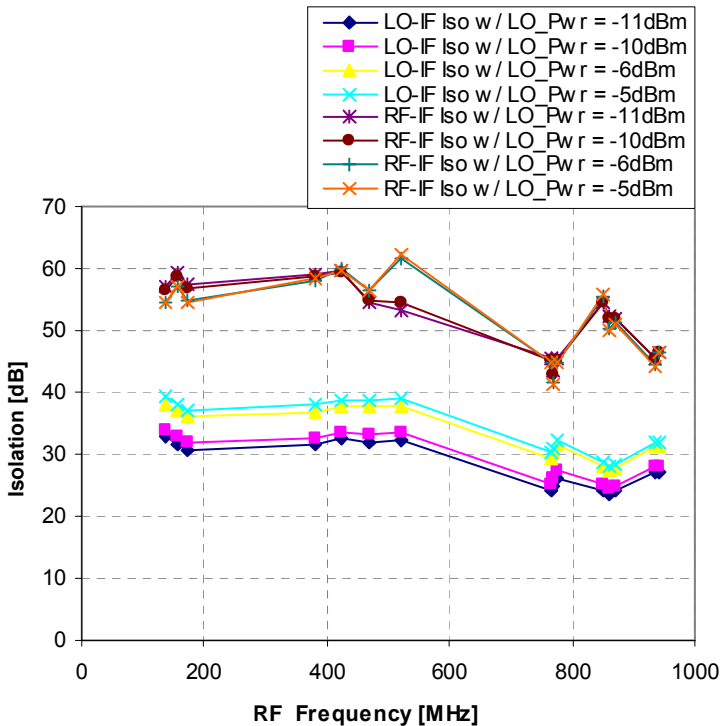
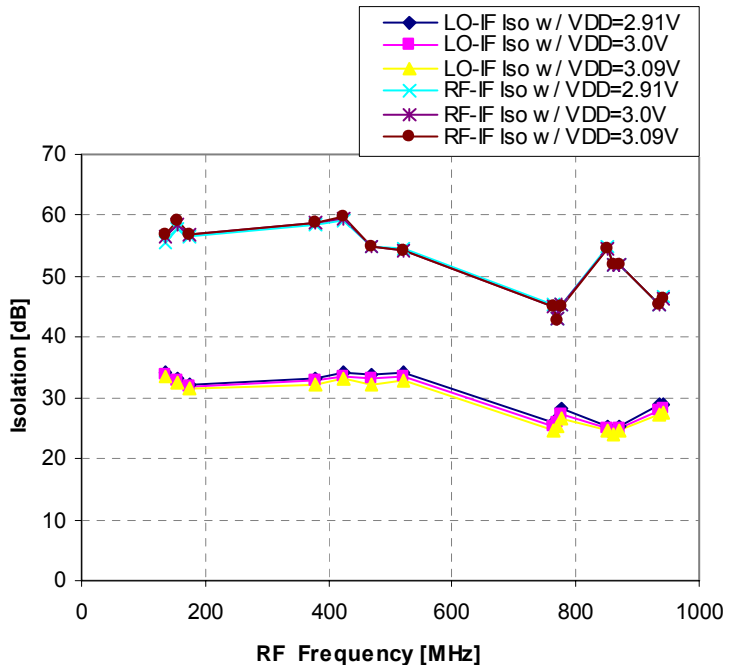

Figure 13. Isolation vs VDD

(Temp = +25 deg C; LO Pwr = -10 dBm)



**Figure 14. Package Drawing**

4x4 mm 20-lead QFN, BOM 19/0106

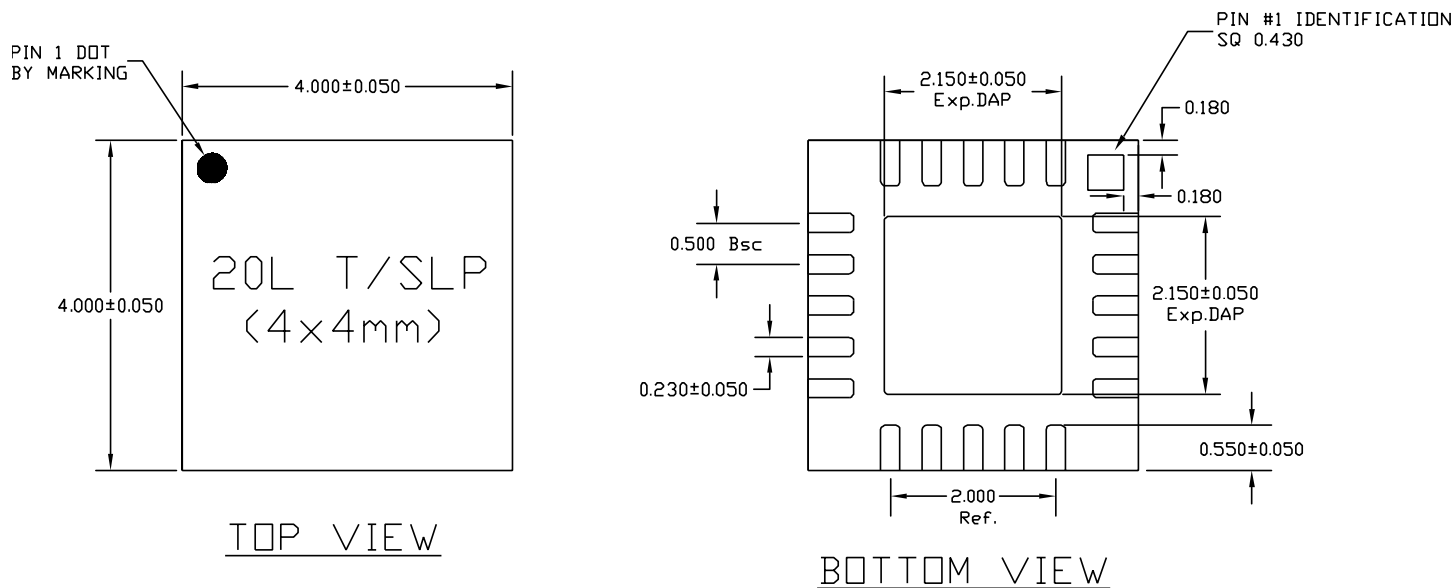

**NOTE:**

1) TSLP AND SLP SHARE THE SAME EXPOSE OUTLINE BUT WITH DIFFERENT THICKNESS:

	TSLP	SLP
A	MAX. 0.800	0.900
	NOM. 0.750	0.850
	MIN. 0.700	0.800

Figure 15. Tape and Reel Drawing

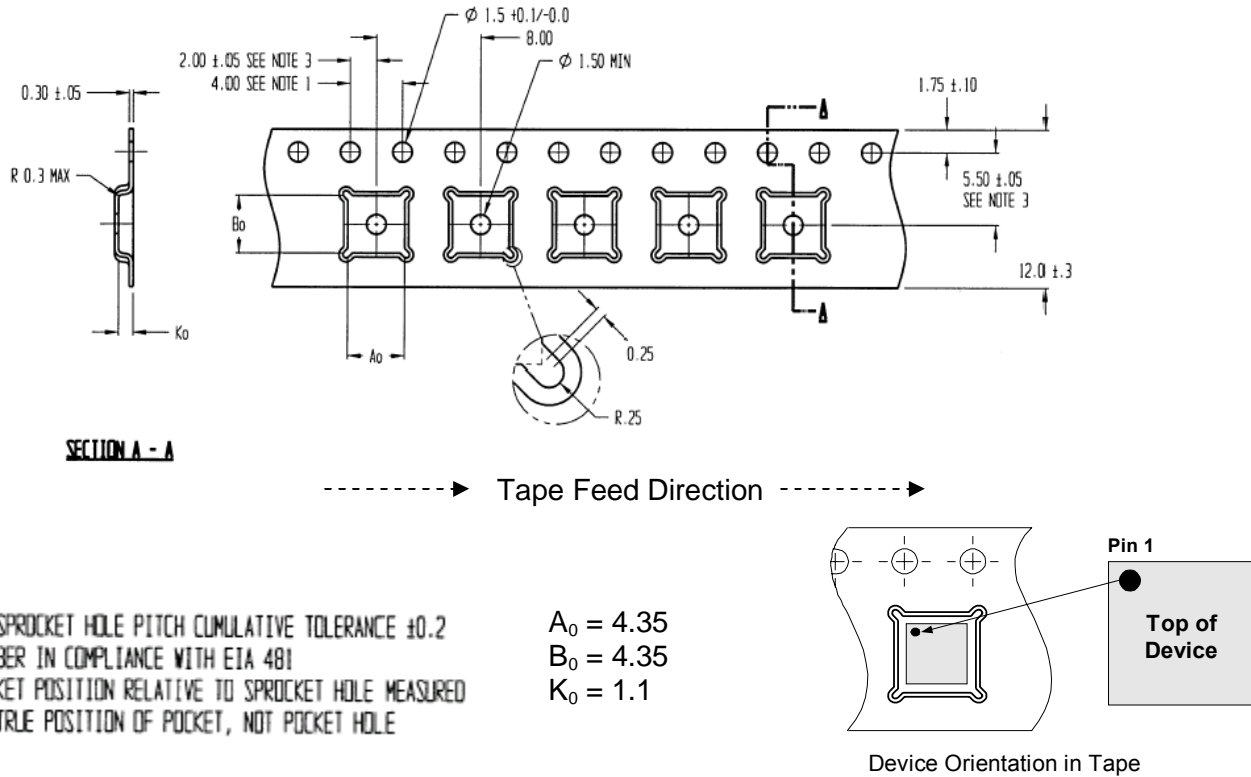
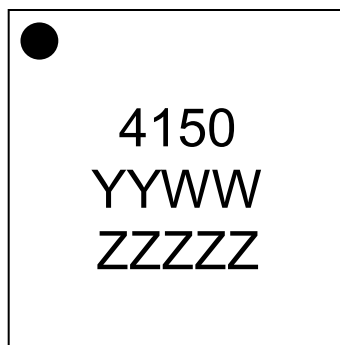

Figure 16. Marking Specification



YYWW = Date Code (Year, Work Week)  
ZZZZZ = Last five digits of PSC Lot Number

Table 5. Ordering Information

Order Code	Part Marking	Description	Package	Shipping Method
EK-4150-01	PE4150 -EK	PE4150 – 20QFN 4x4mm-EK	Evaluation Kit	1 / Box
PE4150 MLI	4150	PE4150 G - 20QFN 4x4mm-75A	Green 20-lead 4x4mm QFN	75 units / Tube
PE4150 MLI-Z	4150	PE4150 G –20QFN 4x4mm-3000C	Green 20-lead 4x4mm QFN	3000 units / T&R

## Sales Offices

### *The Americas*

#### **Peregrine Semiconductor Corporation**

9380 Carroll Park Drive  
San Diego, CA 92121  
Tel: 858-731-9400  
Fax: 858-731-9499

### *Europe*

#### **Peregrine Semiconductor Europe**

Bâtiment Maine  
13-15 rue des Quatre Vents  
F-92380 Garches, France  
Tel: +33-1-4741-9173  
Fax : +33-1-4741-9173

### **High-Reliability and Defense Products**

#### *Americas*

San Diego, CA, USA  
Phone: 858-731-9475  
Fax: 848-731-9499

#### *Europe/Asia-Pacific*

Aix-En-Provence Cedex 3, France  
Phone: +33-4-4239-3361  
Fax: +33-4-4239-7227

For a list of representatives in your area, please refer to our Web site at: [www.psemi.com](http://www.psemi.com)

## Data Sheet Identification

### **Advance Information**

The product is in a formative or design stage. The data sheet contains design target specifications for product development. Specifications and features may change in any manner without notice.

### **Preliminary Specification**

The data sheet contains preliminary data. Additional data may be added at a later date. Peregrine reserves the right to change specifications at any time without notice in order to supply the best possible product.

### **Product Specification**

The data sheet contains final data. In the event Peregrine decides to change the specifications, Peregrine will notify customers of the intended changes by issuing a CNF (Customer Notification Form).

### **Peregrine Semiconductor, Asia Pacific (APAC)**

Shanghai, 200040, P.R. China  
Tel: +86-21-5836-8276  
Fax: +86-21-5836-7652

### **Peregrine Semiconductor, Korea**

#B-2607, Kolon Tripolis, 210  
Geumgok-dong, Bundang-gu, Seongnam-si  
Gyeonggi-do, 463-943 South Korea  
Tel: +82-31-728-3939  
Fax: +82-31-728-3940

### **Peregrine Semiconductor K.K., Japan**

Teikoku Hotel Tower 10B-6  
1-1-1 Uchisaiwai-cho, Chiyoda-ku  
Tokyo 100-0011 Japan  
Tel: +81-3-3502-5211  
Fax: +81-3-3502-5213

The information in this data sheet is believed to be reliable. However, Peregrine assumes no liability for the use of this information. Use shall be entirely at the user's own risk.

No patent rights or licenses to any circuits described in this data sheet are implied or granted to any third party.

Peregrine's products are not designed or intended for use in devices or systems intended for surgical implant, or in other applications intended to support or sustain life, or in any application in which the failure of the Peregrine product could create a situation in which personal injury or death might occur. Peregrine assumes no liability for damages, including consequential or incidental damages, arising out of the use of its products in such applications.

The Peregrine name, logo, and UTSi are registered trademarks and UltraCMOS, HaRP, MultiSwitch and DuNE are trademarks of Peregrine Semiconductor Corp.