

**SANYO Semiconductors****DATA SHEET****LA2360M****Monolithic Linear IC  
CAN Transceiver****Overview**

The LA2360M is a CAN (Controller Area Network) transceiver.

**Functions**

[ Transmitter block ]

- Low-pass filter (EMI prevention)
- Output driver

[ Receiver block ]

- ATT
- Comparator

**Features**

- Conforms to the ISO 11898 standard
- Transmission rate: 1 Mbps

**Specifications****Maximum Ratings** at  $T_a = 25^\circ\text{C}$ 

Parameter	Symbol	Conditions	Ratings	Unit
Maximum supply voltage	$V_{CC\ max}$		6.0	V
Maximum applied voltage	$V_{ap}$		$V_{CC}$	V
Maximum applied voltage (pins 6 and 7)	$V_{ap} (6, 7)$		-8 to +18	V
Allowable power dissipation	$P_d\ max$	*: Mounted on a circuit board, $T_a \leq 85^\circ\text{C}$	440	mW
Operating temperature	$T_{opg}$		-40 to +85	$^\circ\text{C}$
Storage temperature	$T_{stg}$		-55 to +150	$^\circ\text{C}$

\*: Circuit board:  $39.8 \times 50.0 \times 1.6\text{mm}^3$  glass epoxy

**Notice:** Please contact our company, when using the LA2360M in the body system or the power-train system.

- Any and all SANYO Semiconductor products described or contained herein do not have specifications that can handle applications that require extremely high levels of reliability, such as life-support systems, aircraft's control systems, or other applications whose failure can be reasonably expected to result in serious physical and/or material damage. Consult with your SANYO Semiconductor representative nearest you before using any SANYO Semiconductor products described or contained herein in such applications.
- SANYO Semiconductor assumes no responsibility for equipment failures that result from using products at values that exceed, even momentarily, rated values (such as maximum ratings, operating condition ranges, or other parameters) listed in products specifications of any and all SANYO Semiconductor products described or contained herein.

**SANYO Semiconductor Co., Ltd.**

TOKYO OFFICE Tokyo Bldg., 1-10, 1 Chome, Ueno, Taito-ku, TOKYO, 110-8534 JAPAN

Operating Conditions at  $T_a = 25^\circ\text{C}$ 

Parameter	Symbol	Conditions	Ratings	Unit
Recommended supply voltage	$V_{CC}$		5.0	V
Operating supply voltage range	$V_{CC\text{ op}}$		4.5 to 5.5	V

Operating Characteristics at  $T_a = 25^\circ\text{C}$ ,  $V_{CC} = 5.0\text{V}$ 

Parameter	Symbol	Conditions	Ratings			Unit
			min	typ	max	
Overall						
Current drain	$I_{CC}$	Dominant; $V_1 = 1\text{V}$ , $R_8 = 0\Omega$	30		70	mA
		Recessive; $V_1 = 4\text{V}$ , $R_8 = 47\text{k}\Omega$			14	mA
		Recessive; $V_1 = 4\text{V}$ , $R_8 = 0\text{k}\Omega$			18	mA
		Standby; $V_8 = V_{CC}$ , $I_1 = I_4 = I_5 = 0\text{mA}$	30	50	70	$\mu\text{A}$
DC transmitter block						
High-level input voltage	$V_{1IH}$	Output -recessive	$0.7V_{CC}$		$V_{CC}+0.3$	V
Low-level input voltage	$V_{1IL}$	Output -dominant	-0.3		$0.3V_{CC}$	V
High-level input current	$I_{1IH}$	$V_1 = 4\text{V}$	-200		+30	$\mu\text{A}$
Low-level input current	$I_{1IL}$	$V_1 = 1\text{V}$	-600		-100	$\mu\text{A}$
CAN_H output voltage	$V_7$	$V_1 = 1\text{V}$	2.75		4.5	V
CAN_L output voltage	$V_6$	$V_1 = 1\text{V}$	0.5		2.25	V
Recessive state bus voltage	$V_{6,7}$	$V_1 = 4\text{V}$	2.0		3.0	V
Pins 6 and 7 output voltage difference	$\Delta V_{6,7}$	$V_1 = 1\text{V}$	1.5		3.0	V
		$V_1 = 4\text{V}$ ; With no $62\Omega$ resistor	-500		+50	mV
Current when pin 7 grounded	$I_{SC7}$	$V_1 = 1\text{V}$ , $V_7 = -8\text{V}$ ; $V_{CC} = 5\text{V}$			-120	mA
Current when pin 6 shorted to $V_{CC}$	$I_{SC6}$	$V_1 = 1\text{V}$ , $V_6 = 18\text{V}$			160	mA
DC receiver block						
Differential input voltage (recessive)	$V_{\text{diff}}(r)$	Output -recessive	-1.0		0.2	V
		Output -recessive, $0\text{V} < (V_6, V_7) < 12\text{V}$	-1.0		0.1	V
Differential input voltage (dominant)	$V_{\text{diff}}(d)$	Output -dominant	0.9		5.0	V
		Output -dominant, $0\text{V} < (V_6, V_7) < 12\text{V}$	1.0		5.0	V
High-level output voltage (pin 4)	$V_{4OH}$	$I_4 = -100\mu\text{A}$	$0.8V_{CC}$		$V_{CC}$	V
Low-level output voltage (pin 4)	$V_{4OL}$	$I_4 = +100\mu\text{A}$	0		$0.2V_{CC}$	V
Input hysteresis voltage	$V_{\text{diff}}(\text{hys})$		50	80	150	mV
DC standby/slope control block						
High-speed mode input voltage	$V_8$				$0.3V_{CC}$	V
High-speed mode input current	$I_8$	$V_8 = 0\text{V}$			-500	$\mu\text{A}$
Standby mode input voltage	$V_{\text{stb}}$		$0.75V_{CC}$			V
Slope control mode current	$I_{\text{slope}}$	8pin = $47\text{k}\Omega$	-200		-10	$\mu\text{A}$
Slope control mode voltage	$V_{\text{slope}}$	8pin = $47\text{k}\Omega$	$0.4V_{CC}$		$0.6V_{CC}$	V

Continued on next page.

Continued from preceding page.

Parameter	Symbol	Conditions	Ratings			Unit
			min	typ	max	
DC reference block						
Output reference voltage	$V_{ref}$	$V_B = 1V; -50\mu A < I_5 < 50\mu A$	$0.45V_{CC}$		$0.55V_{CC}$	V
		$V_B = 4V; -5\mu A < I_5 < 5\mu A$	$0.4V_{CC}$		$0.6V_{CC}$	V
AC transmitter block						
Pins 6 and 7 differential output pulse width	$t_{width} (diff)$	$V_B = 1V, V_1 = 1MHz$	0.45		0.55	$\mu s$
		$V_B = 1V, V_1 = 100kHz$	4.5		5.5	$\mu s$
Rise delay time	$t_{onTXD}$	$V_B = 1V, V_1 = 1MHz$		40	65	ns
		$V_B = 1V, V_1 = 100kHz$		40	65	ns
Fall delay time	$t_{offTXD}$	$V_B = 1V, V_1 = 1MHz$		40	65	ns
		$V_B = 1V, V_1 = 100kHz$		40	65	ns
AC receiver block (overall) (See note 1.)						
Rise delay time	$t_{onRXD}$	$V_B = 1V, V_1 = 1MHz$		110	160	ns
		$V_B = 1V, V_1 = 100kHz$		110	160	ns
		$R_8 = 47k\Omega, V_1 = 100kHz$		360	500	ns
		$R_8 = 24k\Omega, V_1 = 100kHz$		320	500	ns
Fall delay time	$t_{offRXD}$	$V_B = 1V, V_1 = 1MHz$		90	160	ns
		$V_B = 1V, V_1 = 100kHz$		90	160	ns
		$R_8 = 47k\Omega, V_1 = 100kHz$		600	800	ns
		$R_8 = 24k\Omega, V_1 = 100kHz$		500	800	ns
Pin 8 wakeup time from standby mode	$t_{wake}$	$V_B = 4V \rightarrow 1V, V_8 = 100kHz$			20	$\mu s$
Receiver output response time to a bus level change	$t_{dRXDL}$	$V_1 = 4.0V, V_8 = 4.0V$ [BUS] recessive $\rightarrow$ dominant			3	$\mu s$

Note 1. With an input signal to the transmitter, in automatic send/receive mode

## Package Dimension

unit:mm

3032D

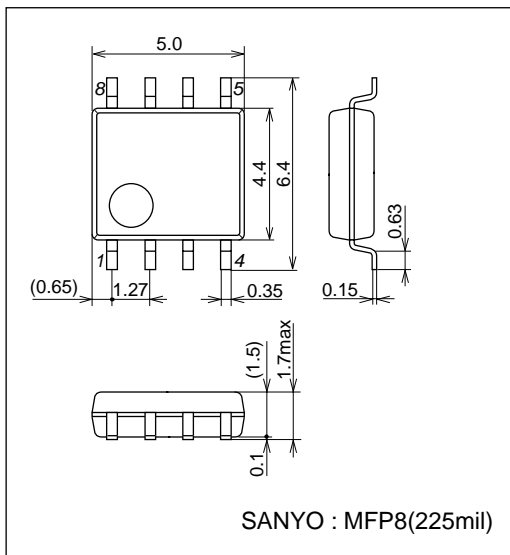

## Block Diagram

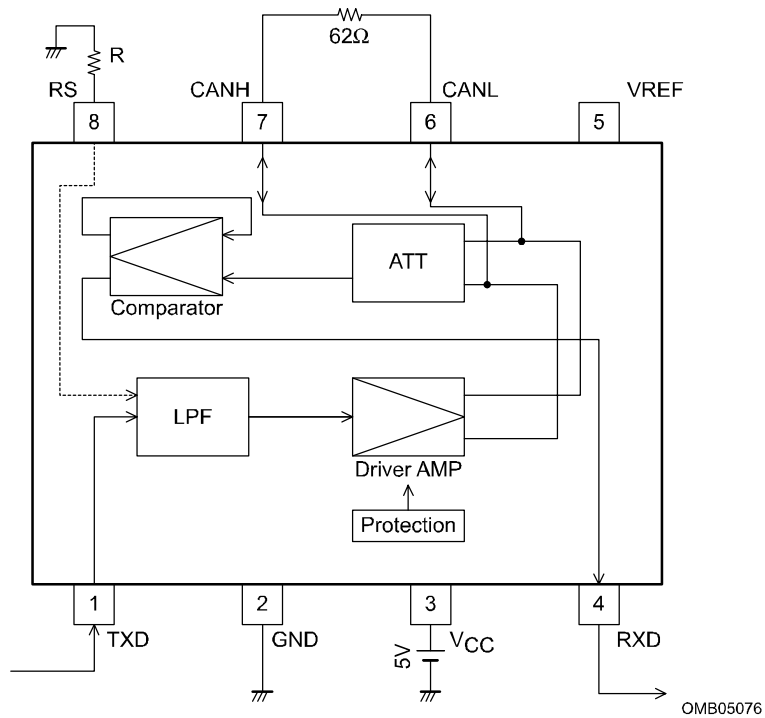

## Pin Functions

Pin No.	Pin	I/O	Function	Description
1	TXD	I	Transmission signal input	Input from the CAN microcontroller
2	GND	P	GND	System ground
3	VCC	P	Power supply	5V
4	RXD	O	Reception signal output	Output to the CAN microcontroller
5	VREF	O	Reference voltage output	2.5V
6	CANL	I/O	Transmission signal output (L)	Input and output of send and receive signals to the bus
7	CANH	I/O	Transmission signal output (H)	Input and output of send and receive signals to the bus
8	RS	I	Mode switching resistor	Slope control Controls standby mode

- Specifications of any and all SANYO Semiconductor products described or contained herein stipulate the performance, characteristics, and functions of the described products in the independent state, and are not guarantees of the performance, characteristics, and functions of the described products as mounted in the customer's products or equipment. To verify symptoms and states that cannot be evaluated in an independent device, the customer should always evaluate and test devices mounted in the customer's products or equipment.
- SANYO Semiconductor Co., Ltd. strives to supply high-quality high-reliability products. However, any and all semiconductor products fail with some probability. It is possible that these probabilistic failures could give rise to accidents or events that could endanger human lives, that could give rise to smoke or fire, or that could cause damage to other property. When designing equipment, adopt safety measures so that these kinds of accidents or events cannot occur. Such measures include but are not limited to protective circuits and error prevention circuits for safe design, redundant design, and structural design.
- In the event that any or all SANYO Semiconductor products (including technical data, services) described or contained herein are controlled under any of applicable local export control laws and regulations, such products must not be exported without obtaining the export license from the authorities concerned in accordance with the above law.
- No part of this publication may be reproduced or transmitted in any form or by any means, electronic or mechanical, including photocopying and recording, or any information storage or retrieval system, or otherwise, without the prior written permission of SANYO Semiconductor Co., Ltd.
- Any and all information described or contained herein are subject to change without notice due to product/technology improvement, etc. When designing equipment, refer to the "Delivery Specification" for the SANYO Semiconductor product that you intend to use.
- Information (including circuit diagrams and circuit parameters) herein is for example only; it is not guaranteed for volume production. SANYO Semiconductor believes information herein is accurate and reliable, but no guarantees are made or implied regarding its use or any infringements of intellectual property rights or other rights of third parties.

This catalog provides information as of January, 2006. Specifications and information herein are subject to change without notice.