

SMC3300-9047	<b>SMC Plug Solder Right Angle</b>	<b>50Ω</b>
--------------	------------------------------------	------------

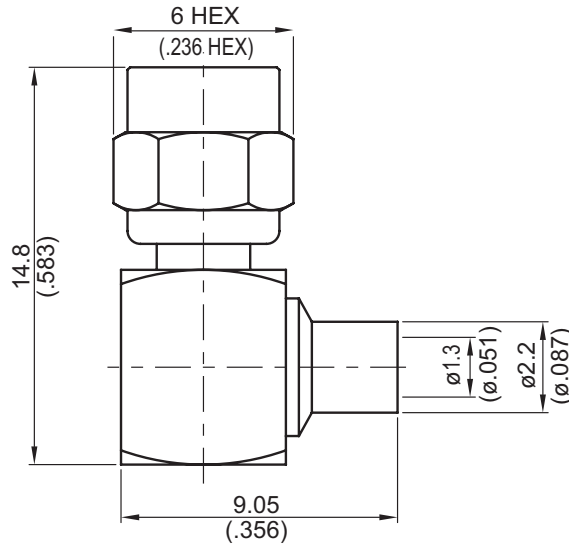

Parts	Material	Plating (Micro-inch)
Cover	Brass	Gold 5 Over Nickel 50 Over Copper 50
Contact Pin	Beryllium Copper	Gold 20 Over Nickel 50 Over Copper 50
Insulator	Teflon	
Body	Brass	Gold 5 Over Nickel 50 Over Copper 50
Barrel	Brass	Gold 5 Over Nickel 50 Over Copper 50
Coupling Nut	Brass	Gold 5 Over Nickel 50 Over Copper 50

Weight:  
Suitable Cables: Semi-rigid.047

**This part number complies with RoHS.**  
**Notice: JYEBAO reserves the right to make modifications deemed appropriate.**

## CABLE ASSEMBLY INSTRUCTION

SMC3300-9047

JYE BAO CO., LTD.

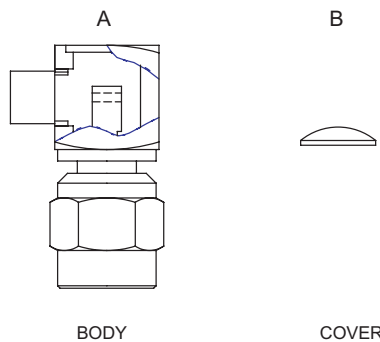

\* TOOLS AND FIXTURES ARE REFERENCE ON  
PAGE 306 OF JYEBAO'S 2005 CATALOG.

DIAGRAM	ASSEMBLY INSTRUCTION
	<p>Step 1: STRIP AS SHOWN .</p>
	<p>Step 2: SLIDE CENTER CONDUCTOR ON THE CONTACT PIN OF CONNECTOR 'A' ,AND SOLDER IN "Y" .</p>
	<p>Step 3: INSERT PREPARED CABLE INTO SOLDERING FIXTURE " ST-008 " . USE INSERT TOOL " ST-047 " AND LOCATOR TOOL " ST-011 " TO FIX THE CONNECTOR . SOLDER IN " Z " .</p>
	<p>Step 4: PRESS ON THE TOP OF 'D' WITH JIGS AS IN THE DIAGRAM .</p>

This part number complies with RoHS.

Notice: JYEBAO reserves the right to make modifications deemed appropriate.