

6367255 MOTOROLA SC (DIODES/OPTO)

34C 38155 D

SILICON THYRISTOR DIE (continued)

T-25-15

CHIP NO. **2C5574**  
LINE SOURCE — DTL0420

Device assembled from this die type are similar to or better than the following device types:



2N5567  
2N5568  
2N5569  
2N5570  
2N5571

2N5572  
2N5573  
2N5574  
MAC15,A Series

TRIAC — Bidirectional  
Triode Thyristor

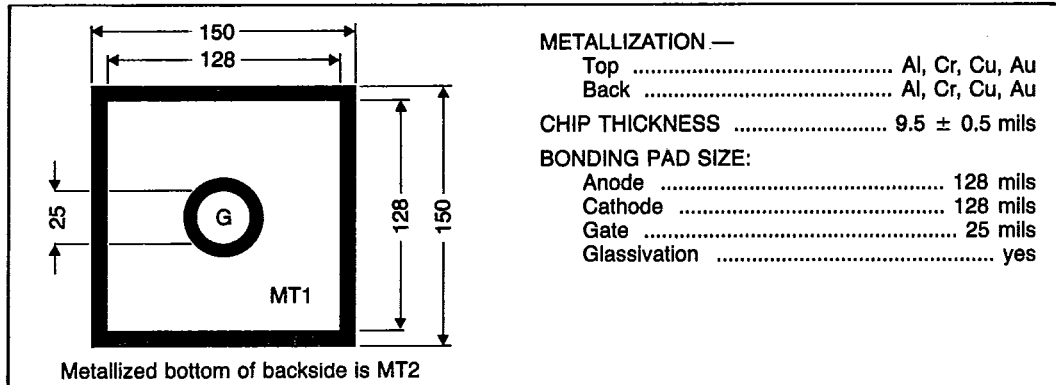

ELECTRICAL CHARACTERISTICS ( $T_A = 25^\circ\text{C}$ , See Note 1)

Parameter	Test Conditions	Min	Max	Unit
$I_{\text{DRM}}$	$V_D = 400 V_{\text{DRM}}$	—	50	$\mu\text{Adc}$
$I_{\text{GT}}$	$V_D = 12 \text{ Vdc}$ , $R_L = 100 \Omega$ MT2(+), G(+)	—	50	mAdc
	MT2(+), G(-)	—	50	
	MT2(-), G(-)	—	50	
	MT2(-), G(+)	—	75	
$V_{\text{GT}}$	$V_D = 12 \text{ Vdc}$ , $R_L = 100 \Omega$ MT2(+), G(+)	—	2.0	Volts
	MT2(+), G(-)	—	2.0	
	MT2(-), G(-)	—	2.0	
	MT2(-), G(+)	—	2.5	
$I_{\text{H}}$	$V_D = 12 \text{ Vdc}$ , $I_{\text{TH}} = 0.2 \text{ Adc}$	—	30	mAdc

NOTES: 1. Because of the limitation of probe testing, dc parameters are tested. These parameters must be measured using pulse techniques pulse width = 300  $\mu\text{A}$  duty cycle  $\leq 2\%$ .

Chip characteristics, including curves, are available from current Discrete Motorola Data.

