

**Low On-Resistance, 3.3V High-Bandwidth  
3-Port, 4:1 Mux/DeMux Video Switch**
**Features**

- Near-Zero propagation delay
- 5Ω switches connect inputs to outputs
- High signal passing bandwidth (375MHz)
- Beyond Rail-to-Rail switching
- 5V I/O tolerant with 3.3V supply
- 2.5V and 3.3V supply voltage operation
- Hot insertion capable (non '-A' part only)
- Low Crosstalk ( $X_{TALK} = -60\text{dB Typ.}$ )
- Low Off-Isolation ( $O_{IRR} = -60\text{db Typ.}$ )
- Industrial operating temperature:  $-40^{\circ}\text{C}$  to  $+85^{\circ}\text{C}$
- ESD Protection:  
PI3V341: I/O pins only have 3kV contact protection  
PI3V341-A: I/O pins only have 8kV contact protection
- Latch-up performance  $>250\text{mA}$  per JESD17
- Packaging (Pb-free & green available):
  - 24-Pin QSOP (Q)
  - 24-Pin TSSOP (L)

**Description**

The PI3V341 is a true bi-directional 3-Port 4:1 multiplexer/demultiplexer with Hi-Z outputs that is recommended for both RGB and composite video switching applications. With the increased 4:1 channels, multiple components, such as VCR, DVD, PC1, PC2 and etc. can be put on the video networks. The VideoSwitch can be driven from a current output RAMDAC or voltage output composite video source.

Low On-Resistance, Low Crosstalk, Low OFF Isolation and wide bandwidth features make it ideal for video and other applications. Industry leading advantages include a near zero propagation delay, resulting from its low channel resistance and I/O capacitance. The switch is bi-directional and offers little or no attenuation of the high-speed signals at the outputs. The device also has exceptional high current capability which is far greater than most analog switches offered today. The PI3V341 offers a high-performance (375 MHz), low-cost solution to switch between video sources.

The PI3V341/-A is an enhanced solution w/ enhanced ESD protection support, up to 8kV contact.

**Applications**

- Projection TV and LCD TV
- Video consumer applications
- Analog video signal processing

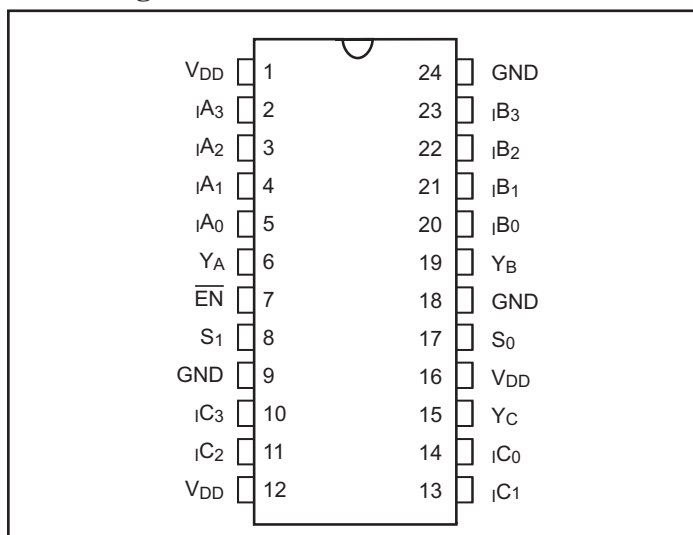
**Pin Configuration**

**Pin Description**

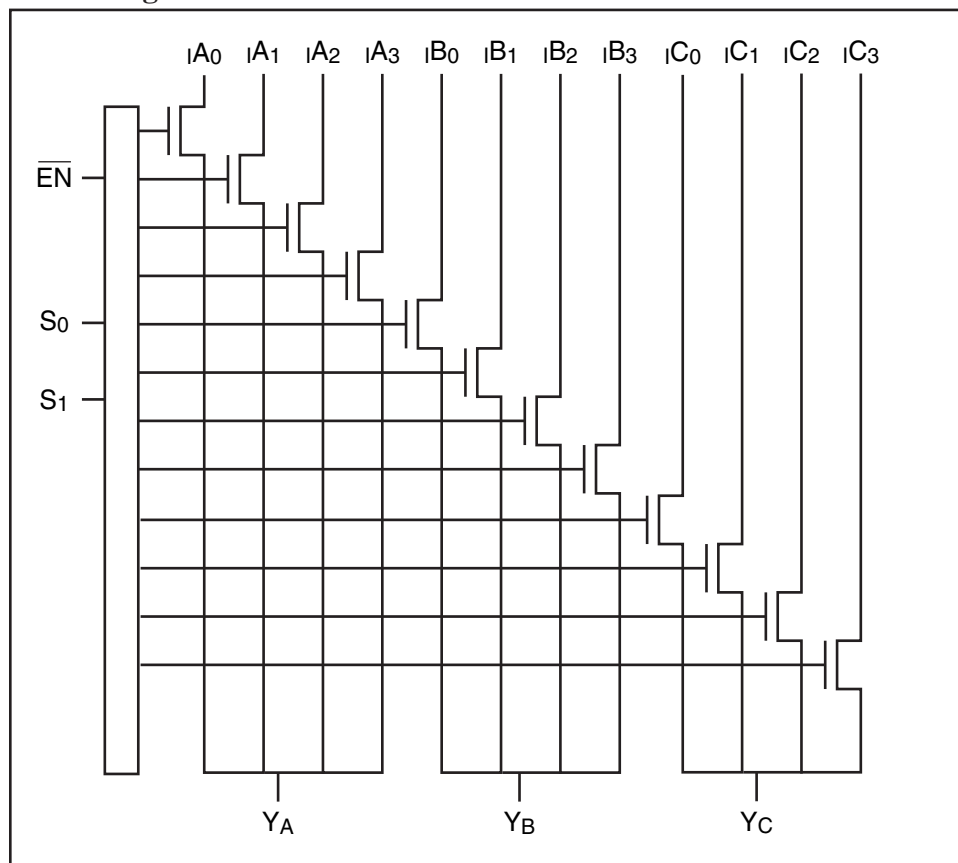
Pin Name	Description
$I_{AN}, I_{BN}$	Data Inputs
$S_0, S_1$	Select Inputs
$\overline{EN}$	Enable
$Y_A$ to $Y_C$	Data Outputs
GND	Ground
$V_{DD}$	Power

**Block Diagram**

**Truth Table 1<sup>(1)</sup>**

Enable	Select		Y <sub>N</sub>	Function
	S <sub>1</sub>	S <sub>0</sub>		
$\overline{\text{EN}}$	X	X	Hi-Z	Disable
H	L	L	I <sub>N0</sub>	S <sub>1</sub> -S <sub>0</sub> = 0
L	L	H	I <sub>N1</sub>	S <sub>1</sub> -S <sub>0</sub> = 1
L	H	L	I <sub>N2</sub>	S <sub>1</sub> -S <sub>0</sub> = 2
L	H	H	I <sub>N3</sub>	S <sub>1</sub> -S <sub>0</sub> = 3

**Notes:**

- N = A, B, C

### Maximum Ratings

(Above which the useful life may be impaired. For user guidelines, not tested.)

Storage Temperature .....	-65°C to +150°C
Ambient Temperature with Power Applied .....	-40°C to +85°C
Supply Voltage to Ground Potential .....	-0.5V to +4.6V
DC Input Voltage .....	-0.5V to +6.0V
DC Output Current.....	120mA
Power Dissipation .....	0.5W

**Note:**

Stresses greater than those listed under MAXIMUM RATINGS may cause permanent damage to the device. This is a stress rating only and functional operation of the device at these or any other conditions above those indicated in the operational sections of this specification is not implied. Exposure to absolute maximum rating conditions for extended periods may affect reliability.

### DC Electrical Characteristics, 3.3V Supply (Over the Operating Range, T<sub>A</sub> = -40°C to +85°C, V<sub>DD</sub> = 3.3V ±10%)

Parameters	Description	Test Conditions <sup>(1)</sup>	Min.	Typ <sup>(2)</sup>	Max.	Units
V <sub>IH</sub>	Input HIGH Voltage	Guaranteed Logic HIGH Level	2.0			V
V <sub>IL</sub>	Input LOW Voltage	Guaranteed Logic LOW Level	-0.5		0.8	
V <sub>IK</sub>	Clamp Diode Voltage	V <sub>DD</sub> = Min., I <sub>IN</sub> = -18 mA		-1.3	-1.8	
I <sub>IH</sub>	Input HIGH Current	V <sub>DD</sub> = Max., V <sub>IN</sub> = V <sub>DD</sub>			±1	µA
I <sub>IL</sub>	Input LOW Current	V <sub>DD</sub> = Max., V <sub>IN</sub> = GND			±1	
I <sub>OZH</sub>	High Impedance Output Current	0 ≤ Y, I <sub>N</sub> = From 0V to 5.5V			±1	
R <sub>ON</sub>	Switch On-Resistance <sup>(4)</sup>	V <sub>DD</sub> = Min., V <sub>IN</sub> = 0V, I <sub>ON</sub> = -48 mA or -64mA		5	7	Ω
		V <sub>DD</sub> = Min., V <sub>IN</sub> = 3.6V, I <sub>ON</sub> = -15 mA		6	8	

### DC Electrical Characteristics, 2.5V Supply (Over Operating Range, T<sub>A</sub> = -40°C to +85°C, V<sub>DD</sub> = 2.5V ± 10%)

Parameters <sup>(5)</sup>	Description	Test Conditions	Min.	Typ.	Max.	Units
V <sub>IH</sub>	Input HIGH Voltage	Guaranteed Logic HIGH Level	1.8		V <sub>DD</sub> + 0.3	V
V <sub>IL</sub>	Input LOW Voltage	Guaranteed Logic LOW Level	-0.3		0.8	
V <sub>IK</sub>	Clamp Diode Voltage	V <sub>DD</sub> = Max., I <sub>IN</sub> = -6mA		-0.7	-1.8	
I <sub>IH</sub>	Input HIGH Current	V <sub>DD</sub> = Max., V <sub>IN</sub> = V <sub>DD</sub>			±1	µA
I <sub>IL</sub>	Input LOW Current	V <sub>DD</sub> = Max., V <sub>IN</sub> = GND			±1	
I <sub>OZH</sub>	High Impedance Current <sup>(3)</sup>	0 ≤ Y, I <sub>N</sub> = From 0V to 5.5V			±1	
R <sub>ON</sub>	Switch On-Resistance <sup>(4)</sup>	V <sub>DD</sub> = Min., V <sub>IN</sub> = 0V, I <sub>ON</sub> = -48mA		6	8	Ω
		V <sub>DD</sub> = Min., V <sub>IN</sub> = 2.25V, I <sub>ON</sub> = -15mA		8	10	

**Capacitance** ( $T_A = 25^\circ\text{C}$   $f = 1\text{ MHz}$ )

Parameters <sup>(5)</sup>	Description	Test Conditions	Typ.	Units
$C_{SX}$	Input Capacitance	$V_{IN} = 0V$	3.0	pF
$C_{OFF(InX)}$	InX Capacitance, Switch Off		3.5	
$C_{OFF(Y)}$	Y Capacitance, Switch Off		12	
$C_{ON}$	Y/In Capacitance, Switch On		15.0	

**Notes:**

1. For Max. or Min. conditions, use appropriate value specified under Electrical Characteristics for the applicable device type.
2. Typical values are at  $V_{DD} = 3.3V$ ,  $T_A = 25^\circ\text{C}$  ambient and maximum loading.
3. Not more than one output should be shorted at one time. Duration of the test should not exceed one second.
4. Measured by the voltage drop between Y and In pin at indicated current through the switch. On-Resistance is determined by the lower of the voltages on the two (Y, In) pins.
5. This parameter is determined by device characterization but is not production tested.

**Power Supply Characteristics**

Parameters	Description	Test Conditions <sup>(1)</sup>	Min.	Typ. <sup>(2)</sup>	Max.	Units
$I_{CC}$	Quiescent Power Supply Current	$V_{DD} = 3.6V$ , $V_S = \text{GND}$ or $V_{DD}$			800	$\mu\text{A}$
		$V_{DD} = 2.75V$ , $V_S = \text{GND}$ or $V_{DD}$			5.5	mA

**Notes:**

1. For Max. or Min. conditions, use appropriate value specified under Electrical Characteristics for the applicable device.
2. Typical values are at  $V_{DD} = 3.3V$ ,  $+25^\circ\text{C}$  ambient.

**Dynamic Electrical Characteristics Over the Operating Range** ( $T_A = -40^\circ$  to  $+85^\circ$ ,  $V_{DD} = 3.3V \pm 10\%$ )

Parameter	Description	Test Condition	Min.	Typ.	Max.	Units
$X_{TALK}$	Crosstalk	See Test Diagram (10 MHz)		-60		dB
$O_{IRR}$	Off-Isolation	See Test Diagram (10 MHz)		-60		
BW	-3dB Bandwidth	See Test Diagram ( $C_L = 0\text{pF}$ )	100	375		MHz

### Switching Characteristics over 3.3V Operating Range

Parameters	Description	Conditions <sup>(1)</sup>	Com.			Units
			Min.	Typ.	Max.	
t <sub>PLH</sub> t <sub>PHL</sub>	Propagation Delay <sup>(2,3)</sup> Y to In, In to Y	See Test Diagram			0.3	ns
t <sub>PZH</sub> t <sub>PZL</sub>	Enable Time S or $\overline{EN}$ to Y or In	See Test Diagram	1.5		9.0	
t <sub>PHZ</sub> t <sub>PLZ</sub>	Disable Time S or $\overline{EN}$ to Y or In		1.5		9.0	

### Switching Characteristics over 2.5V Operating Range

Parameters	Description	Conditions <sup>(1)</sup>	Com.		Units
			Min.	Max.	
t <sub>PLH</sub> t <sub>PHL</sub>	Propagation Delay <sup>(2,3)</sup> Y to In, In to Y	See Test Diagram		0.3	ns
t <sub>PZH</sub> t <sub>PZL</sub>	Enable Time S or $\overline{EN}$ to Y or In	See Test Diagram	1.5	15.0	
t <sub>PHZ</sub> t <sub>PLZ</sub>	Disable Time S or $\overline{EN}$ to Y or In		1.5	12.0	

**Notes:**

1. See test circuit and waveforms.
2. This parameter is guaranteed but not tested on Propagation Delays.
3. The switch contributes no propagational delay other than the RC delay of the On-Resistance of the switch and the load capacitance. The time constant for the switch alone is of the order of 0.30ns for 10pF load. Since this time constant is much smaller than the rise/fall times of typical driving signals, it adds very little propagational delay to the system. Propagational delay of the switch when used in a system is determined by the driving circuit on the driving side of the switch and its interaction with the load on the driven side.

### Bandwidth vs Capacitance

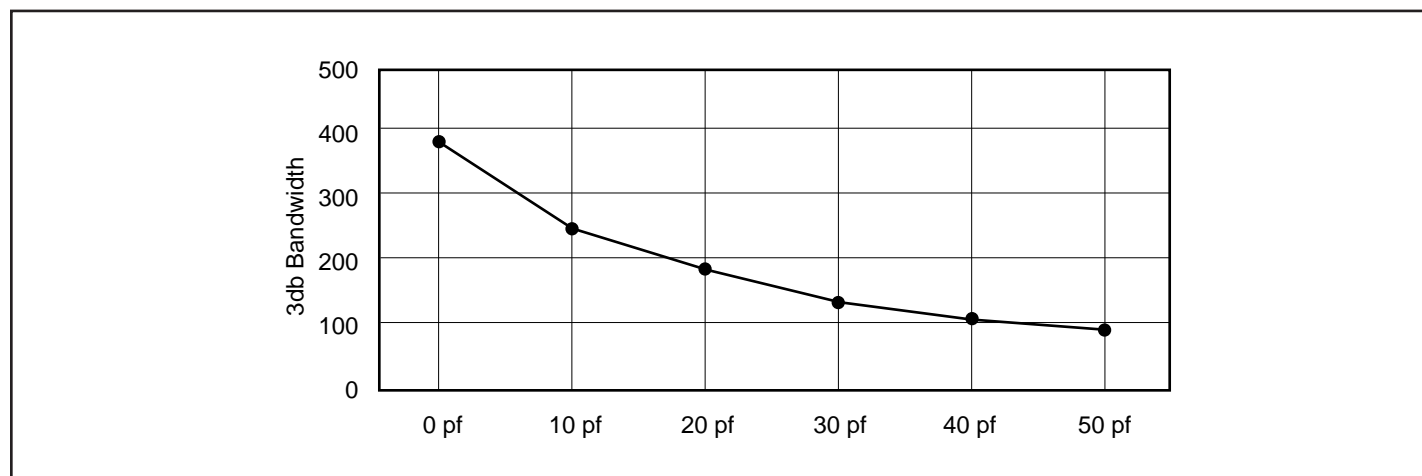

### Test Circuit for Electrical Characteristics<sup>(1)</sup>

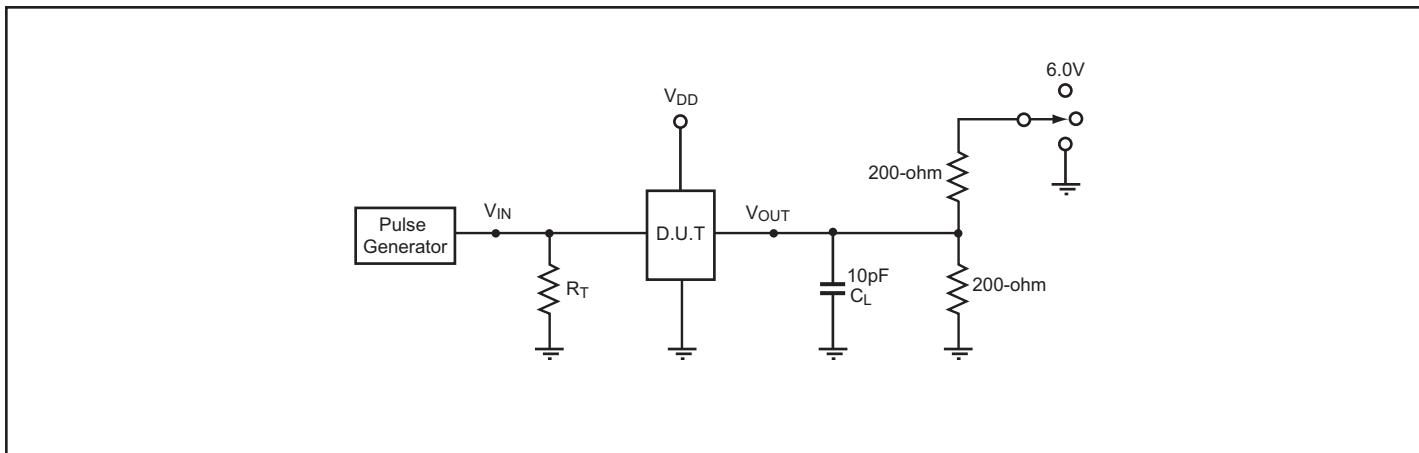

**Notes:**

1.  $C_L$  = Load capacitance: includes jig and probe capacitance.
2.  $R_T$  = Termination resistance: should be equal to  $Z_{OUT}$  of the Pulse Generator
3. Waveform 1 is for an output with internal conditions such that the output is low except when disabled by the output control.  
 Waveform 2 is for an output with internal conditions such that the output is high except when disabled by the output control.
4. All input impulses are supplied by generators having the following characteristics:  $PRR \leq \text{MHz}$ ,  $Z_O = 50\Omega$ ,  $t_R \leq 2.5\text{ns}$ ,  $t_F \leq 2.5\text{ns}$ .
5. The outputs are measured one at a time with one transition per measurement.

### Switch Positions

Test	Switch
$t_{PLZ}$ , $t_{PZL}$	6.0V
$t_{PHZ}$ , $t_{PZH}$	GND
Prop Delay	Open

### Test Circuit for Dynamic Electrical Characteristics

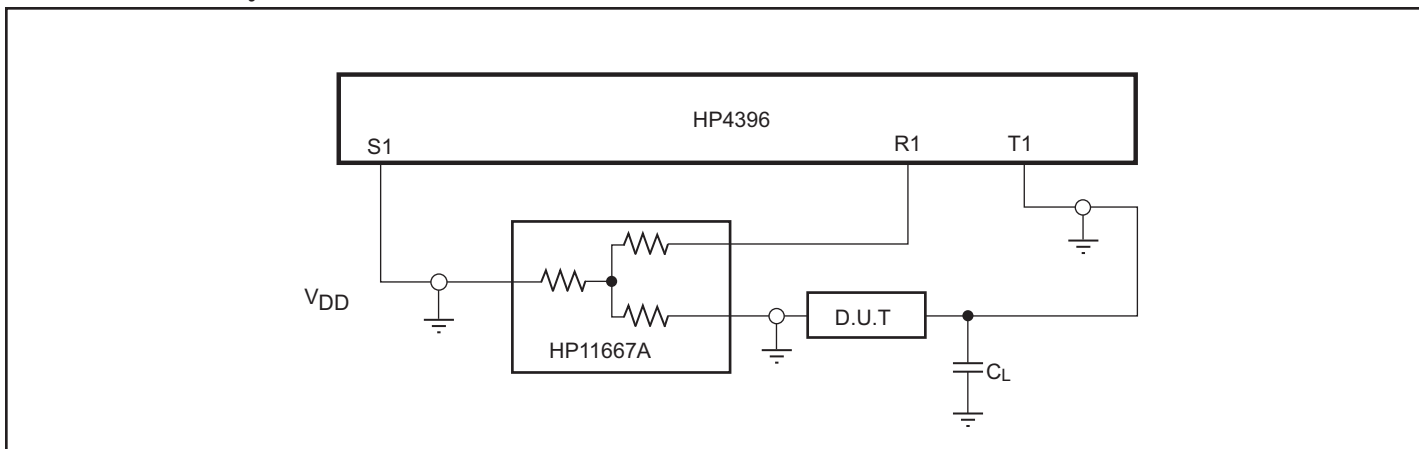

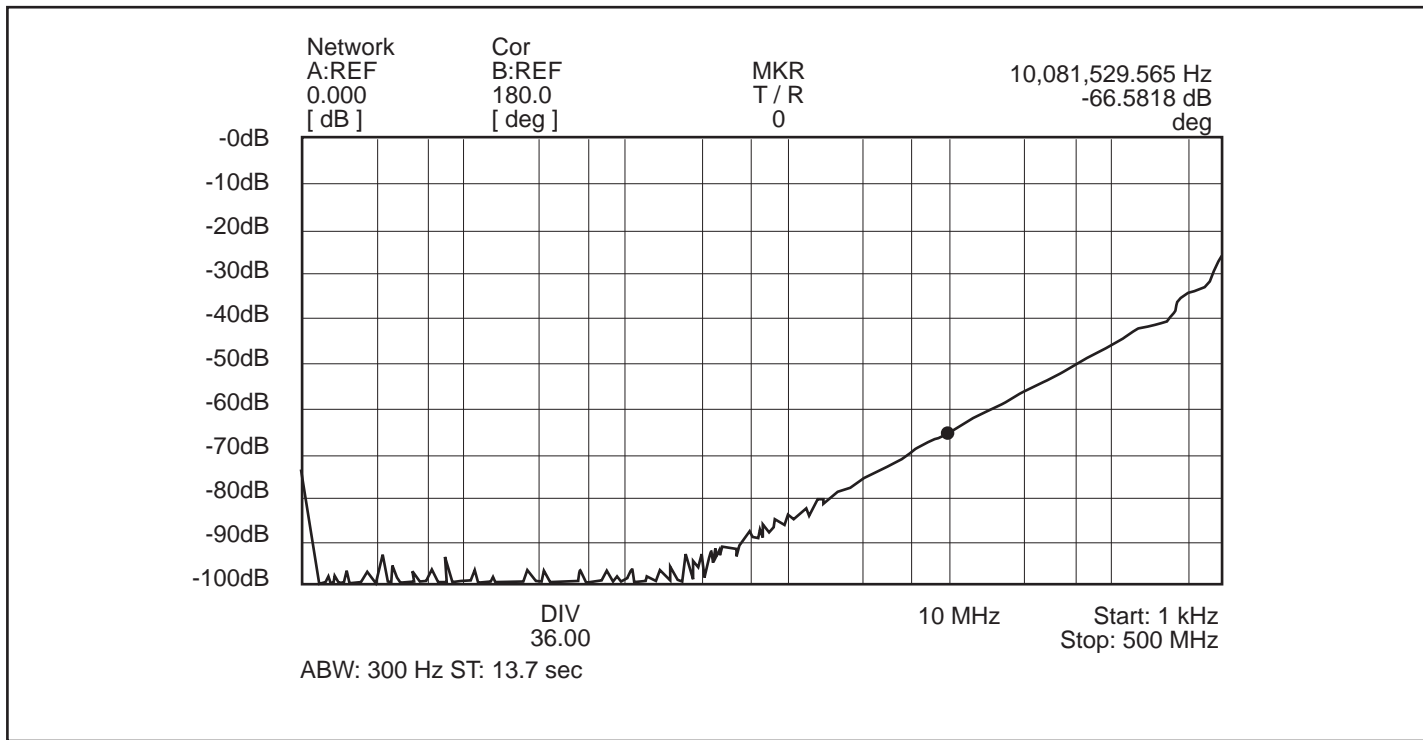
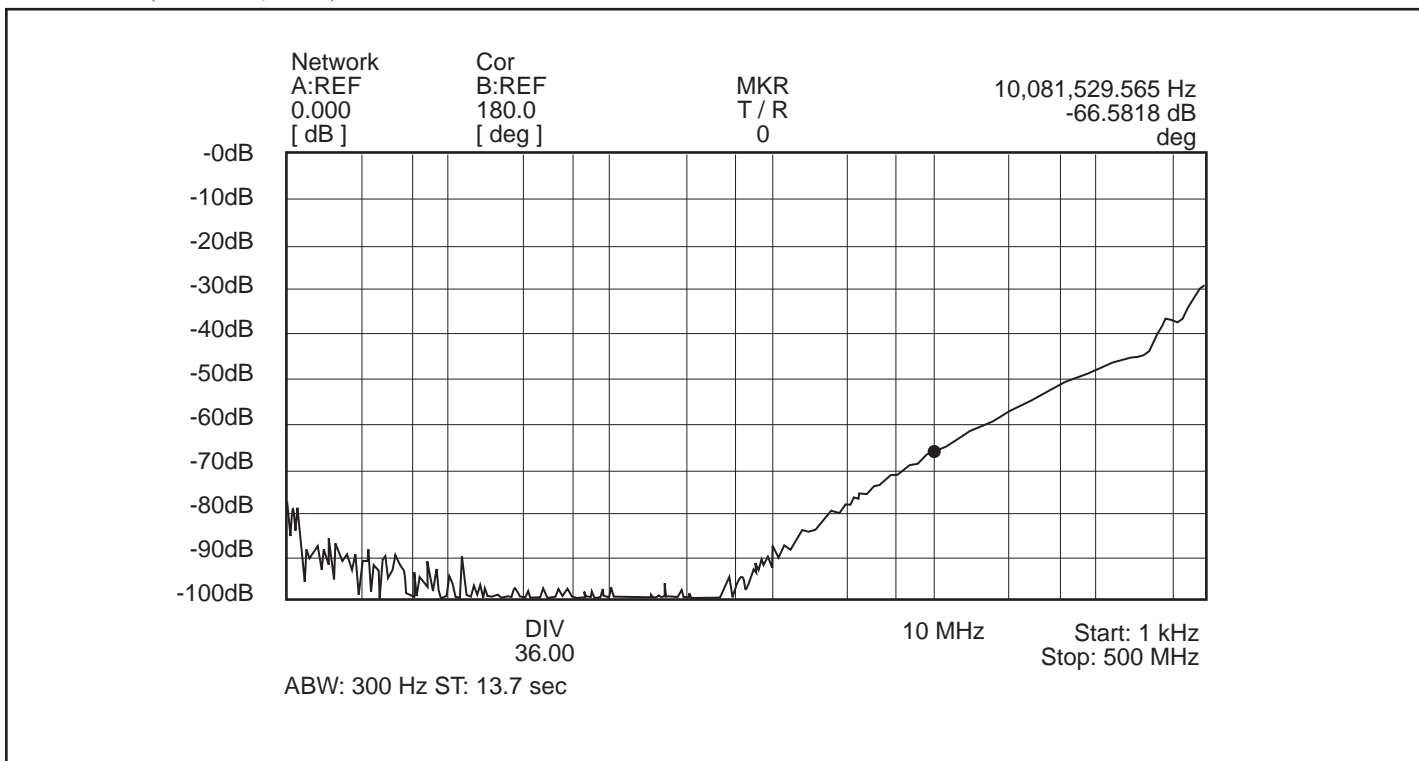
**Off Isolation** ( $V_{DD}$  3.3V, 25°C)

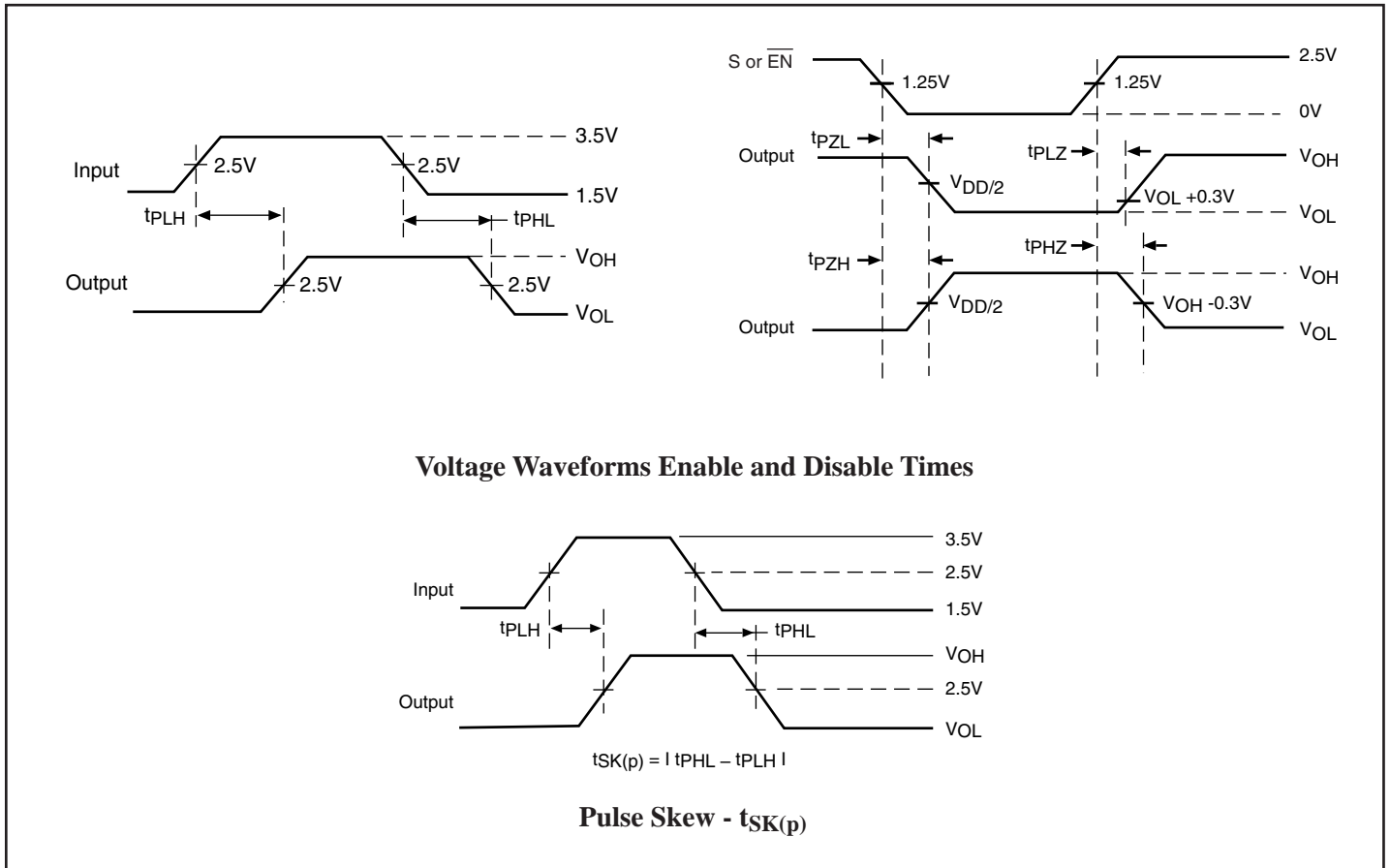
**Crosstalk** ( $V_{DD}$  3.3V, 25°C)

**Switching Waveforms**

## Applications Information

### Logic Inputs

The logic control inputs can be driven upto 3.6V regardless of the supply voltage. For example, given a +3.3V supply,  $\overline{EN}$  maybe driven LOW to 0V and HIGH to 3.6V. Driving  $\overline{EN}$  Rail-to-Rail® minimizes power consumption.

### Hot Insertion

For Datacom and Telecom applications that have ten or more volts passing through the backplane, a high voltage from the power supply may be seen at the device input pins during hot insertion. The PI3Vxxx devices have maximum limits of 6V and 120mA for 20ns. If the power is higher or applied for a longer time or repeatedly reaches the maximum limits, the devices can be damaged.

## Packaging Mechanical: 24-Pin QSOP (Q)

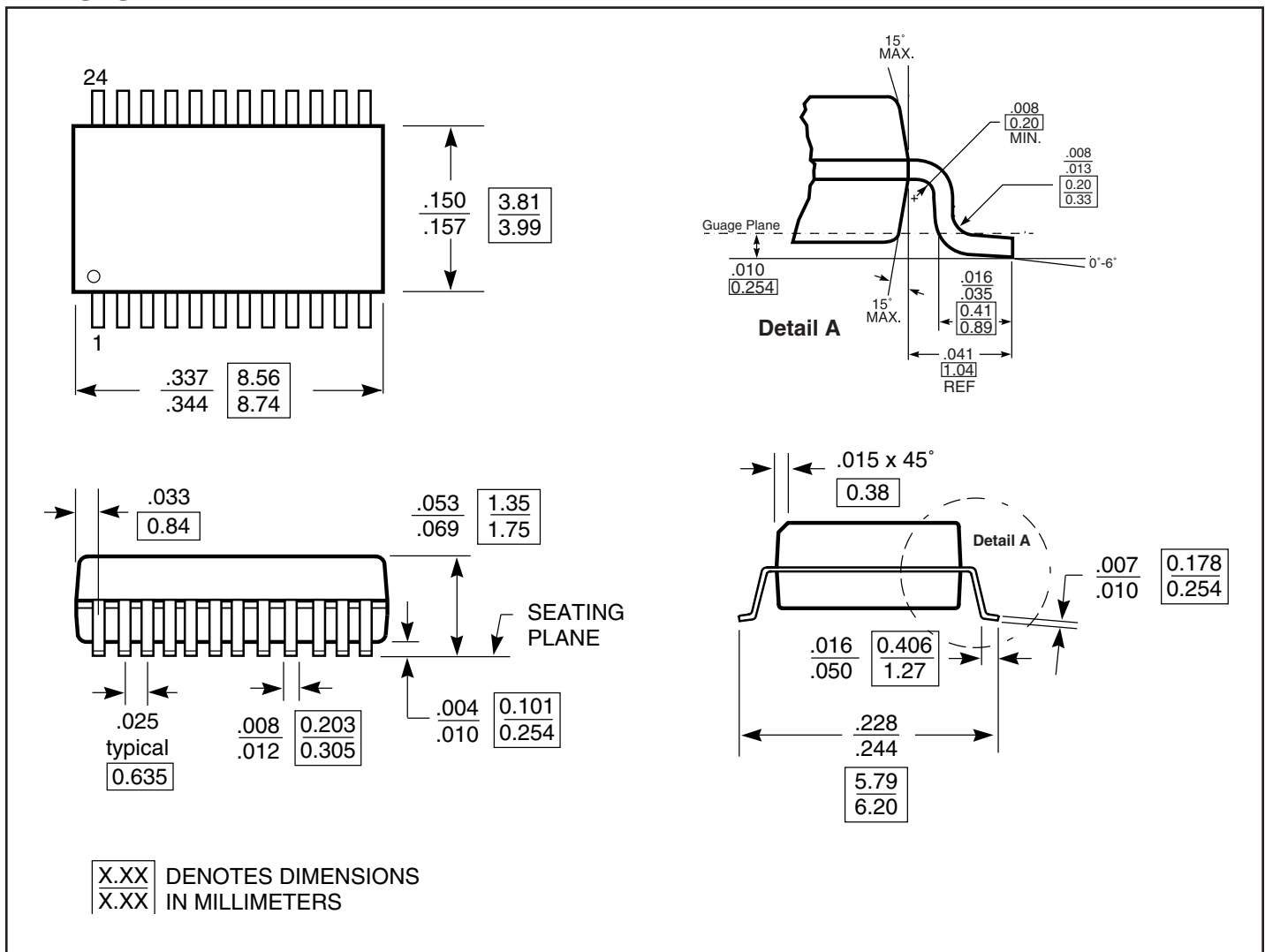

**Packaging Mechanical: 24-Pin TSSOP (L)**

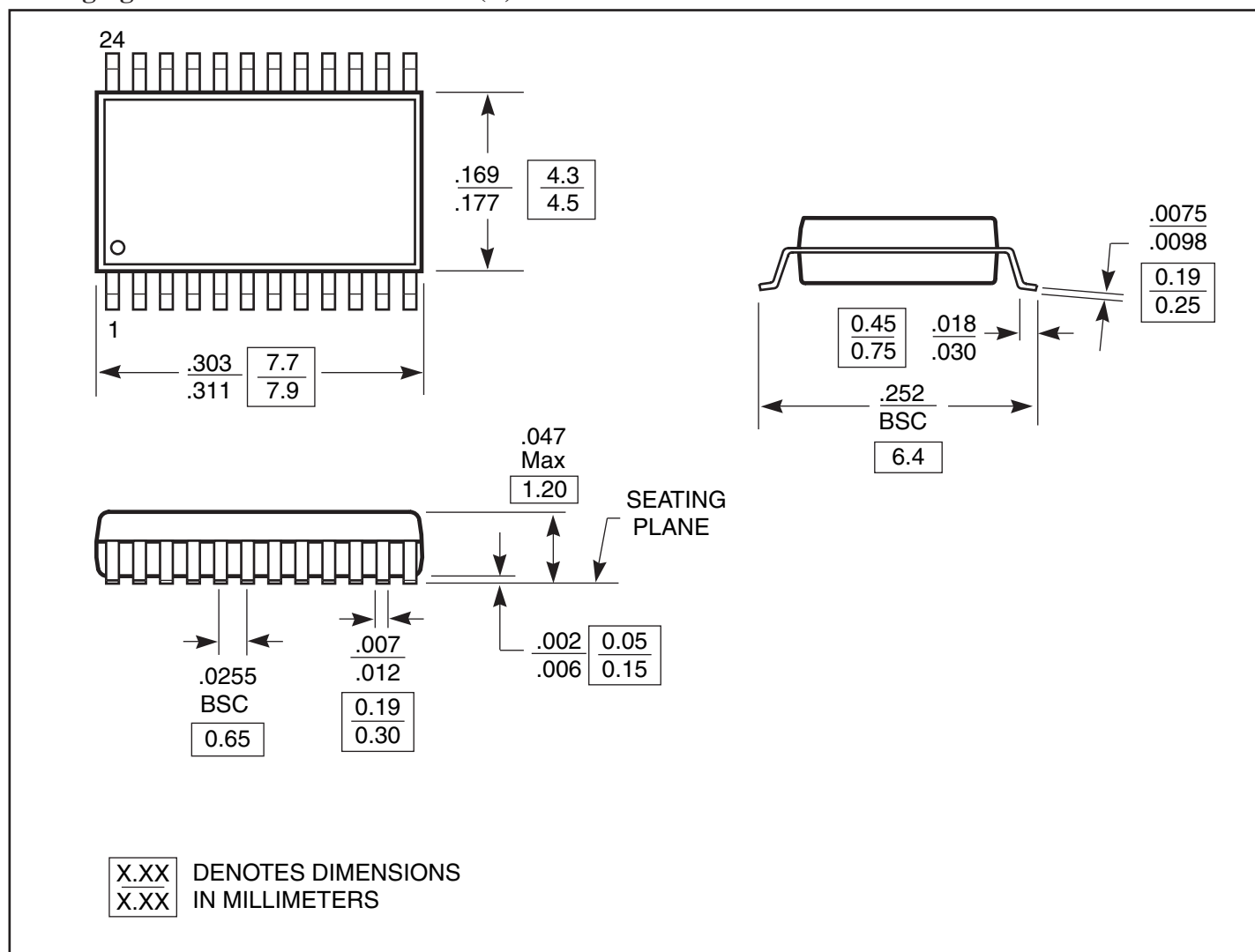

**Ordering Information**

Ordering Code	Packaging Code	Package Description
PI3V341QE	Q	Pb-free & Green, 24-pin QSOP
PI3V341LE	L	Pb-free & Green, 24-pin TSSOP
PI3V341-AQE	Q	Pb-free & Green, 24-pin QSOP
PI3V341-ALE	L	Pb-free & Green, 24-pin TSSOP

**Notes:**

- Thermal characteristics can be found on the company web site at [www.pericom.com/packaging/](http://www.pericom.com/packaging/)
- E = Pb-free and Green
- X suffix = Tape/Reel