

R2S15903SP

Sound Controller with Surround & AGC

REJ03F0159-0140

Rev.1.4

Dec 06, 2005

Description

The R2S15903SP is an optimum audio signal processor IC for TV. It has a 5ch input selector, AGC, surround/pseudo stereo, tone control(2band), output gain control and 2ch master volume. It can control all of these functions with I²C bus.

Features

- Volume: 0 to -89dB, -∞/ 1dB step. Each channel is independence control.
- 5 input selector + MUTE
- 2 Rec output (0/-2dB)
- Auto gain control (AGC level 4step)
- Tone control Bass: -15dB to +15dB/ 1dB step
Treble: -15dB to +15dB/ 1dB step
- Surround <Low/ High>/ Pseudo stereo
- Mode selector: Bypass/ Tone / Tone & Pseudo Stereo or Surround
- Output gain control: 0dB/ +4.5dB
- I²C-BUS control

Recommended Operating Condition

Supply voltage: V_{CC} = 9.0V(typ)

Application

TV, Mini Stereo, etc.

System Configuration

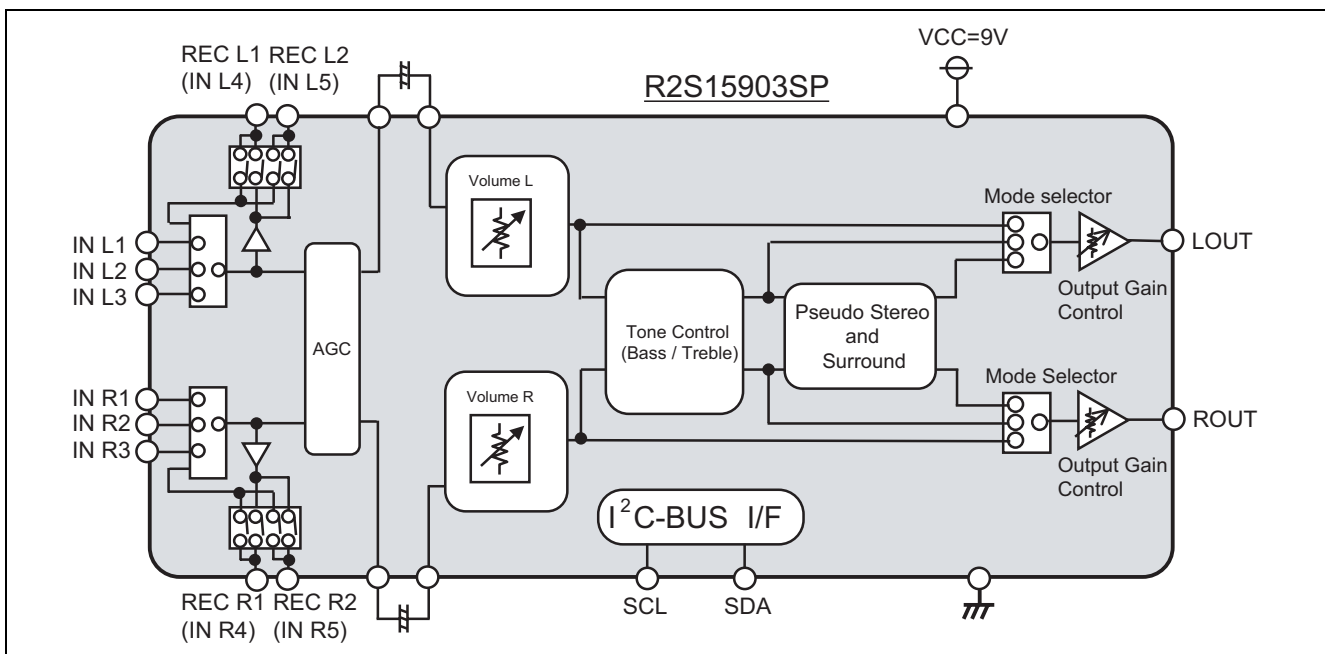

Block Diagram and Pin Configuration

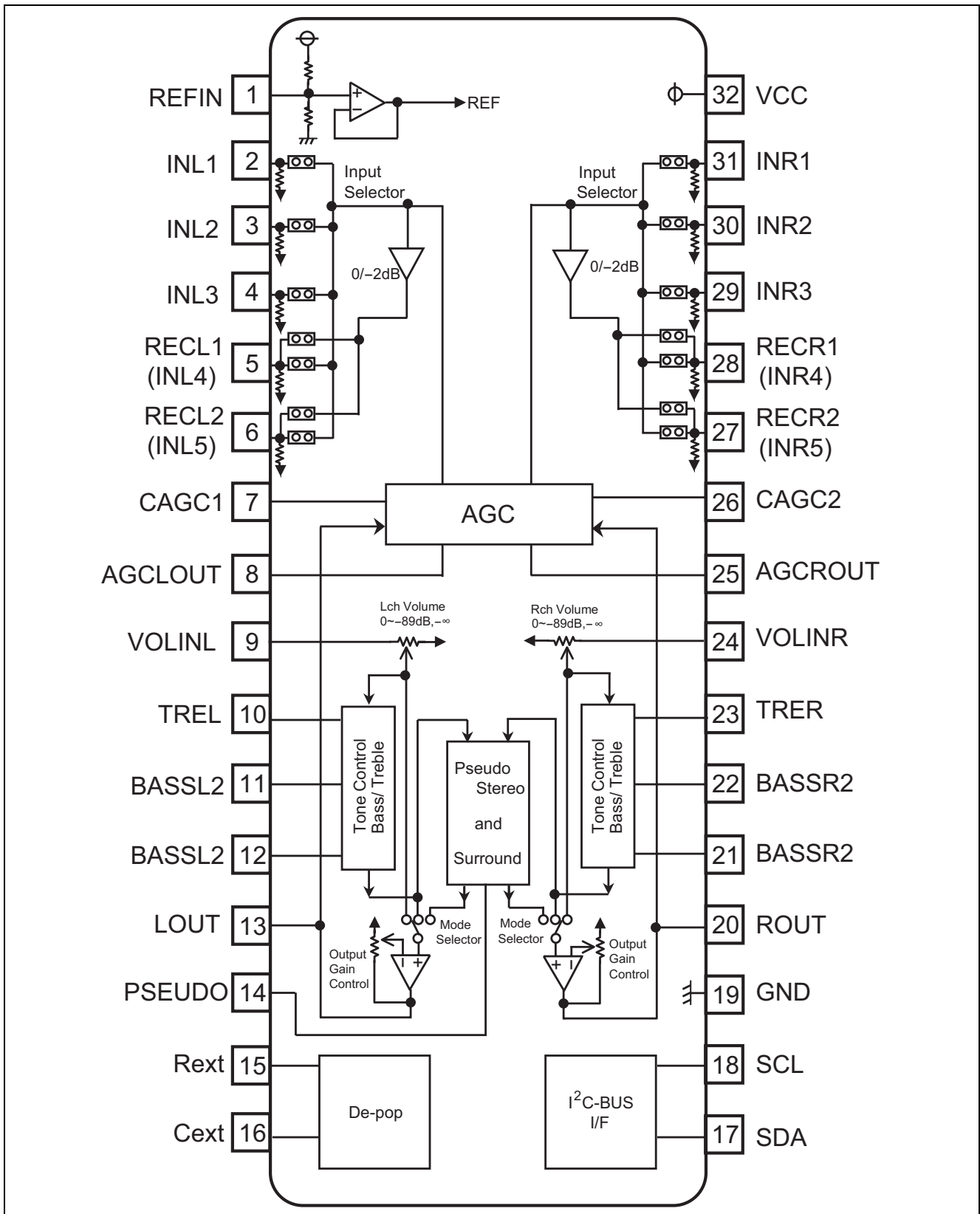

Application Example

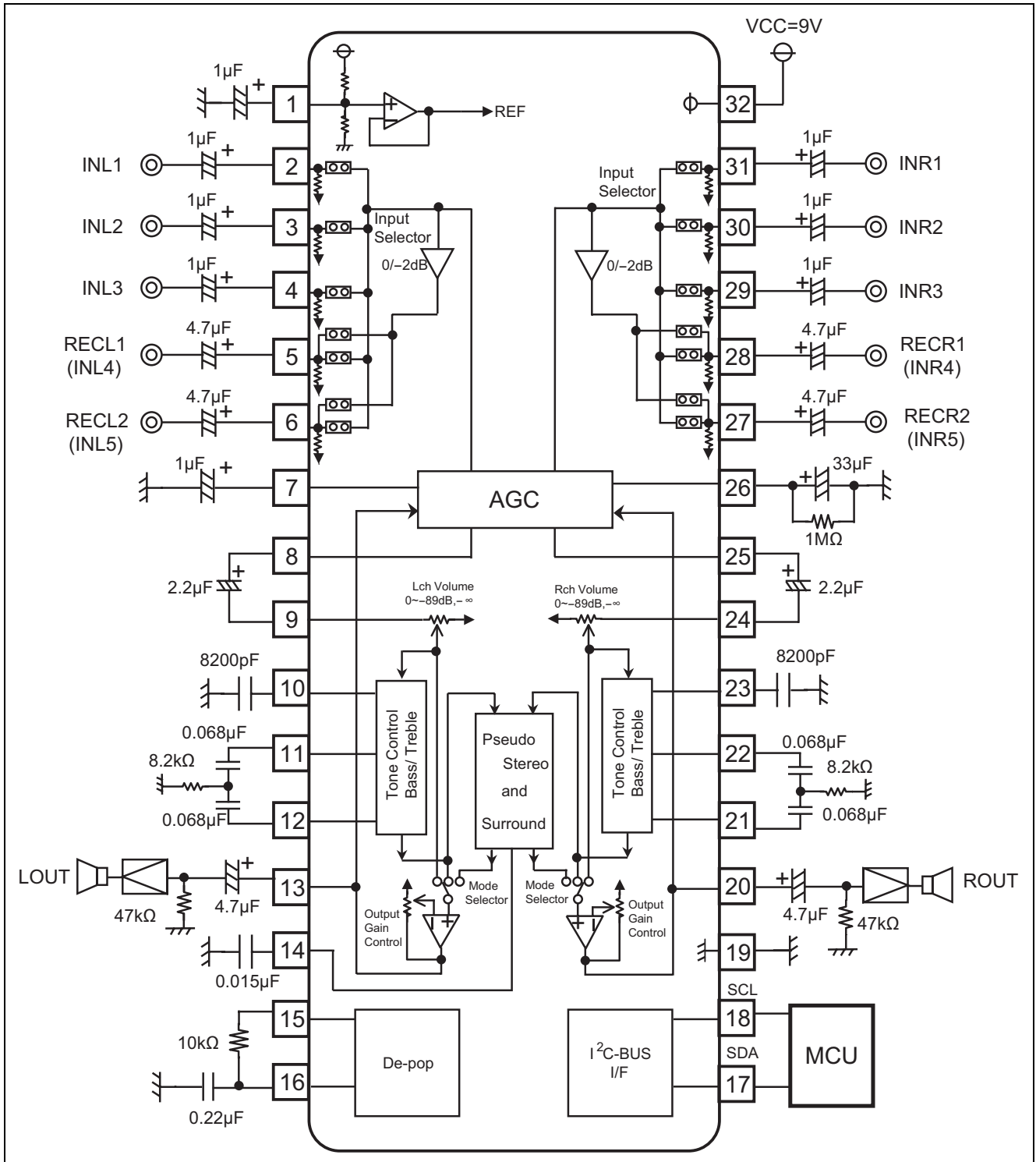

Absolute Maximum Ratings

Parameter	Symbol	Ratings	Unit	Condition
Power supply	V_{CC}	10	V	
Power dissipation	P_d	1.0	W	$T_a \leq 25^\circ\text{C}$
Thermal derating	K	10.0	mW/ $^\circ\text{C}$	$T_a > 25^\circ\text{C}$ (Circuit board installation)
Operating temperature	T_{opr}	-20 to +75	$^\circ\text{C}$	
Storage temperature	T_{stg}	-40 to +125	$^\circ\text{C}$	

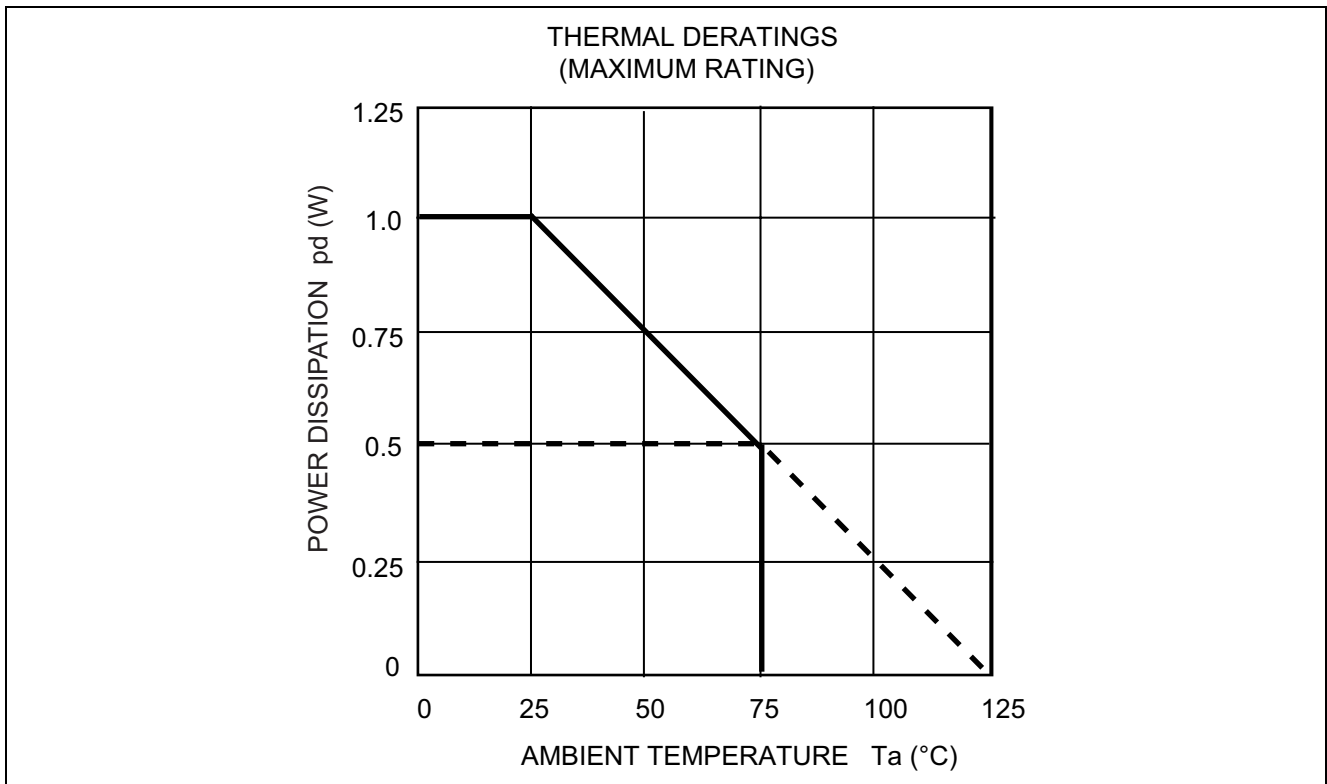

Electrical Characteristics

($V_{CC}=9V$, $T_a=25^{\circ}C$, $V_i=100mV_{rms}$, $f=1kHz$, Bypass, AGC: off, $R_g=0\Omega$, $R_L=47k\Omega$, unless otherwise noted)

General Characteristics

Parameter	Symbol	Limits			Unit	Condition
		Min	Typ	Max		
Operational power supply	V_{CC}	8.0	9.0	9.7	V	
Supply current	I_{CC}	—	25	35	mA	No signal
Reference voltage	V_{ref}	4.0	4.5	5.0	V	No signal
Input impedance	R_{IN}	17	25	33	$k\Omega$	
Maximum input voltage	V_{IM}	2.8	3.0	—	V_{rms}	$VOL=-20dB$, $THD=3\%$
Maximum output voltage	V_{OM}	—	2.5	—	V_{rms}	$VOL=0dB$, $THD=1\%$
Rec output gain	G_{vrec}	—	0/ -2.0	—	dB	Rec out (0/ -2dB)
Output gain	G_{vout}	—	4.5	—	dB	Output gain=4.5dB
Volume maximum	VOL_{max}	-2	0	+2	dB	$VOL=0dB$
Volume minimum	VOL_{min}	—	-85	-70	dB	$VOL=Mute$, $V_{in}=1V_{rms}$, IHF-A
Channel balance	$CBAL$	-1.5	0	1.5	dB	$VOL=0dB$
Total harmonic distortion	THD	—	—	0.5	%	400Hz to 30kHz BPF $V_o=0.5V_{rms}$
Input selector cross talk	CT	—	—	-70	dB	$V_{in}=1V_{rms}$, IHF-A
Channel separation	CS	—	—	-70	dB	$V_{in}=1V_{rms}$, IHF-A,
Output noise 1	V_{no1}	—	-90 (31.6)	-85 (56.2)	dBV (μV_{rms})	$VOL=0dB$, Output gain=0dB Tone=0dB, Surround ON, AGC: OFF, IHF-A
Output noise 2	V_{no2}	—	-103 (7)	-97 (14)	dBV (μV_{rms})	$VOL=Mute$, Output gain=0dB Bypass, AGC: OFF, IHF-A

Tone Control

Parameter	Symbol	Limits			Unit	Condition
		Min	Typ	Max		
Tone control voltage gain (Boost/Bass)	G (Bass) B	+12.5	+15	+17.5	dB	$f = 100Hz$ Bass= + 15dB
Tone control voltage gain (Cut/Bass)	G (Bass) C	-17.5	-15	-12.5	dB	$f = 100Hz$ Bass = -15dB
Tone control voltage gain (Flat/Bass)	G (Bass) F	-2	0	+2	dB	$f = 100Hz$ Bass = 0dB
Tone control voltage gain (Boost/Treble)	G (Treble) B	+12.5	+15	+17.5	dB	$f = 10kHz$ Tre = +15dB
Tone control voltage gain (Cut/Treble)	G (Treble) C	-17.5	-15	-12.5	dB	$f = 10kHz$ Tre = -15dB
Tone control voltage gain (Flat/Treble)	G (Treble) F	-2	0	+2	dB	$f = 100Hz$ Tre = 0dB

AGC

Parameter	Symbol	Limits			Unit	Condition
		Min	Typ	Max		
AGC Boost	AGCBST	1.5	3.5	5.5	dB	AGC level = 300mVrms Vin = 50mVrms, f = 1kHz
AGC FLAT1	AGCFLT1	-2.5	0.0	2.5	dB	AGC level = 300mVrms Vin = 300mVrms, f = 1kHz
AGC FLAT2	AGCFLT2	-2.5	0.0	2.5	dB	AGC level = 400mVrms Vin = 400mVrms, f = 1kHz
AGC FLAT3	AGCFLT3	-2.5	0.0	2.5	dB	AGC level = 500mVrms Vin = 500mVrms, f = 1kHz
AGC FLAT4	AGCFLT4	-2.5	0.0	2.5	dB	AGC level = 600mVrms Vin = 600mVrms, f = 1kHz
AGC CUT	AGCCUT	-14	-10	-6.0	dB	AGC level = 300mVrms Vin = 2Vrms, f = 1kHz

I²C BUS Interface

Parameter	Symbol	Limits			Unit	Condition
		Min	Typ	Max		
Low level input voltage	V _{IL}	0	—	1.5	V	V _{CC} =9V
High level input voltage	V _{IH}	3	—	5	V	V _{CC} =9V
Maximum clock frequency	f _{SCL}			100	kHz	

Function Description

1. Tone Control Circuit

<1> Bass Circuit

Boost

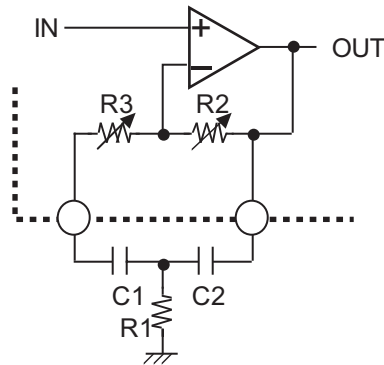

$$f_o = \frac{1}{2\pi\sqrt{R1(R2+R3)C1C2}} \text{ (Hz)}$$

$$Q \cong \frac{1}{C1+C2} \sqrt{\frac{C1C2R2}{R1}} \text{ (R3=0)}$$

$$G_v = 20 \log \left[\frac{\frac{R2+R3}{R1} + 2}{\frac{R3}{R1} + 2} \right] \text{ (dB) (C1=C2)}$$

Cut

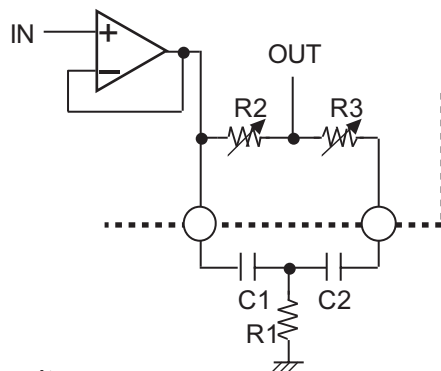

$$f_o = \frac{1}{2\pi\sqrt{R1(R2+R3)C1C2}} \text{ (Hz)}$$

$$Q \cong \frac{1}{C1+C2} \sqrt{\frac{C1C2R2}{R1}} \text{ (R3=0)}$$

$$G_v = 20 \log \left[\frac{\frac{R3}{R1} + 2}{\frac{R2+R3}{R1} + 2} \right] \text{ (dB) (C1=C2)}$$

<2> Treble Circuit

Boost

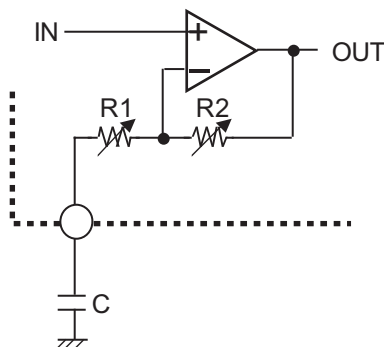

$$G_v = 20 \log \left[\frac{R1+R2}{R1} \right] \text{ (dB)}$$

Cut

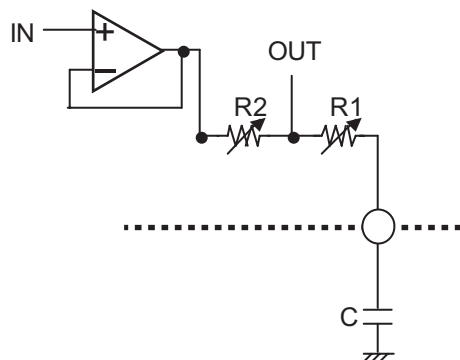

$$G_v = 20 \log \left[\frac{R1}{R1+R2} \right] \text{ (dB)}$$

I²C Bus Format

MSB		LSB		MSB		LSB		MSB		LSB	
S	Slave Address	A	Sub Address	A	Data	A	P				
1 bit	8bit	1 bit	8bit	1 bit	8bit	1 bit	1bit				

S: Starting Term

A: Acknowledge Bit

P: Stop Term

If more than one Data Byte is transmitted, then the significant SUB ADDRESS bits are auto incremented.

00H → 01H → 02H → 03H → 04H → 05H → 00H

1. Slave Address

MSB							LSB
1	0	0	0	0	0	1	R/W _B

R/W_B = 0: Write mode for register setting

R/W_B = 1: Not available

2. Sub Address Table

Sub address	BIT							
	D7	D6	D5	D4	D3	D2	D1	D0
00H	Lch VOL<H>				Lch VOL<L>			
01H	Rch VOL<H>				Rch VOL<L>			
02H	Input selector			Rec output		Output gain	Lch mute	Rch mute
03H	Bass					Surround level	Mode selector	
04H	Treble					Rec gain	0	0
05H	AGC/ Bypass	AGC level		AGC mode	0	0	0	0

3. Data Table

<1> Master Volume Control (Sub Address: 00H, 01H)

VOL ATT (dB)	VOL<H>			
	D7	D6	D5	D4
0	0	0	0	0
-10	0	0	0	1
-20	0	0	1	0
-30	0	0	1	1
-40	0	1	0	0
-50	0	1	0	1
-60	0	1	1	0
-70	0	1	1	1
-80	1	0	0	0

VOL ATT (dB)	VOL<L>			
	D3	D2	D1	D0
0	0	0	0	0
-1	0	0	0	1
-2	0	0	1	0
-3	0	0	1	1
-4	0	1	0	0
-5	0	1	0	1
-6	0	1	1	0
-7	0	1	1	1
-8	1	0	0	0
-9	1	0	0	1

Example: If the volume of the Lch is set to -28dB , the Data byte is transmitted as follows:

Sub address	BIT							
	D7	D6	D5	D4	D3	D2	D1	D0
00H	0	0	1	0	1	0	0	0

<2> Input Selector (Sub Address: 02H)

Input	Input selector			REC1	REC2
	D7	D6	D5	D4	D3
All OFF	0	0	0	A	A
IN1	0	0	1	A	A
IN2	0	1	0	A	A
IN3	0	1	1	A	A
IN4	1	0	0	1	A
IN5	1	0	1	A	1

If A=0 means REC1 or REC2 output ON, then A=1 means REC1 or REC2 output OFF.

<3> Output Gain (Sub Address: 02H)

Gain	Output gain
	D2
0dB	0
+4.5dB	1

<4> Mute Function (Sub Address: 02H)

Mute	Lch	Rch
	D1	D0
Mute ON	0	0
Mute OFF	1	1

<5> Surround Mode (Sub Address: 03H)

Surround level	Surround level
	D2
Low level	0
High level	1

<6> Mode Selector (Sub Address: 03H)

Mode	Mode selector	
	D1	D0
Bypass	0	0
Tone	0	1
Tone & Pseudo stereo	1	0
Tone & Surround	1	1

<7> Tone Control (Sub Address: 03H Bass, 04H Treble)

Gain (dB)	Bass/ Treble				
	D7	D6	D5	D4	D3
0	A	0	0	0	0
1		0	0	0	1
2		0	0	1	0
3		0	0	1	1
4		0	1	0	0
5		0	1	0	1
6		0	1	1	0
7		0	1	1	1
8		1	0	0	0
9		1	0	0	1
10		1	0	1	0
11		1	0	1	1
12		1	1	0	0
13		1	1	0	1
14		1	1	1	0
15		1	1	1	1

If A=0 means Tone control gain CUT(-), then A=1 means Tone control gain BOOST(+).

<8> AGC/ Bypass (Sub Address: 05H)

Mode	Mode selector
	D7
Bypass	0
AGC	1

<9> AGC Level (Sub Address: 05H)

AGC level	AGC level	
	D6	D5
300mVrms	0	0
400mVrms	0	1
500mVrms	1	0
600mVrms	1	1

<10> AGC Mode (Sub Address: 05H)

AGC mode	AGC mode
	D4
Limitation*	0
Always**	1

*: When input level is more than 10mVrms, AGC circuit works.

** : Regardless of input level, AGC circuit always works.

<11> REC Gain (Sub Address: 04H)

Gain	Rec gain
	D2
0dB	0
-2dB	1

Note

1. When power supply is turned on

- Please do not transmit I²C data during 370ms when you turn on the power supply.
(Cext(16pin)=0.22μF , Rext(15-16pin)=10kΩ)

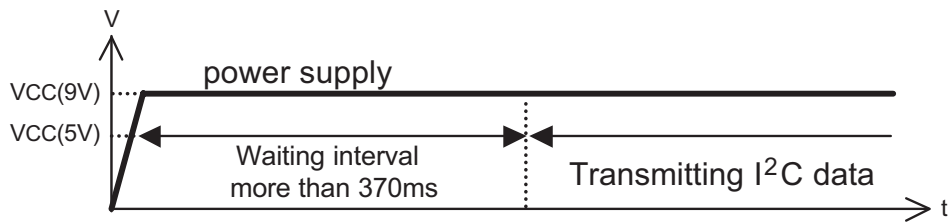

2. When mode is changed

- Please do not transmit I²C data during 370ms when you change the mode selector.
(Cext(16pin)=0.22μF , Rext(15-16pin)=10kΩ)

(EX .1) Bypass → Tone

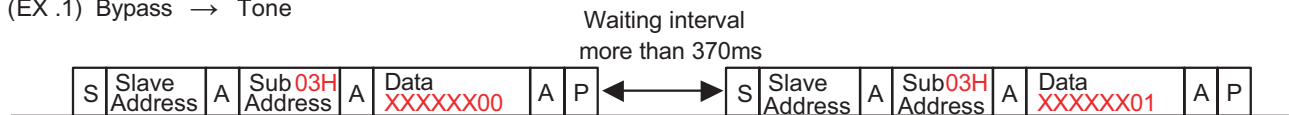

(EX .2) Surround L → Surround H

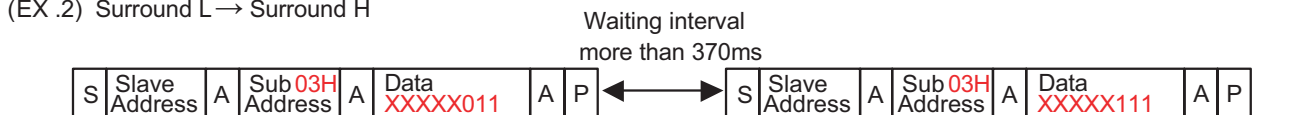

- When the TONE Bass gain is changed, waiting interval is unnecessary.

(EX .3) TONE Bass 1dB → 2dB



Keep safety first in your circuit designs!

1. Renesas Technology Corp. puts the maximum effort into making semiconductor products better and more reliable, but there is always the possibility that trouble may occur with them. Trouble with semiconductors may lead to personal injury, fire or property damage.
Remember to give due consideration to safety when making your circuit designs, with appropriate measures such as (i) placement of substitutive, auxiliary circuits, (ii) use of nonflammable material or (iii) prevention against any malfunction or mishap.

Notes regarding these materials

1. These materials are intended as a reference to assist our customers in the selection of the Renesas Technology Corp. product best suited to the customer's application; they do not convey any license under any intellectual property rights, or any other rights, belonging to Renesas Technology Corp. or a third party.
 2. Renesas Technology Corp. assumes no responsibility for any damage, or infringement of any third-party's rights, originating in the use of any product data, diagrams, charts, programs, algorithms, or circuit application examples contained in these materials.
 3. All information contained in these materials, including product data, diagrams, charts, programs and algorithms represents information on products at the time of publication of these materials, and are subject to change by Renesas Technology Corp. without notice due to product improvements or other reasons. It is therefore recommended that customers contact Renesas Technology Corp. or an authorized Renesas Technology Corp. product distributor for the latest product information before purchasing a product listed herein.
The information described here may contain technical inaccuracies or typographical errors.
Renesas Technology Corp. assumes no responsibility for any damage, liability, or other loss rising from these inaccuracies or errors.
Please also pay attention to information published by Renesas Technology Corp. by various means, including the Renesas Technology Corp. Semiconductor home page (<http://www.renesas.com>).
 4. When using any or all of the information contained in these materials, including product data, diagrams, charts, programs, and algorithms, please be sure to evaluate all information as a total system before making a final decision on the applicability of the information and products. Renesas Technology Corp. assumes no responsibility for any damage, liability or other loss resulting from the information contained herein.
 5. Renesas Technology Corp. semiconductors are not designed or manufactured for use in a device or system that is used under circumstances in which human life is potentially at stake. Please contact Renesas Technology Corp. or an authorized Renesas Technology Corp. product distributor when considering the use of a product contained herein for any specific purposes, such as apparatus or systems for transportation, vehicular, medical, aerospace, nuclear, or undersea repeater use.
 6. The prior written approval of Renesas Technology Corp. is necessary to reprint or reproduce in whole or in part these materials.
 7. If these products or technologies are subject to the Japanese export control restrictions, they must be exported under a license from the Japanese government and cannot be imported into a country other than the approved destination.
Any diversion or reexport contrary to the export control laws and regulations of Japan and/or the country of destination is prohibited.
 8. Please contact Renesas Technology Corp. for further details on these materials or the products contained therein.
-



RENESAS SALES OFFICES

<http://www.renesas.com>

Refer to "<http://www.renesas.com/en/network>" for the latest and detailed information.

Renesas Technology America, Inc.

450 Holger Way, San Jose, CA 95134-1368, U.S.A
Tel: <1> (408) 382-7500, Fax: <1> (408) 382-7501

Renesas Technology Europe Limited

Dukes Meadow, Millboard Road, Bourne End, Buckinghamshire, SL8 5FH, U.K.
Tel: <44> (1628) 585-100, Fax: <44> (1628) 585-900

Renesas Technology (Shanghai) Co., Ltd.

Unit 205, AZIA Center, No.133 Yincheng Rd (n), Pudong District, Shanghai 200120, China
Tel: <86> (21) 5877-1818, Fax: <86> (21) 6887-7898

Renesas Technology Hong Kong Ltd.

7th Floor, North Tower, World Finance Centre, Harbour City, 1 Canton Road, Tsimshatsui, Kowloon, Hong Kong
Tel: <852> 2265-6688, Fax: <852> 2730-6071

Renesas Technology Taiwan Co., Ltd.

10th Floor, No.99, Fushing North Road, Taipei, Taiwan
Tel: <886> (2) 2715-2888, Fax: <886> (2) 2713-2999

Renesas Technology Singapore Pte. Ltd.

1 Harbour Front Avenue, #06-10, Keppel Bay Tower, Singapore 098632
Tel: <65> 6213-0200, Fax: <65> 6278-8001

Renesas Technology Korea Co., Ltd.

Kukje Center Bldg. 18th Fl., 191, 2-ka, Hangang-ro, Yongsan-ku, Seoul 140-702, Korea
Tel: <82> (2) 796-3115, Fax: <82> (2) 796-2145

Renesas Technology Malaysia Sdn. Bhd

Unit 906, Block B, Menara Amcorp, Amcorp Trade Centre, No.18, Jalan Persiaran Barat, 46050 Petaling Jaya, Selangor Darul Ehsan, Malaysia
Tel: <603> 7955-9390, Fax: <603> 7955-9510