

SERIES: VFK400W-DIN | **DESCRIPTION:** DC-DC CONVERTER

FEATURES

- up to 400 W isolated output
- rugged metal enclosure with integrated heat sink
- 4:1 input range (10~36 Vdc, 18~75 Vdc)
- single output from 12~48 Vdc
- 1,500 Vdc isolation
- over current, over temperature, over voltage, and short circuit protection
- remote on/off
- efficiency up to 87%
- comes with DIN-rail mount



MODEL	input voltage range (Vdc)	output voltage (Vdc)	output current max (A)	output power max (W)	ripple and noise¹ max (mVp-p)	efficiency max (%)
VFK400W-Q24-S12-DIN	10~36	12	33.3	400	200	87
VFK400W-Q24-S24-DIN	10~36	24	16.7	400	240	86
VFK400W-Q24-S48-DIN	10~36	48	8.3	398	480	86
VFK400W-Q48-S12-DIN ²	20~75	12	33.3	400	200	87
VFK400W-Q48-S24-DIN	18~75	24	16.7	400	240	86
VFK400W-Q48-S48-DIN	18~75	48	8.3	398	480	86.5

Note: 1. Ripple and noise are measured at full load, 20 MHz BW with 10µF tantalum capacitor and 1µF ceramic capacitor across the output. The 48 Vdc output models require a 22µF aluminum capacitor and a 1µF ceramic capacitor across the output.
 2. An external input capacitor of 470µF is recommended to reduce input ripple voltage.

PART NUMBER KEY

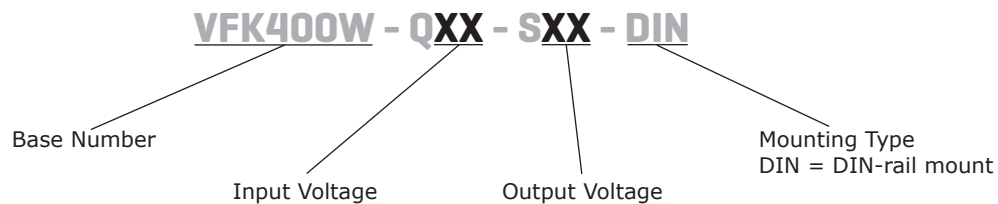

INPUT

parameter	conditions/description	min	typ	max	units
operating input voltage	24 Vdc input	10	24	36	Vdc
	48 Vdc input	12 Vdc output model 24/48 Vdc output models	20 18	48 48	75 75
under voltage shutdown	24 Vdc input	power up power down		9.5 8.5	Vdc Vdc
	48 Vdc input	power up power down		17.8 15.5	Vdc Vdc
CTRL ¹	positive logic	models ON (>3.5 Vdc or open circuit)			
		models OFF (0~1.2 Vdc)			
filter	pi filter				

Note: 1. Open collector refer to -Vin

OUTPUT

parameter	conditions/description	min	typ	max	units
maximum output capacitance	for all models			2,200	μF
line regulation	measured from high line to low line			±1	%
load regulation	measured from full load to zero load			±1	%
voltage accuracy				±1.5	%
adjustability		90		105	%
switching frequency			250		kHz
transient response	25% step load change			500	μs
temperature coefficient			±0.03		%/°C

PROTECTIONS

parameter	conditions/description	min	typ	max	units
short circuit protection	continuous				
over current protection	% nominal output current	110		150	%
over voltage protection		115		140	%
over temperature protection	shutdown		110		°C

SAFETY AND COMPLIANCE

parameter	conditions/description	min	typ	max	units
isolation voltage	for 1 minute: input to output; input to case; output to case	1,500			Vdc
isolation resistance		10			MΩ
RoHS	2011/65/EU (CE)				

ENVIRONMENTAL

parameter	conditions/description	min	typ	max	units
operating temperature	see derating curves	-40		85	°C
storage temperature		-55		105	°C

MECHANICAL

parameter	conditions/description	min	typ	max	units
dimensions	7.83 x 5.00 x 2.11 (199.0 x 127.0 x 53.6 mm)				inch
case material	steel and aluminum extrusion				
weight			1.53		kg

MECHANICAL DRAWING

units: inch[mm]

tolerance: X.XX = $\pm 0.02[\pm 0.5]$
 X.XXX = $\pm 0.010[\pm 0.25]$

wire range: 22~12 AWG

screw size: #6-32

mounts to TS35 rails

PIN CONNECTIONS	
PIN	FUNCTION
1, 2	+Vin
3, 4	-Vin
5	REM
6	CASE
7, 8	+Vout
9	+S
10	TRIM
11	-S
12, 13	-Vout

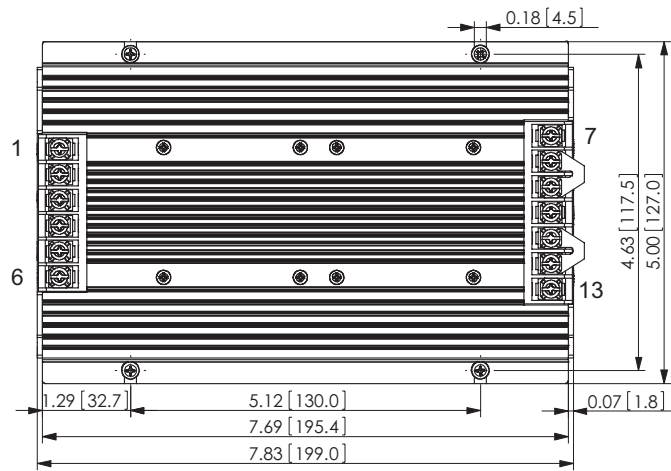

Top View

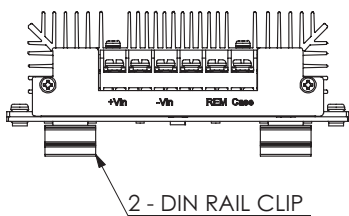

Front View

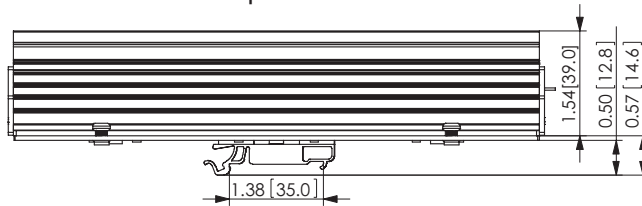

Side View

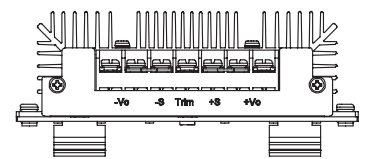

Back View

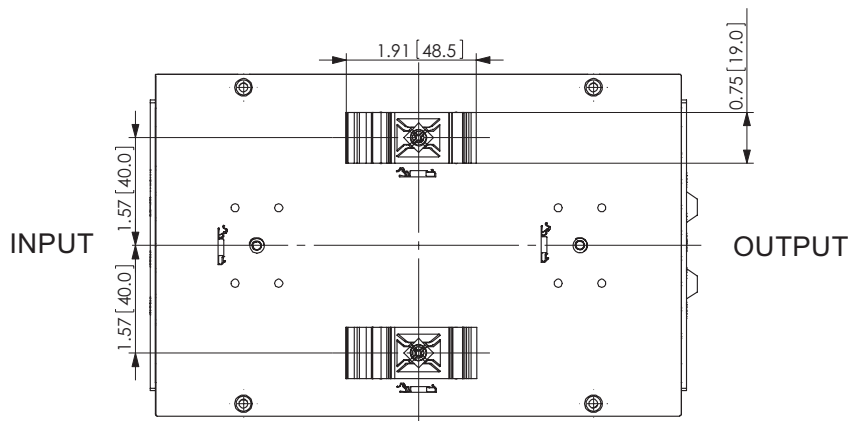

Bottom View

DERATING CURVES

VFK400W-DIN Power Derating Curves At Nominal Input
(Includes VFK400W-Q24-S12-DIN and all 48 Vdc input models)

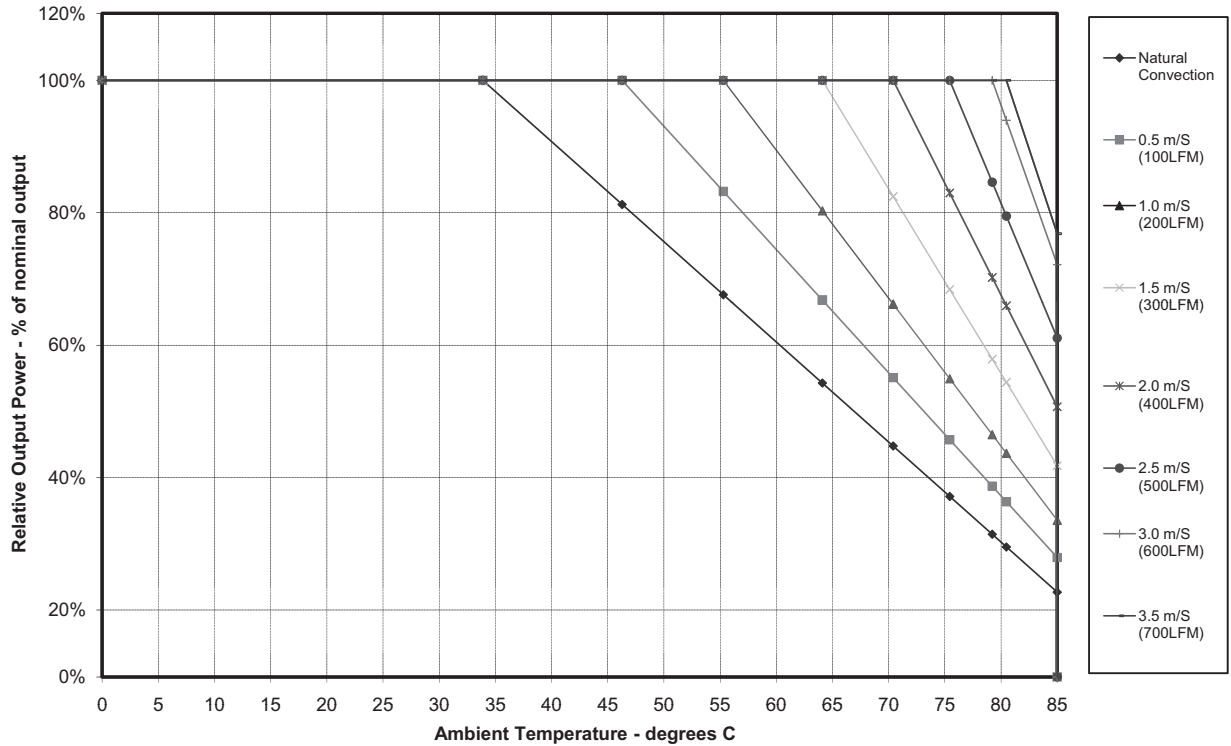

VFK400W-DIN Power Derating Curves At Nominal Input
(Includes VFK400W-Q24-S24-DIN and VFK400W-Q24-S48-DIN)

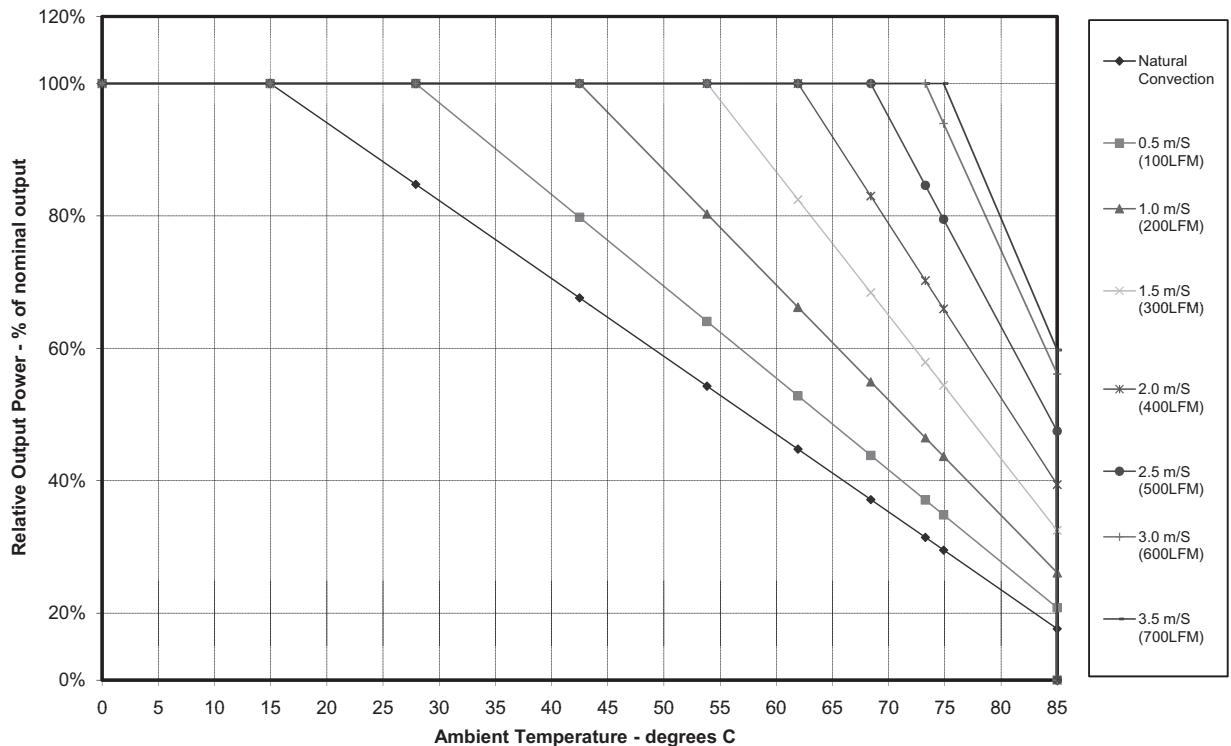

APPLICATION NOTES

1. Output Voltage Trimming

Leave open if not used.

Figure 1
Application Circuit for Trim pin

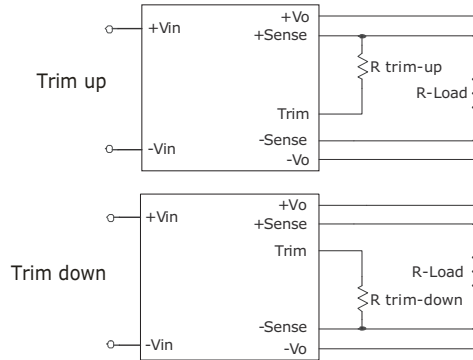

Table 1
Trim Up Resistor Values (M Ω)¹

Desired Vout (%Vout) Nom. Vout (Vdc)	101%	102%	103%	104%	105%
12	2.2	1.6	1.2	0.82	0.68
24	4.3	3.3	2.2	1.6	1.5
48	10	6.8	4.8	3.9	3.5

Table 2
Trim Down Resistor Values (K Ω)

Desired Vout (%Vout) Nom. Vout (Vdc)	90%	92%	94%	96%	98%
12	9	12	22	51	100
24	12	22	51	100	300
48	22	32	49	100	300

Note: 1. VFK400W-Q48-S12-DIN model requires minimum input voltage of 21.6 Vdc in order to trim between 100~105%.

Note: All specifications measured at 25°C, nominal input voltage, and full load unless otherwise noted.

REVISION HISTORY

rev.	description	date
1.0	initial release	01/03/2014
1.01	changed DIN-rail mount	06/16/2014

The revision history provided is for informational purposes only and is believed to be accurate.



CUI INC[®]

Headquarters
20050 SW 112th Ave.
Tualatin, OR 97062
800.275.4899

Fax 503.612.2383
cui.com
techsupport@cui.com

CUI offers a two (2) year limited warranty. Complete warranty information is listed on our website.

CUI reserves the right to make changes to the product at any time without notice. Information provided by CUI is believed to be accurate and reliable. However, no responsibility is assumed by CUI for its use, nor for any infringements of patents or other rights of third parties which may result from its use.

CUI products are not authorized or warranted for use as critical components in equipment that requires an extremely high level of reliability. A critical component is any component of a life support device or system whose failure to perform can be reasonably expected to cause the failure of the life support device or system, or to affect its safety or effectiveness.