

DRAWING FOR REFERENCE: This is subject to change without notice  
08/11/2012

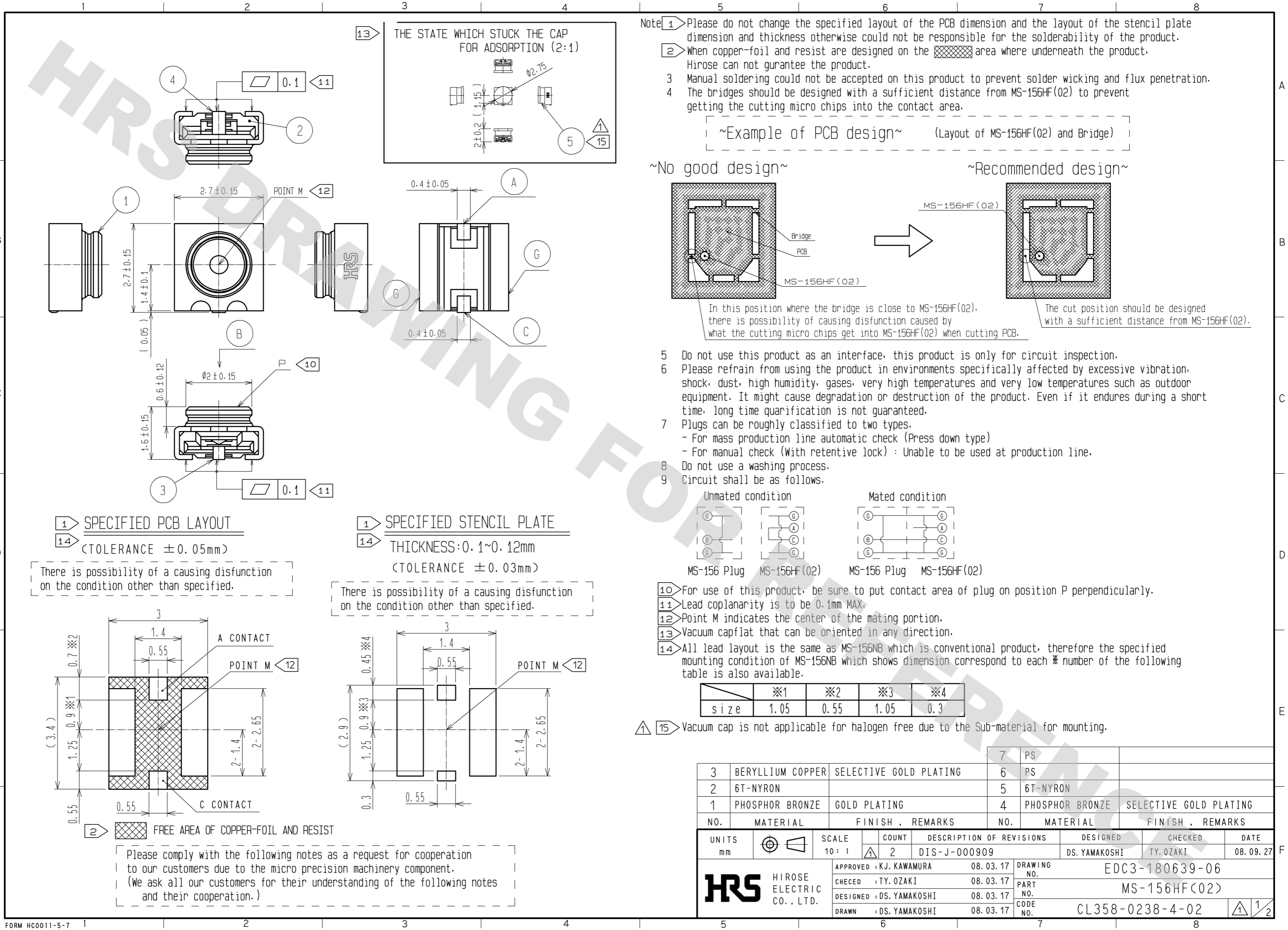

13 THE STATE WHICH STUCK THE CAP FOR ADSORPTION (2:1)

- Note 1 Please do not change the specified layout of the PCB dimension and the layout of the stencil plate dimension and thickness otherwise could not be responsible for the solderability of the product.
- 2 When copper-foil and resist are designed on the area where underneath the product, Hirose can not guarantee the product.
- 3 Manual soldering could not be accepted on this product to prevent solder wicking and flux penetration.
- 4 The bridges should be designed with a sufficient distance from MS-156HF(02) to prevent getting the cutting micro chips into the contact area.

~Example of PCB design~ (Layout of MS-156HF(02) and Bridge)

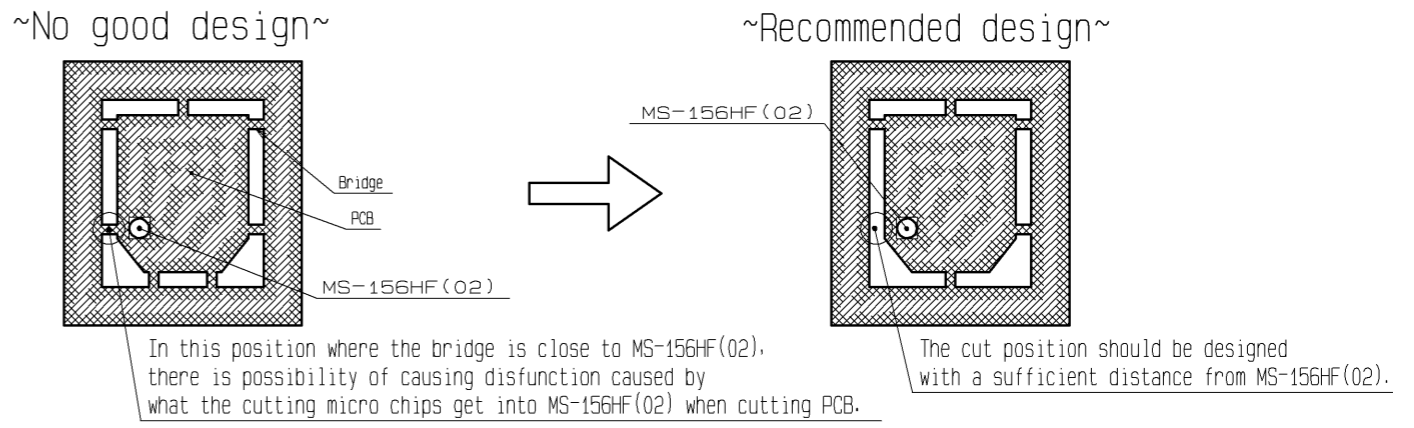

- 5 Do not use this product as an interface, this product is only for circuit inspection.
- 6 Please refrain from using the product in environments specifically affected by excessive vibration, shock, dust, high humidity, gases, very high temperatures and very low temperatures such as outdoor equipment. It might cause degradation or destruction of the product. Even if it endures during a short time, long time quarification is not guaranteed.
- 7 Plugs can be roughly classified to two types.  
- For mass production line automatic check (Press down type)  
- For manual check (With retentive lock) : Unable to be used at production line.
- 8 Do not use a washing process.
- 9 Circuit shall be as follows.

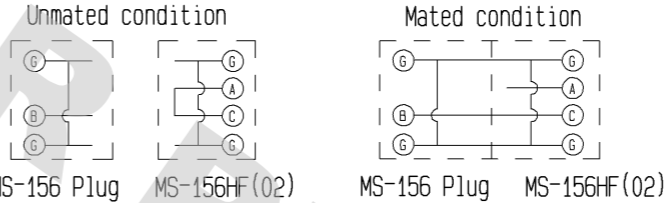

- 10 For use of this product, be sure to put contact area of plug on position P perpendicularly.
- 11 Lead coplanarity is to be 0.1mm MAX.
- 12 Point M indicates the center of the mating portion.
- 13 Vacuum capflat that can be oriented in any direction.
- 14 All lead layout is the same as MS-156NB which is conventional product, therefore the specified mounting condition of MS-156NB which shows dimension correspond to each \* number of the following table is also available.

	*1	*2	*3	*4
size	1.05	0.55	1.05	0.3

15 Vacuum cap is not applicable for halogen free due to the Sub-material for mounting.

1 SPECIFIED PCB LAYOUT  
14 TOLERANCE ±0.05mm

There is possibility of a causing disfunction on the condition other than specified.

1 SPECIFIED STENCIL PLATE  
14 THICKNESS:0.1~0.12mm  
TOLERANCE ±0.03mm

There is possibility of a causing disfunction on the condition other than specified.

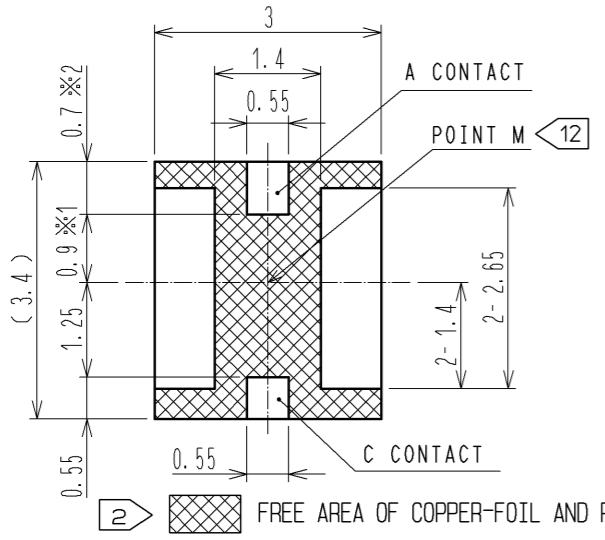

2 FREE AREA OF COPPER-FOIL AND RESIST

Please comply with the following notes as a request for cooperation to our customers due to the micro precision machinery component.  
(We ask all our customers for their understanding of the following notes and their cooperation.)

3	BERYLLIUM COPPER	SELECTIVE GOLD PLATING	7	PS	
2	6T-NYRON		6	PS	
1	PHOSPHOR BRONZE	GOLD PLATING	5	6T-NYRON	
			4	PHOSPHOR BRONZE	SELECTIVE GOLD PLATING
NO.	MATERIAL	FINISH . REMARKS	NO.	MATERIAL	FINISH . REMARKS
UNITS	mm	SCALE 10:1	COUNT	2	DESCRIPTION OF REVISIONS
APPROVED : KJ. KAWAMURA 08.03.17			DESIGNED : DS. YAMAKOSHI		
CHECKED : TY. OZAKI 08.03.17			CHECKED : TY. OZAKI		
DESIGNED : DS. YAMAKOSHI 08.03.17			DATE 08.09.27		
DRAWN : DS. YAMAKOSHI 08.03.17			DRAWING NO. EDC3-180639-06		
HRS HIROSE ELECTRIC CO., LTD.			PART NO. MS-156HF(02)		
			CODE NO. CL358-0238-4-02		

PACKAGING SPECIFICATION

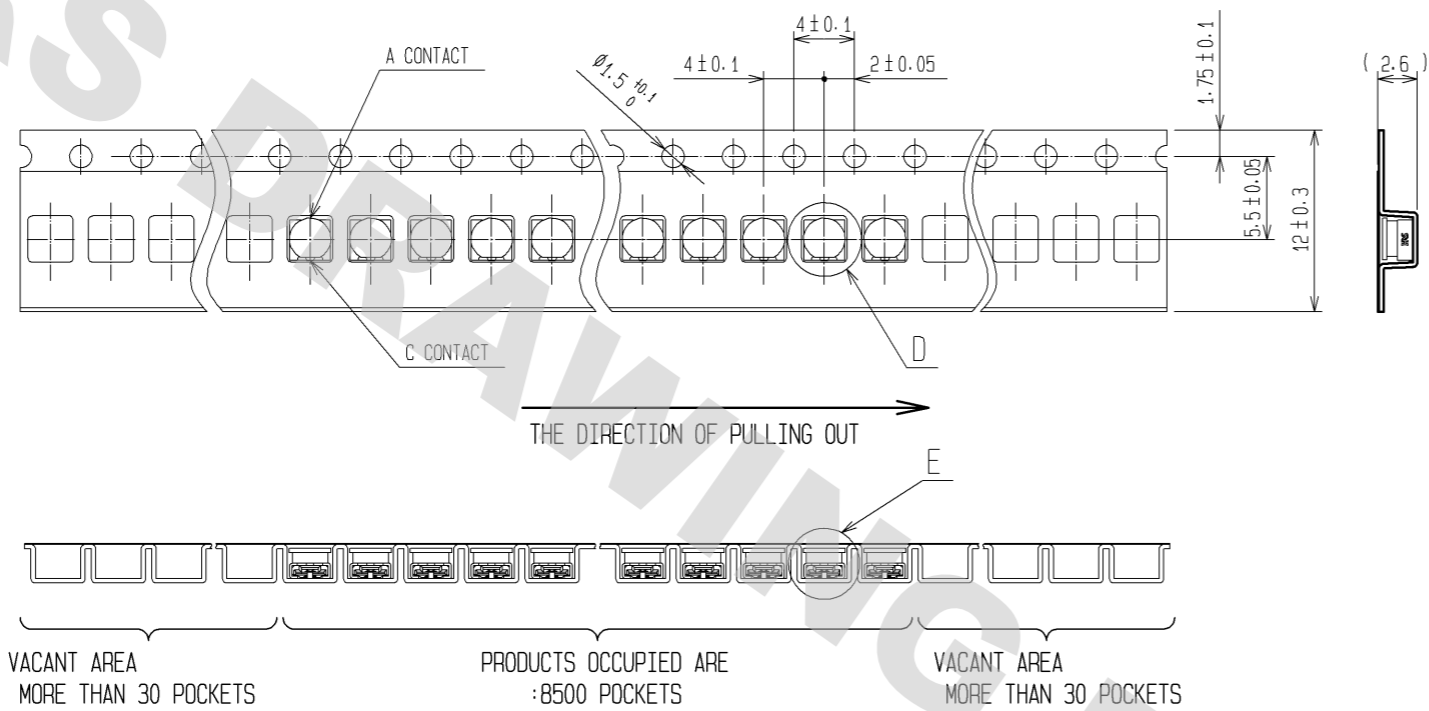

REEL DIMENSIONS(FREE)

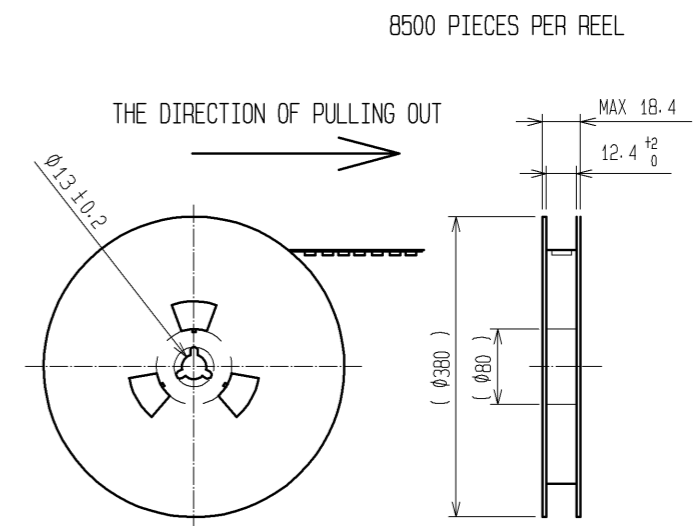

VACANT AREA MORE THAN 30 POCKETS      PRODUCTS OCCUPIED ARE :8500 POCKETS      VACANT AREA MORE THAN 30 POCKETS

D (10:1)

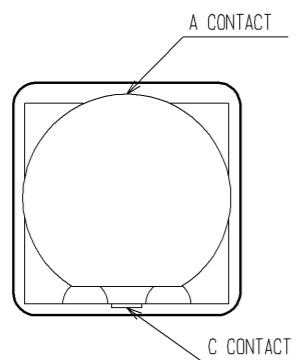

E (10:1)

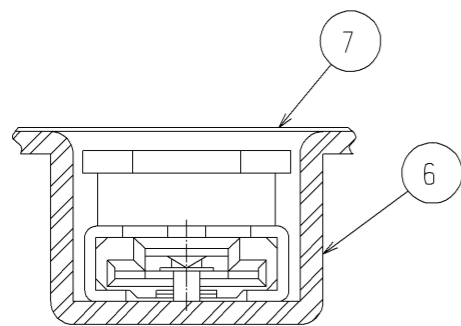

OUTER PACKAGING CASE (FREE)

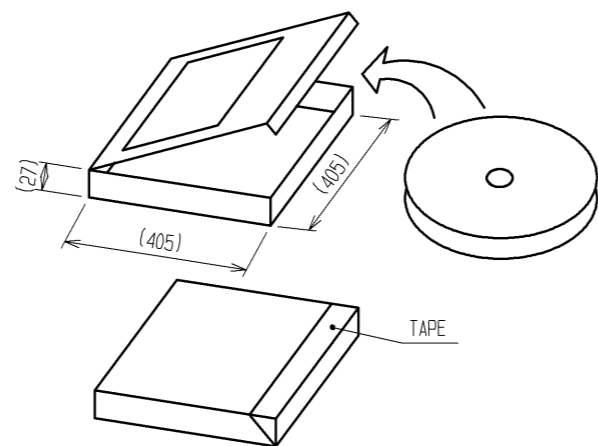

RECOMMENDED REFLOW TEMPERATURE PROFILE

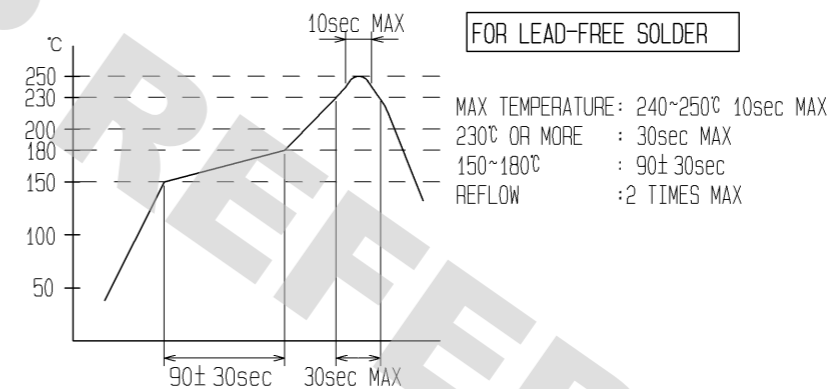

DRAWING FOR REFERENCE: This is subject to change without notice  
08/11/2012

UNITS mm		SCALE 2 : 1	COUNT △	DESCRIPTION OF REVISIONS DIS-J-000909	DESIGNED DS. YAMAKOSHI	CHECKED TY. OZAKI	DATE 08.09.27
APPROVED : KJ. KAWAMURA 08.03.17				DRAWING NO. EDC3-180639-06			
CHECKED : TY. OZAKI 08.03.17				PART NO. MS-156HF(02)			
DESIGNED : DS. YAMAKOSHI 08.03.17				CODE NO. CL358-0238-4-02			
DRAWN : DS. YAMAKOSHI 08.03.17				△ 2/2			