



# ITH08C06

## High Frequency Powerline N-Channel IGBT with Ultrafast Diode

Supersedes October 1998, version DS5044-1.2

DS5044-2.0 April 1999

The ITH08C06 is a robust n-channel, enhancement mode insulated gate bipolar transistor (IGBT) designed for low power dissipation in a wide range of high voltage applications such as power supplies and motor drives. The high impedance gate simplifies gate drive considerations, allowing operation directly from low power control circuitry.

Fast rise and fall times allow very high frequency switching making the device suitable for modern systems employing high frequency switching.

Low saturation voltages minimise power dissipation, thereby reducing the cost of the overall system in which they are used.

The ITS is fully short circuit rated making it especially suited for motor control and other applications requiring short circuit with stand capacity. Each device in the Powerline range is available with or without an integral anti-parallel ultrafast soft recovery diode, see separate datasheet for discrete device

Typical applications include high frequency inverters for motor control, welding and heating apparatus. The Powerline range of IGBTs is also applicable to switched mode and uninterruptible power supplies.

### Features

- Enhancement Mode n-Channel Device
- High Switching Speed
- Low On-state Saturation Voltage
- High Input Impedance Simplifies Gate Drive
- Latch-Free Operation
- Short Circuit Rated
- Integral Fast Recovery Diode

### Applications

- High Frequency Inverters
- Motor Control
- Switched Mode Power Supplies
- High Frequency Welding
- Heating/Cooking Apparatus

### Key Parameters

$V_{CES}$	(max)	600V
$V_{CE(sat)}$	(typ)	2.3V
$I_{C25}$	(max)	14A
$I_{C85}$	(max)	8A
$I_{CM}$	(max)	24A
$t_{sc}$	(max)	10 $\mu$ s

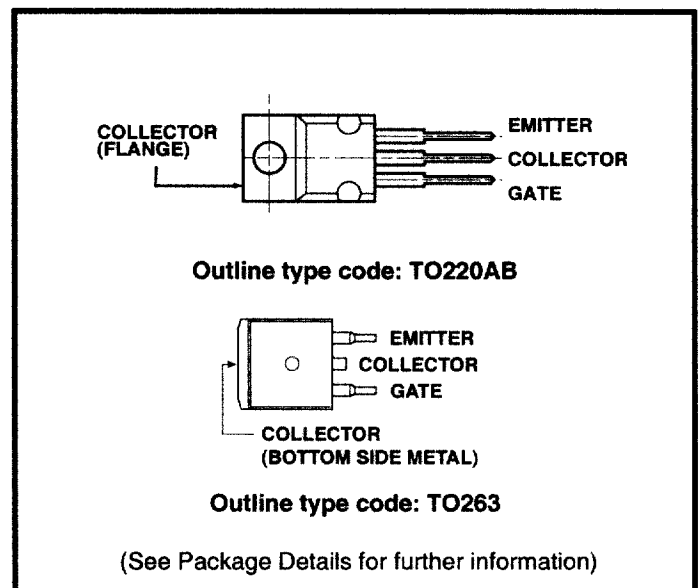

Fig.1 Pin connections - top view (not to scale)

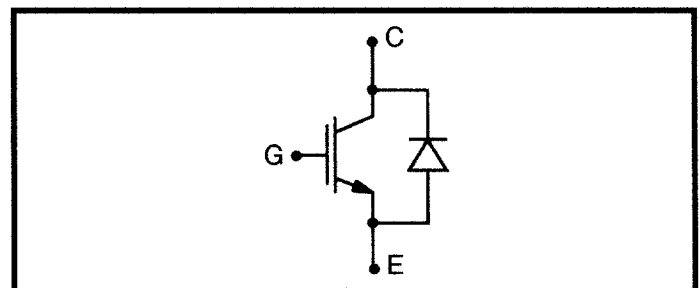

Fig.2 ITH08C06 circuit

### Ordering Information

Order as:

**ITH08C06B** TO220AB (with fast recovery diode)

**ITH08C06A** TO263 (D<sup>2</sup> PACK) (with fast recovery diode)

Note: When ordering use complete part number.

**Caution: These devices are sensitive to electrostatic discharge. Users should observe proper ESD handling precautions.**

## ITH08C06

### Absolute Maximum Ratings

Stresses above those listed under 'Absolute Maximum Ratings' may cause permanent damage to the device. This is a stress rating only and functional operation of the device at these or any other conditions above those indicated in the operational sections of this specification is not implied. Exposure to Absolute Maximum Ratings for extended periods may affect device reliability.

$T_{case} = 25^{\circ}\text{C}$  unless stated otherwise.

Symbol	Parameter	Test Conditions	Max.	Units
$V_{CES}$	Collector-emitter voltage	$V_{GE} = 0\text{V}$	600	V
$V_{GES}$	Gate-emitter voltage	-	$\pm 20$	V
$I_{C25}$	Continuous collector current	$T_{case} = 25^{\circ}\text{C}$	14	A
$I_{C85}$	Continuous collector current	$T_{case} = 85^{\circ}\text{C}$	8	A
$I_{CM}$	Pulsed collector current	1ms, $T_{case} = 85^{\circ}\text{C}$	24	A
$P_{tot}$	Power dissipation	$T_{case} = 85^{\circ}\text{C}$	30	W

### Thermal And Mechanical Ratings

Symbol	Parameter	Conditions	Min.	Max.	Units
$R_{th(j-c)}$	Thermal resistance - IGBT	DC junction to case	-	2.1	$^{\circ}\text{C/W}$
$R_{th(j-c)}$	Thermal resistance - Diode	DC junction to case	-	3.0	$^{\circ}\text{C/W}$
$T_j$	Operating junction temperature range	-	-40	150	$^{\circ}\text{C}$
$T_{stg}$	Storage temperature range	-	-40	150	$^{\circ}\text{C}$
-	Mounting torque	M3 Screw	-	1.1	Nm

### DC Electrical Characteristics

$T_{case} = 25^{\circ}\text{C}$  unless stated otherwise.

Symbol	Parameter	Conditions	Min.	Typ.	Max.	Units
$I_{CES}$	Collector cut-off current	$V_{GE} = 0\text{V}, V_{CE} = 600\text{V}$	-	-	0.25	mA
$I_{GES}$	Gate leakage current	$V_{GE} = 20\text{V}, V_{CE} = 0\text{V}$	-	-	$\pm 500$	nA
$V_{GE(TH)}$	Gate threshold voltage	$I_C = 0.25\text{mA}, V_{CE} = V_{GE}$	4.5	6	7.5	V
$V_{CE(SAT)}$	Collector-emitter saturation voltage	$V_{GE} = 15\text{V}, I_C = 8\text{A}$	-	2.3	2.9	V
		$V_{GE} = 15\text{V}, I_C = 8\text{A}, T_j = 125^{\circ}\text{C}$	-	2.5	-	V

**AC Electrical Characteristics**

$T_{case} = 25^{\circ}C$  unless stated otherwise.

Symbol	Parameter	Conditions	Min.	Typ.	Max.	Units
$C_{ies}$	Input capacitance	$V_{CE} = 25V, V_{GE} = 15V, f = 1MHz$	-	835	-	pF
$C_{oes}$	Output capacitance	$V_{CE} = 25V, V_{GE} = 15V, f = 1MHz$	-	72.5	-	pF
$C_{res}$	Reverse transfer capacitance	$V_{CE} = 25V, V_{GE} = 15V, f = 1MHz$	-	7.6	-	pF

**Inductive Switching Characteristics**

$T_{case} = 25^{\circ}C$  unless stated otherwise.

Symbol	Parameter	Conditions	Min.	Typ.	Max.	Units
$t_{d(ON)}$	Turn-on delay time	$I_C = 8A$ $V_{GE} = 15V,$ $V_{CE} = 50\%V_{ces}$ $R_{G(ON)} = R_{G(OFF)} = 5\Omega$	-	75	-	ns
$t_r$	Rise time		-	25	-	ns
$E_{ON}$	Turn-on energy loss - per cycle		-	110	-	$\mu J$
$t_{d(OFF)}$	Turn-off delay time		-	110	-	ns
$t_f$	Fall time		-	150	300	ns
$E_{OFF}$	Turn-off energy loss - per cycle		-	230	-	$\mu J$

$T_{case} = 125^{\circ}C$  unless stated otherwise.

Symbol	Parameter	Conditions	Min.	Typ.	Max.	Units
$t_{d(ON)}$	Turn-on delay time	$I_C = 8A$ $V_{GE} = 15V,$ $V_{CE} = 50\%V_{ces}$ $R_{G(ON)} = R_{G(OFF)} = 5\Omega$	-	75	-	ns
$t_r$	Rise time		-	25	-	ns
$E_{ON}$	Turn-on energy loss - per cycle		-	200	-	$\mu J$
$t_{d(OFF)}$	Turn-off delay time		-	120	-	ns
$t_f$	Fall time		-	290	-	ns
$E_{OFF}$	Turn-off energy loss - per cycle		-	360	-	$\mu J$

**Short Circuit Rating**

$T_{case} = 125^{\circ}C$  unless stated otherwise.

Symbol	Parameter	Conditions	Min.	Typ.	Max.	Units
$t_{sc}$	Short circuit withstand time	$V_{GE} = 15V, V_{CE} = 50\% V_{CES}$	-	-	10	$\mu s$

Caution: These devices are sensitive to electrostatic discharge. Users should observe proper ESD handling precautions.

# ITH08C06

## Diode Characteristics

$T_c = 25^\circ\text{C}$  unless stated otherwise

Symbol	Parameter	Conditions	Min.	Typ.	Max.	Units
$V_{FM}$	Forward voltage	At $I_F = 8\text{A}$ peak	-	1.3	-	V
		At $I_F = 8\text{A}$ peak, $T_{case} = 125^\circ\text{C}$	-	1.2	-	V
$t_{rr}$	Reverse recovery time	$I_F = 8\text{A}$ , $di_{RR}/dt = 200\text{A}/\mu\text{s}$ ,	-	50	-	ns
$I_{RRM}$	Reverse recovery current	$V_R = 50\% V_{RRM}$	-	7	-	A

## Basic Test Circuit

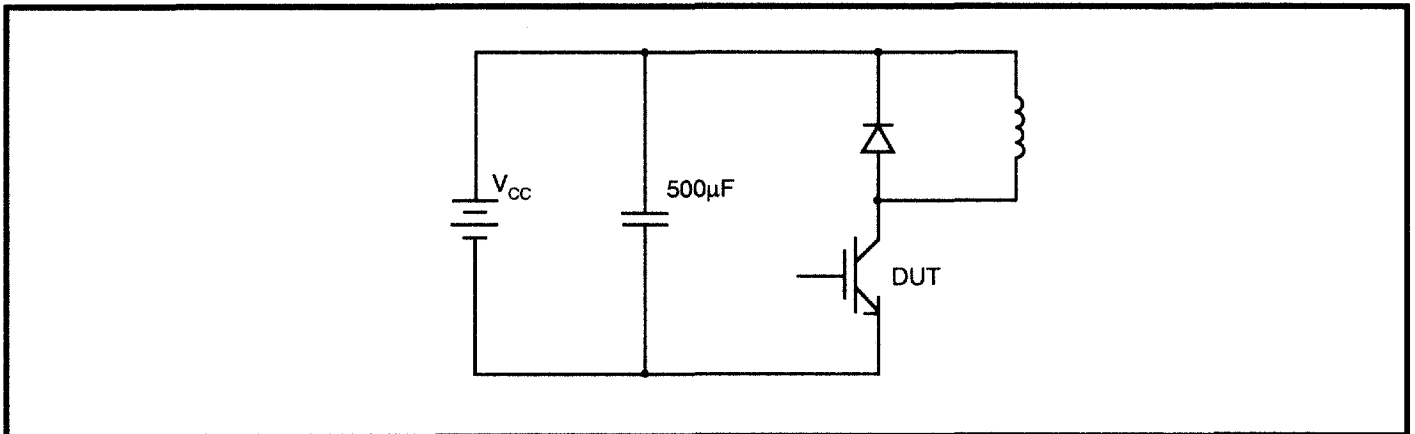

Fig.3 Basic d.c. chopper circuit

Switching Definitions

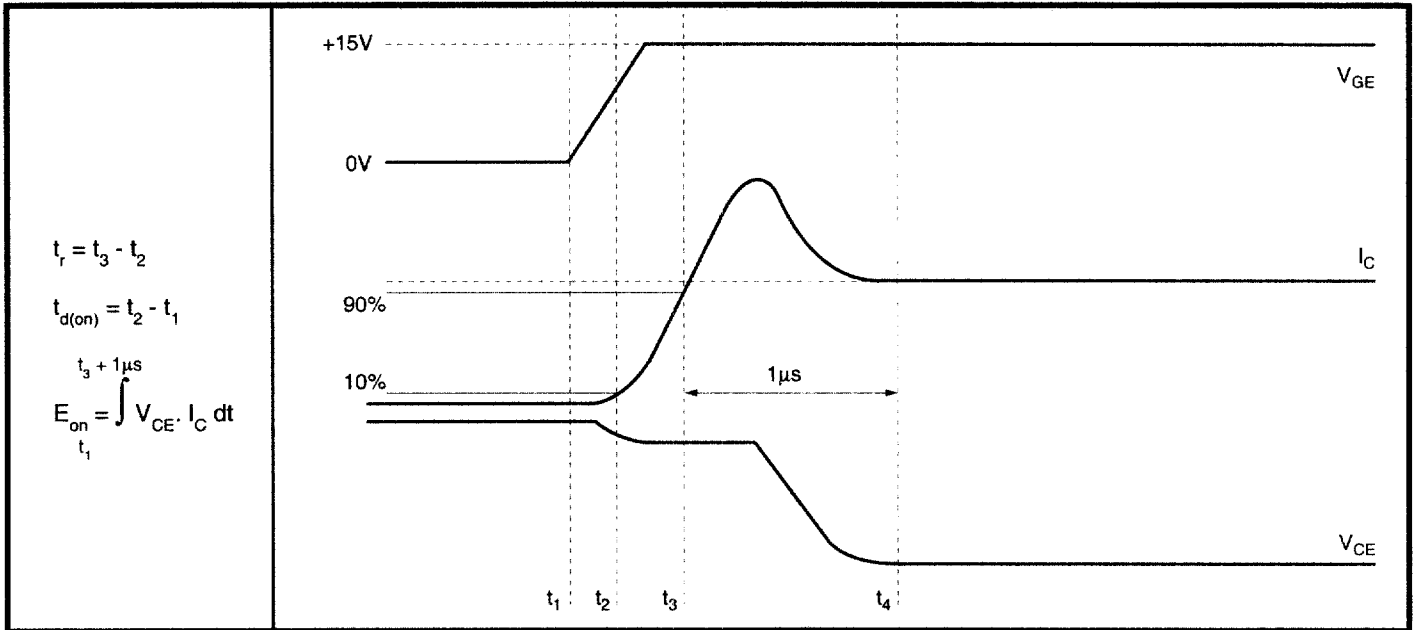

Fig.4 Turn-on characteristics

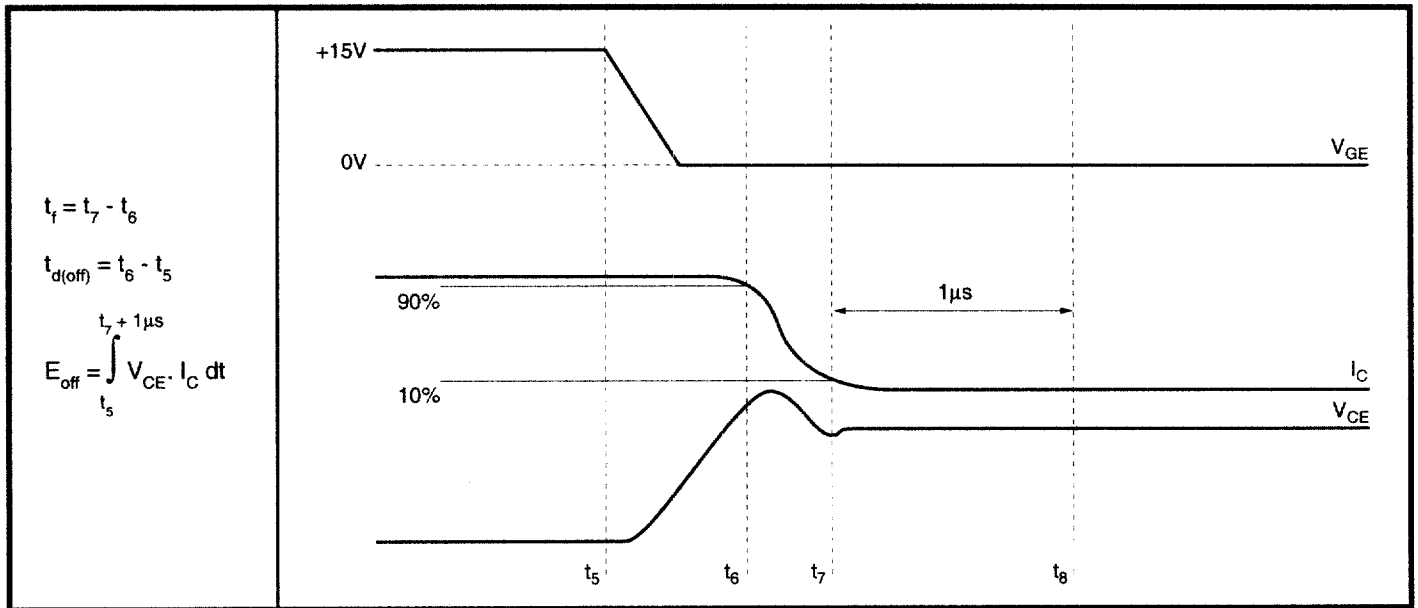

Fig.5 Turn-off characteristics

Curves

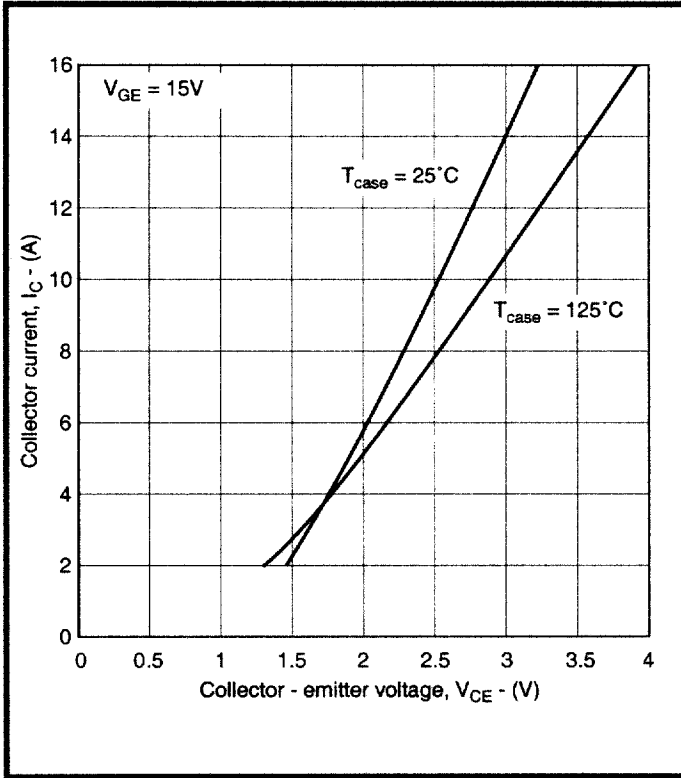

Fig.6 Typical output characteristics

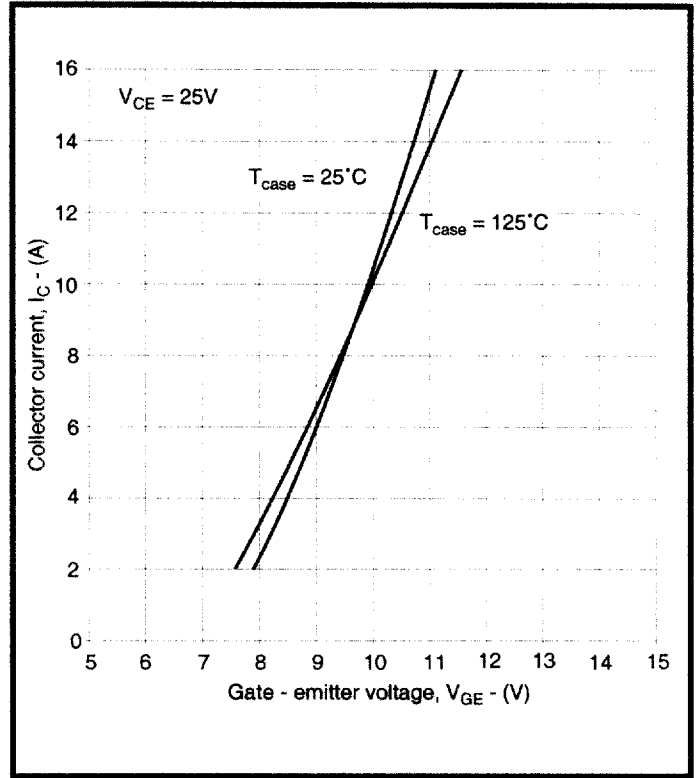

Fig.7 Typical transfer characteristics

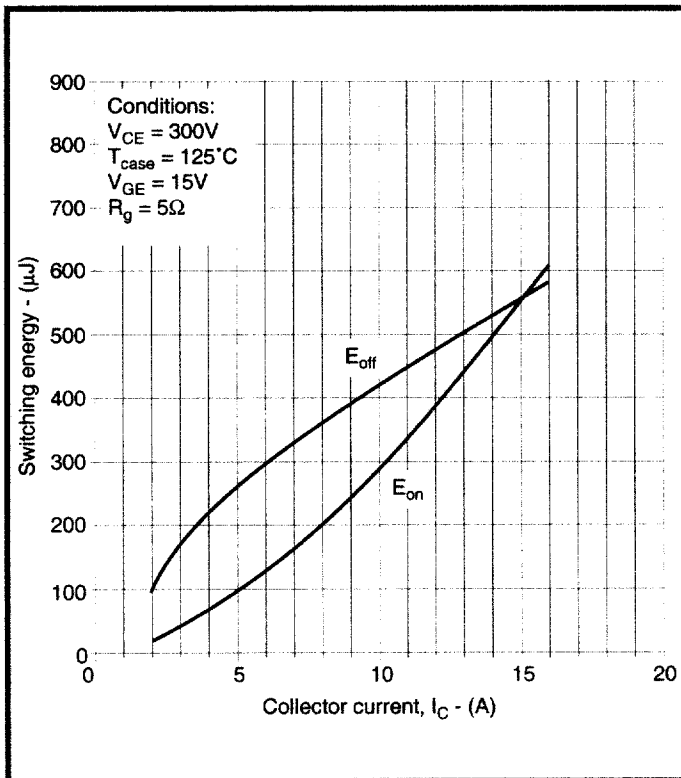

Fig.8 Typical switching losses vs collector current

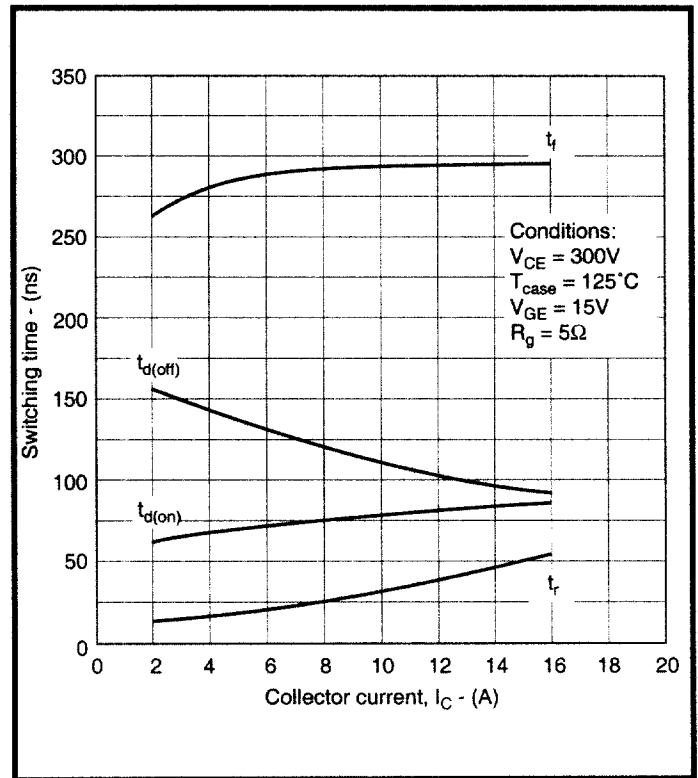

Fig.9 Typical switching times vs collector current

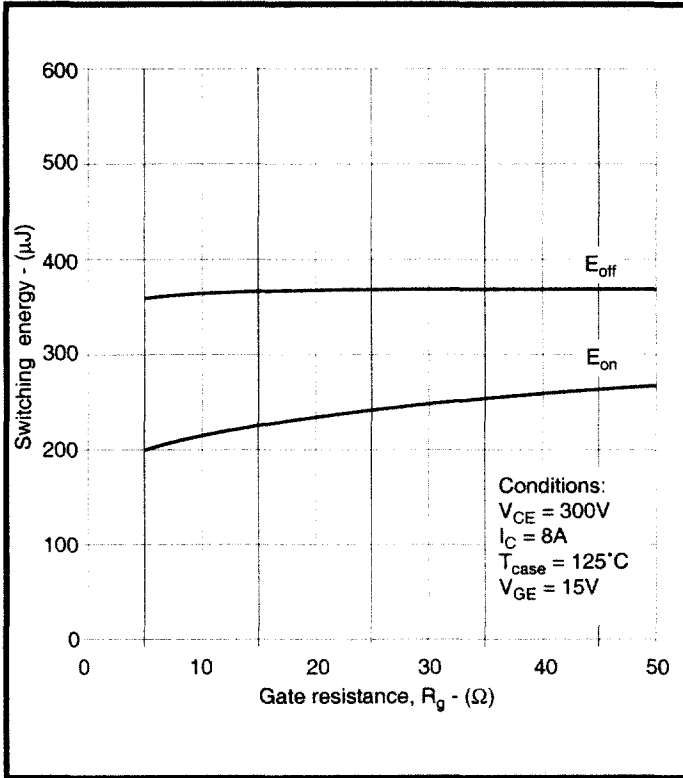

Fig.10 Typical switching losses vs gate resistance

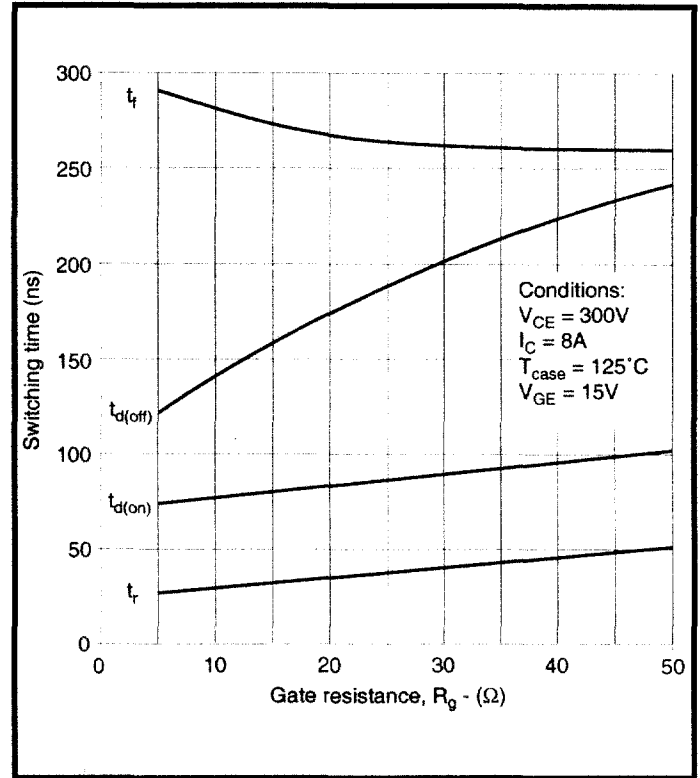

Fig.11 Typical switching times vs gate resistance

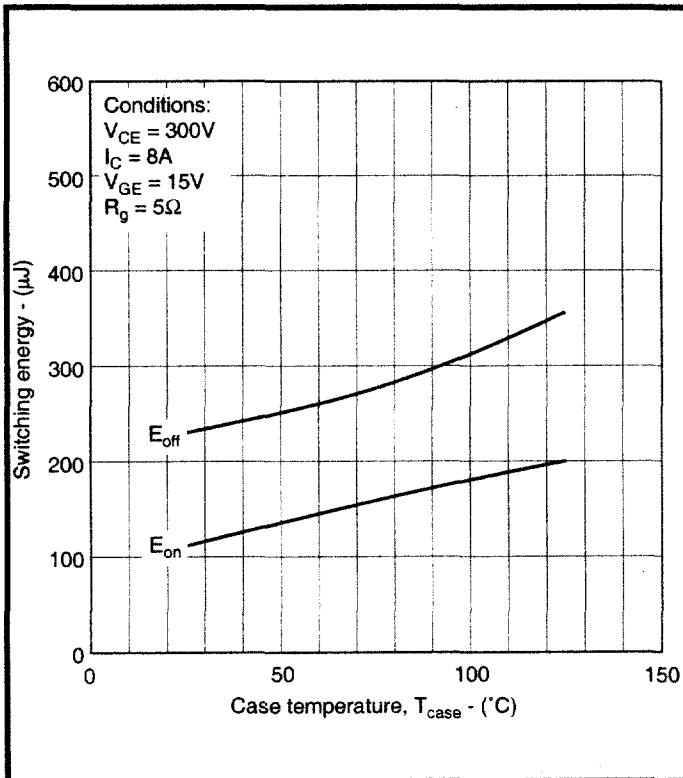

Fig.12 Typical switching losses vs case temperature

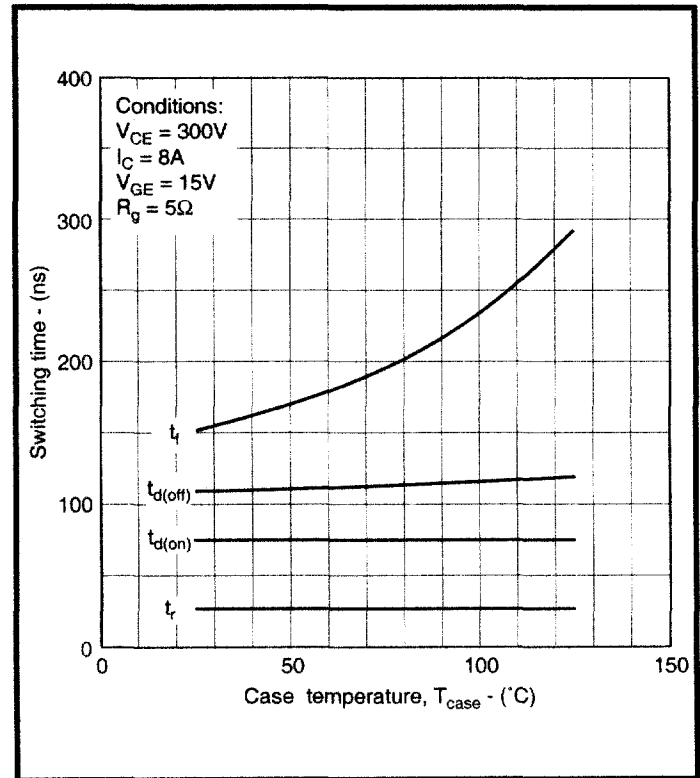

Fig.13 Typical switching times vs case temperature

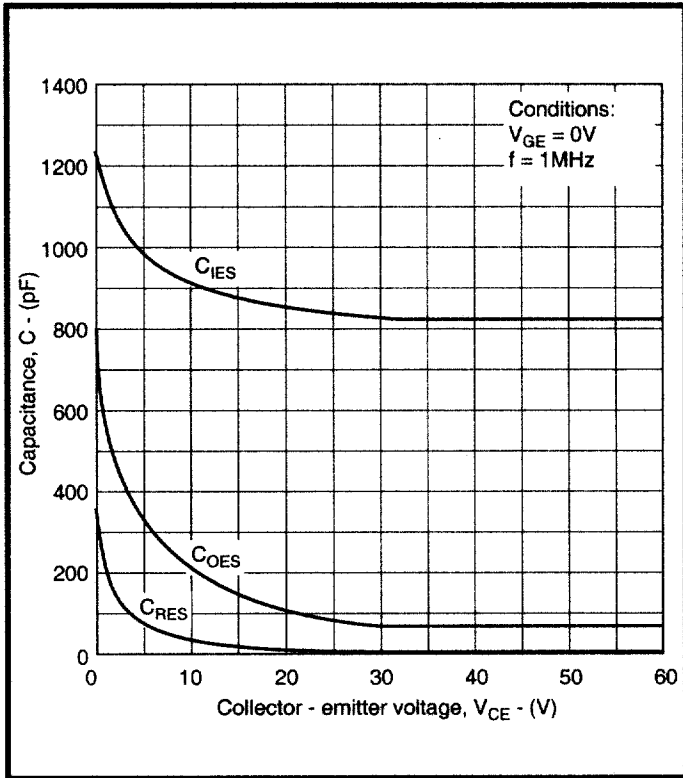

Fig.14 Typical capacitance

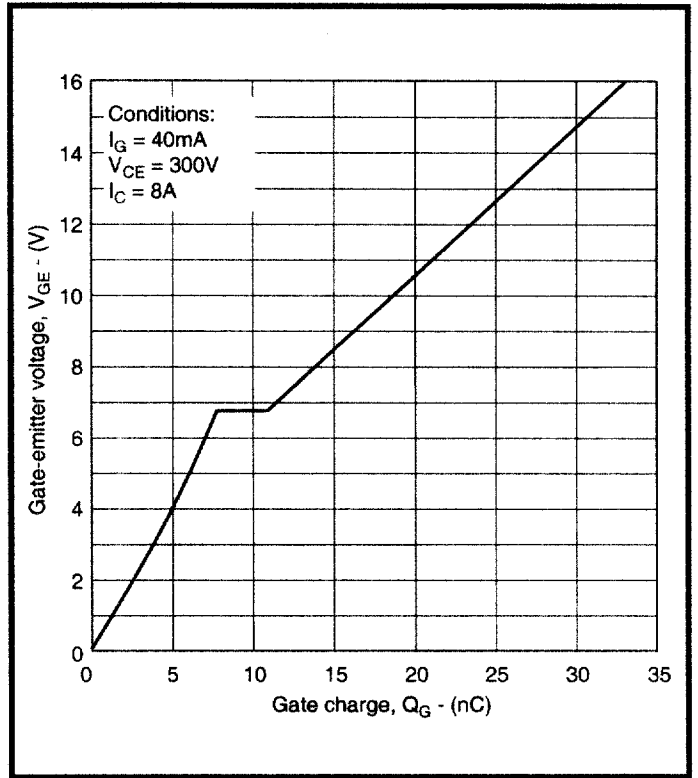

Fig.15 Typical gate charge

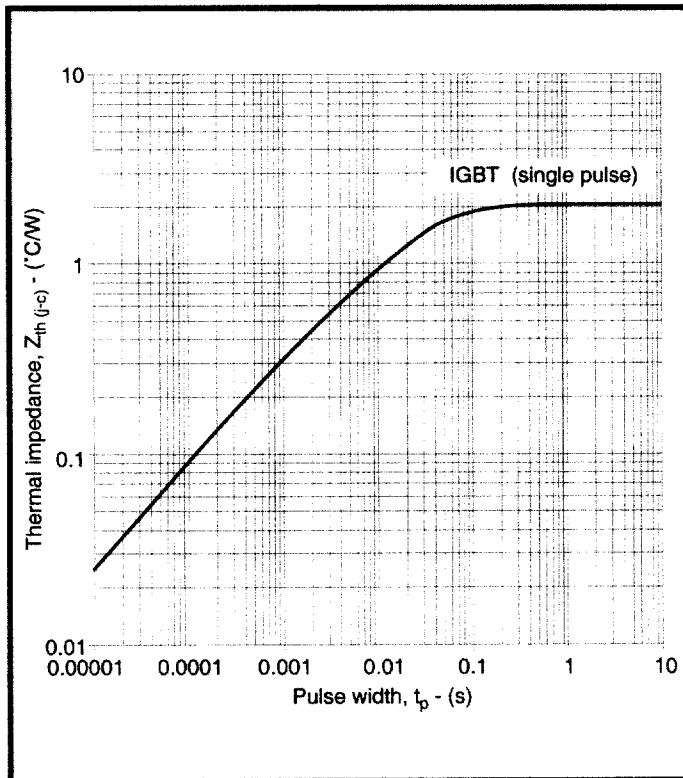

Fig.16 Transient thermal impedance - junction to case

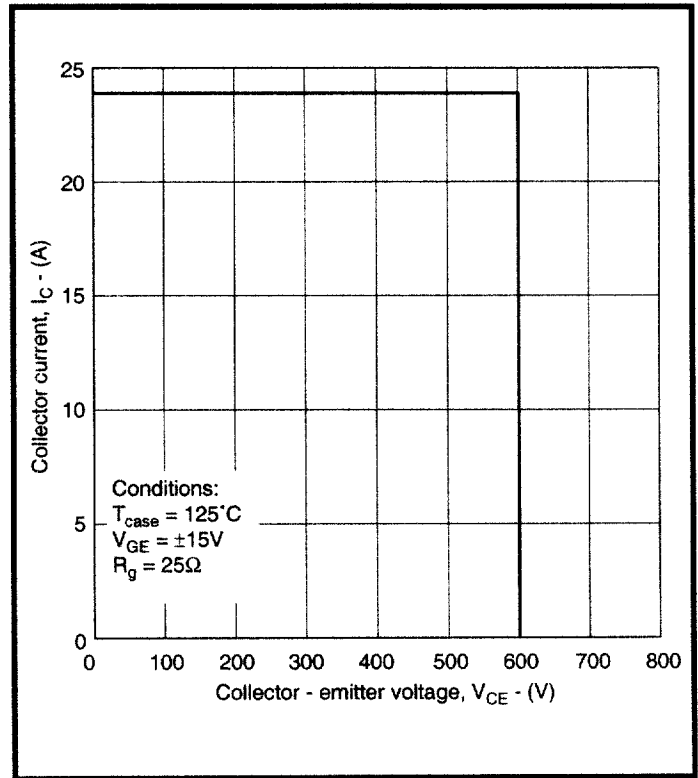

Fig.17 Reverse bias safe operating area

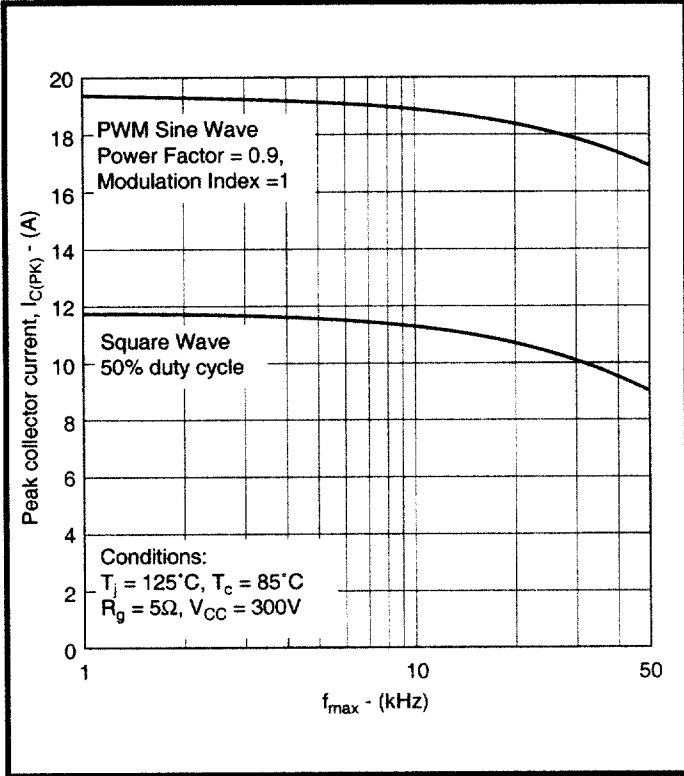

Fig.18 Three phase PWM inverter operating frequency

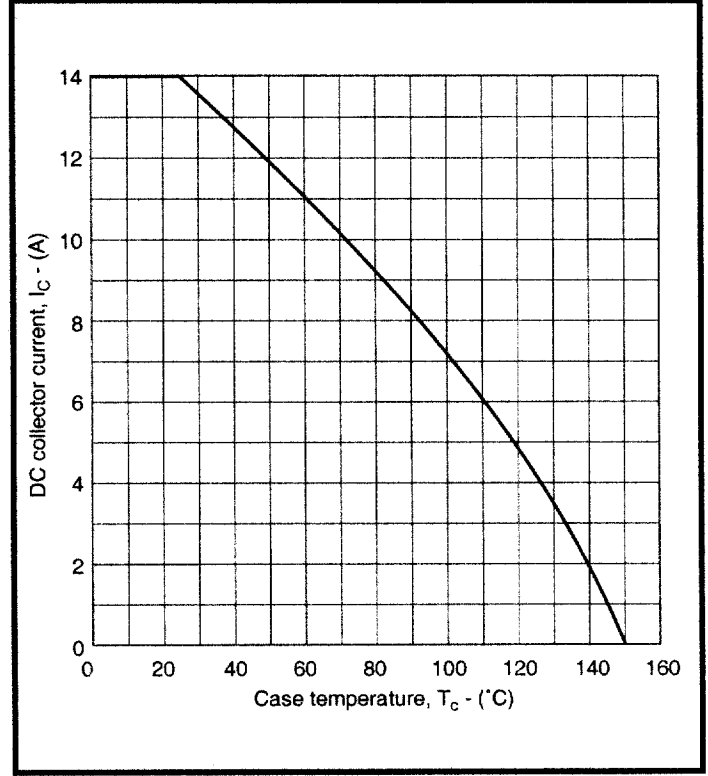

Fig.19 Collector current vs case temperature

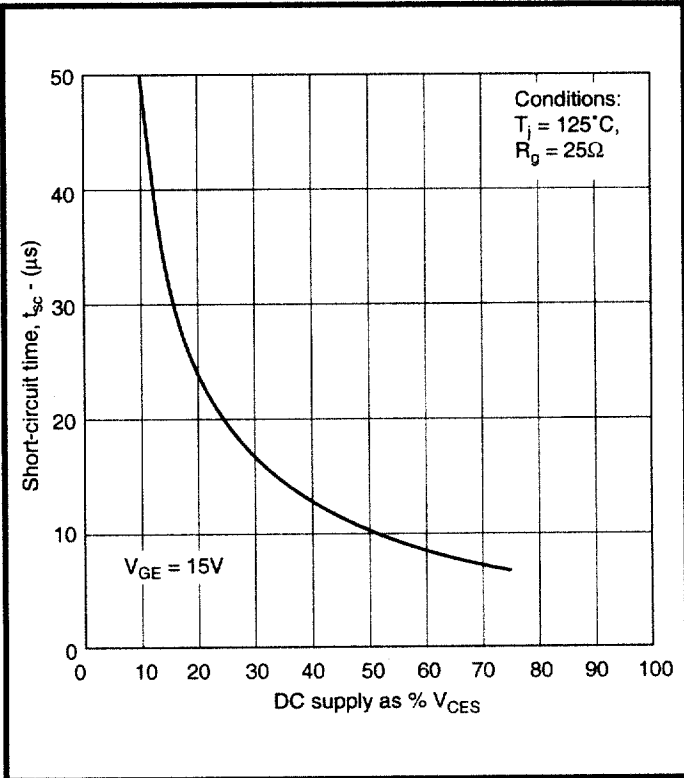

Fig.20 Short circuit withstand

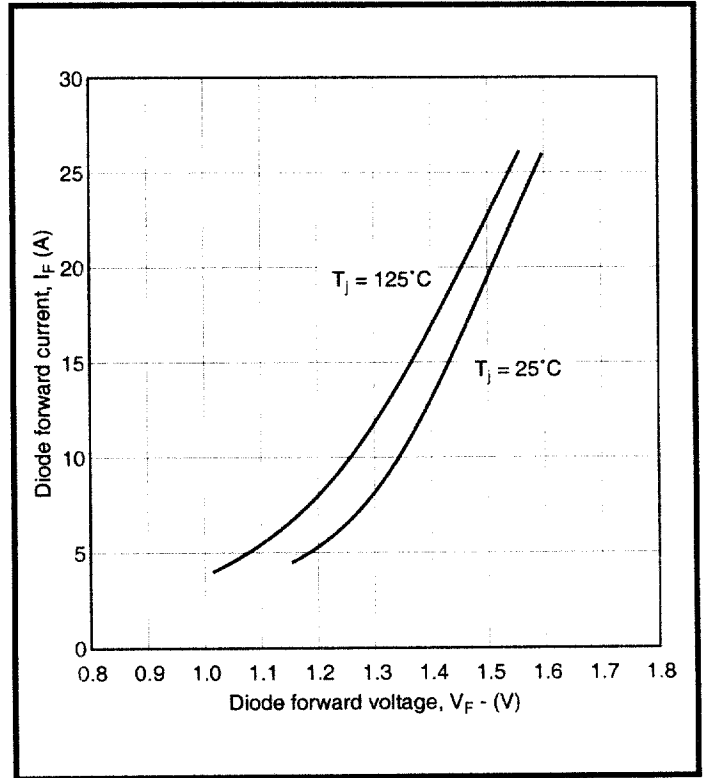
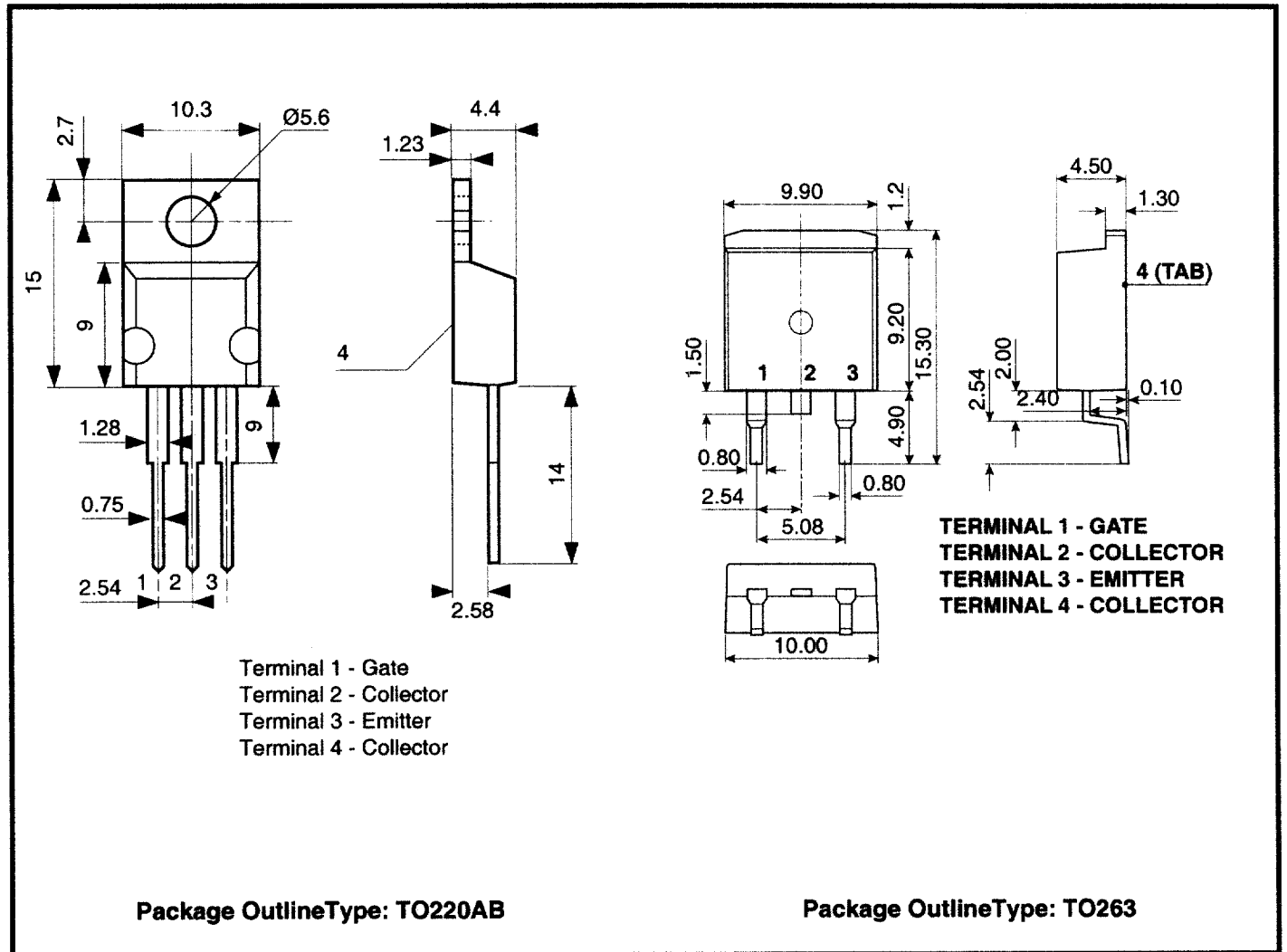

Fig.21 Diode typical forward characteristics

# ITH08C06

## Package Details

For additional package information, please contact your nearest representative or Mitel Semiconductor Customer Service Centre. All dimensions in mm, unless stated otherwise. DO NOT SCALE.





<http://www.mitelsemi.com>

e-mail: [power\\_solutions@mitel.com](mailto:power_solutions@mitel.com)

**Power Headquarters - United Kingdom**

Tel: +44 (0)1522 500500

Fax: +44 (0)1522 500550

**North America**

Tel: 011-800-5554-5554

Fax: 011-800-5444-5444

**UK, Germany, Rest Of World**

Tel: +44 (0)1522 500500

Fax: +44 (0)1522 500020

**France, Benelux and Spain**

Tel: +33 (0)1 69 18 90 00

Fax: +33 (0)1 64 46 54 50

Information relating to products and circuits ("Product") furnished herein by Mitel Corporation or its subsidiaries ("Mitel") is believed to be reliable. However, Mitel assumes no liability for errors that may appear in this document, or for liability otherwise arising from the application or use of any such information or Product or for any infringement of patents or other intellectual property rights owned by third parties which may result from such application or use. Neither the supply of such information or the purchase of Product conveys any license, either expressed or implied, under patents or other intellectual property rights owned by Mitel or licensed from third parties by Mitel, whatsoever. Purchasers of Products are also hereby notified that the use of Product in certain ways or in combination with Mitel or non-Mitel furnished goods or services may infringe patents or intellectual property rights owned by Mitel. The Products, their specifications and the information appearing in the document are subject to change by Mitel without notice.

M Mitel (design) is a registered trademark of MITEL Corporation

Mitel Semiconductor is an ISO 9001 Registered Company

Copyright 1999 MITEL Corporation

All Rights Reserved

Printed in 1999

Publication No. DS5044-2 Issue No 2.0 April 1999 TECHNICAL DOCUMENTATION – NOT FOR RESALE.