

L-BAND DPDT MMIC SWITCH

DESCRIPTION

The μPG139GV is L-Band Double Pole, Double Throw (DPDT) switch developed for digital cellular or cordless telephone and PCS applications. This device feature low insertion loss, high handling power with low voltage operation. It is housed in a very small 8-pin plastic SSOP package available on tape-and-reel and easy to install and contributes to miniaturizing the systems.

FEATURES

- High-Power Switching : Pin(1 dB) = +34 dBm typ. @ANT1, 2-TX, V_{DD} = 3.0 V, V_{CONT} = 3.6 V, f = 100 M to 2 GHz
Pin(0.5 dB) = +36 dBm typ. @ANT1, 2-TX, V_{DD} = 5.0 V, V_{CONT} = 5.0 V, f = 100 M to 2 GHz
- ★ ○ Low Insertion Loss : Lins1 = 0.70 dB typ. @ANT1, 2-TX, V_{DD} = 3.0 V, V_{CONT} = 3.6 V, f = 1 GHz
Lins4 = 0.85 dB typ. @ANT1, 2-RX, V_{DD} = 3.0 V, V_{CONT} = 3.6 V, f = 1 GHz
- Small 8-pin SSOP (175 mil) Package

APPLICATION

- Digital Cellular: PDC, GSM, IS-95, IS-136 etc.
- PCS, PHS Base station etc.

ORDERING INFORMATION

Part Number	Package	Packing Form
μPG139GV-E1	8-pin SSOP (175 mil)	Carrier tape width is 12 mm, Quantity is 2 kpcs per reel.

Remark For sample order, please contact your local NEC sales office. (Part number for sample order: μPG139GV)

Caution The IC must be handled with care to prevent static discharge because its circuit composed of GaAs MESFET.

The information in this document is subject to change without notice.

ABSOLUTE MAXIMUM RATINGS (TA = 25°C)

Parameters	Symbol	Conditions	Ratings	Unit
Supply Voltage	V _{DD}		V _{CONT} (H)	V
Control Voltage 1, 2	V _{CONT1,2}		-6.0 to +6.0 ^{Note1}	V
Input Power (ANT1, 2-TX)	P _{in}	V _{CONT} = +5 V/0 V	+36	dBm
Input Power (ANT1, 2-RX)	P _{in}	V _{CONT} = +5 V/0 V	+34	dBm
Input Power (ANT1, 2-TX)	P _{in}	V _{CONT} = +3 V/0 V	+34	dBm
Input Power (ANT1, 2-RX)	P _{in}	V _{CONT} = +3 V/0 V	+32	dBm
Total Power Dissipation	P _{tot}		0.7 ^{Note2}	W
Operating Temperature	T _A		-50 to +80	°C
Storage Temperature	T _{stg}		-65 to +150	°C

Notes 1. $2.7\text{ V} \leq |V_{\text{CONT1}} - V_{\text{CONT2}}| \leq 6.0$

2. Mounted on a 50 × 50 × 1.6 mm double copper clad epoxy glass PWB, T_A = +85 °C

PIN CONNECTION (Top View)

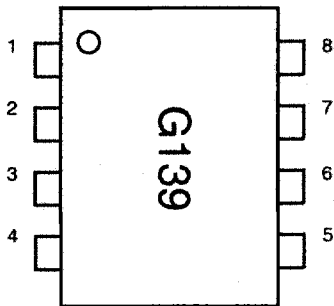

Pin No.	Connection	Pin No.	Connection
1	TX	5	RX
2	V _{DD}	6	V _{CONT1}
3	V _{CONT2}	7	GND
4	ANT2	8	ANT1

★ SWITCH IC SERIES PRODUCTS

Part Number	Pin (1 dB) (dBm)	LINS (dB)	ISL (dB)	V _{CONT} (V)	Package	Application
μPG130G	+34	0.5@1G	32@1G	-5/0	8-pin SSOP (175 mil)	PDC, IS-136, PHS
μPG131G	+30	0.6@2G	23@2G	-4/0		PHS, PCS, WLAN
μPG132G	+30	0.6@2G	22@2G	+3/0		PHS, PCS, WLAN
μPG133G	+25	0.6@2G	20@2G	-3/0		DIVERSITY, VCO
μPG137GV	+34	0.55@1G	25@2G	+3/0		PDC, GSM, IS-136
μPG138GV	+34 +37	0.55@1G	30@1G	-3/0 -5/0		PDC, GSM, IS-136
μPG139GV (ANT1, 2-TX)	+34	1.20@2G	12.5@2G	+3.6/0		PDC, IS-95, IS-136
μPG139GV (ANT1, 2-RX)	+30	1.00@2G	14@2G	+3.6/0		PDC, IS-95, IS-136

Remark As for detail information of series products, please refer to each data sheet.

RECOMMENDED OPERATING CONDITIONS (TA = 25°C)

Parameters	Symbol	MIN.	TYP.	MAX.	Unit
Control Voltage (High)	V _{CONT(H)}	+2.7	+3.6	+5.3	V
Control Voltage (Low)	V _{CONT(L)}	-0.2	0	+0.2	V
Supply Voltage	V _{DD}	V _{CONT(H)} - 0.7	V _{CONT(H)} - 0.6	V _{CONT(H)} - 0.5	V
Input Power (ANT1, 2-TX, V _{CONT} = +5 V)	P _{in}			+36	dBm
Input Power (ANT1, 2-RX, V _{CONT} = +5 V)	P _{in}			+33	dBm
Input Power (ANT1, 2-TX, V _{CONT} = +3 V)	P _{in}			+33	dBm
Input Power (ANT1, 2-RX, V _{CONT} = +3 V)	P _{in}			+31	dBm

★

ELECTRICAL CHARACTERISTICS

(Unless otherwise specified, TA = 25°C, V_{CONT} = +3.6 V/0 V, V_{DD} = +3.0 V, Z_S = Z_L = 50 Ω)

Parameters	Symbol	Test Conditions	MIN.	TYP.	MAX.	Unit
Insertion Loss 1	L _{INS1}	ANT1, 2-TX, f = 100 M to 1 GHz		0.70	0.85	dB
Insertion Loss 2	L _{INS2}	ANT1, 2-TX, f = 1.5 GHz		0.90	1.00	dB
Insertion Loss 3	L _{INS3}	ANT1, 2-TX, f = 2 GHz		1.20	1.30	dB
Insertion Loss 4	L _{INS4}	ANT1, 2-RX, f = 100 M to 1 GHz		0.85	0.95	dB
Insertion Loss 5	L _{INS5}	ANT1, 2-RX, f = 1.5 GHz		1.05	1.15	dB
Insertion Loss 6	L _{INS6}	ANT1, 2-RX, f = 2 GHz		1.30	1.40	dB
Isolation 1	ISL1	ANT1, 2-TX, f = 100 M to 1.5 GHz	13.5	15.5		dB
Isolation 2	ISL2	ANT1, 2-TX, f = 2 GHz	10.5	12.5		dB
Isolation 3	ISL3	ANT1, 2-RX, f = 100 M to 1.5 GHz	13.5	15.5		dB
Isolation 4	ISL4	ANT1, 2-RX, f = 2 GHz	10.5	12.5		dB
Input Return Loss	RL _{in}	f = 100 M to 2 GHz	11	15		dB
Output Return Loss	RL _{out}	f = 100 M to 2 GHz	11	15		dB
1 dB Compression Point ^{Note}	P _{in(1 dB)1}	ANT1, 2-TX, f = 100 M to 2 GHz	+32	+34		dBm
1 dB Compression Point ^{Note}	P _{in(1 dB)2}	ANT1, 2-RX, f = 100 M to 2 GHz	+27	+30		dBm
Input Power at 0.5 dB Compression Point ^{Note}	P _{in(0.5 dB)3}	ANT1, 2-TX, f = 100 M to 2 GHz V _{CONT} = +5 V/0 V V _{DD} = +5.0 V		+36		dBm
Input Power at 0.5 dB Compression Point ^{Note}	P _{in(0.5 dB)4}	ANT1, 2-RX, f = 100 M to 2 GHz V _{CONT} = +5 V/0 V V _{DD} = +5.0 V		+33		dBm
Control Current	I _{CONT}	RF OFF		15	50	μA
Switching Speed	t _{sw}			60		nS

Note Pin (1 dB) and Pin (0.5 dB) are measured the input power level when the insertion loss increase more 1 dB or 0.5 dB than that of linear range. All other characteristics are measured in linear range.

EVALUATION CIRCUIT

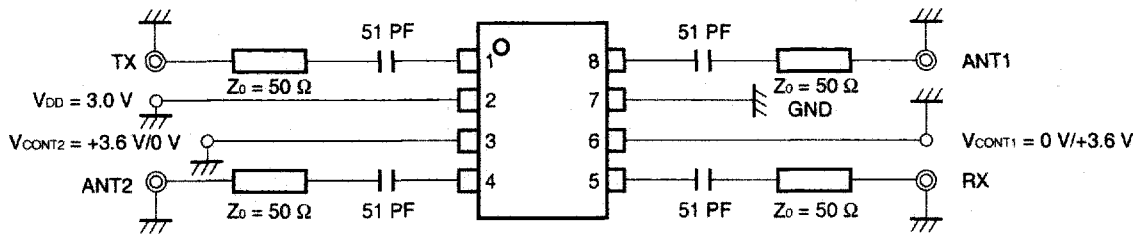

SWITCH LOGIC TABLES

V _{CONT1}	V _{CONT2}	Switching Portes
Low	High	ANT1-RX ON, ANT2-TX ON ANT1-TX OFF, ANT2-RX OFF
High	Low	ANT1-TX ON, ANT2-RX ON ANT1-RX OFF, ANT2-TX OFF

PACKAGE DIMENSIONS

8 PIN PLASTIC SHRINK SOP (175 mil) (Unit: mm)

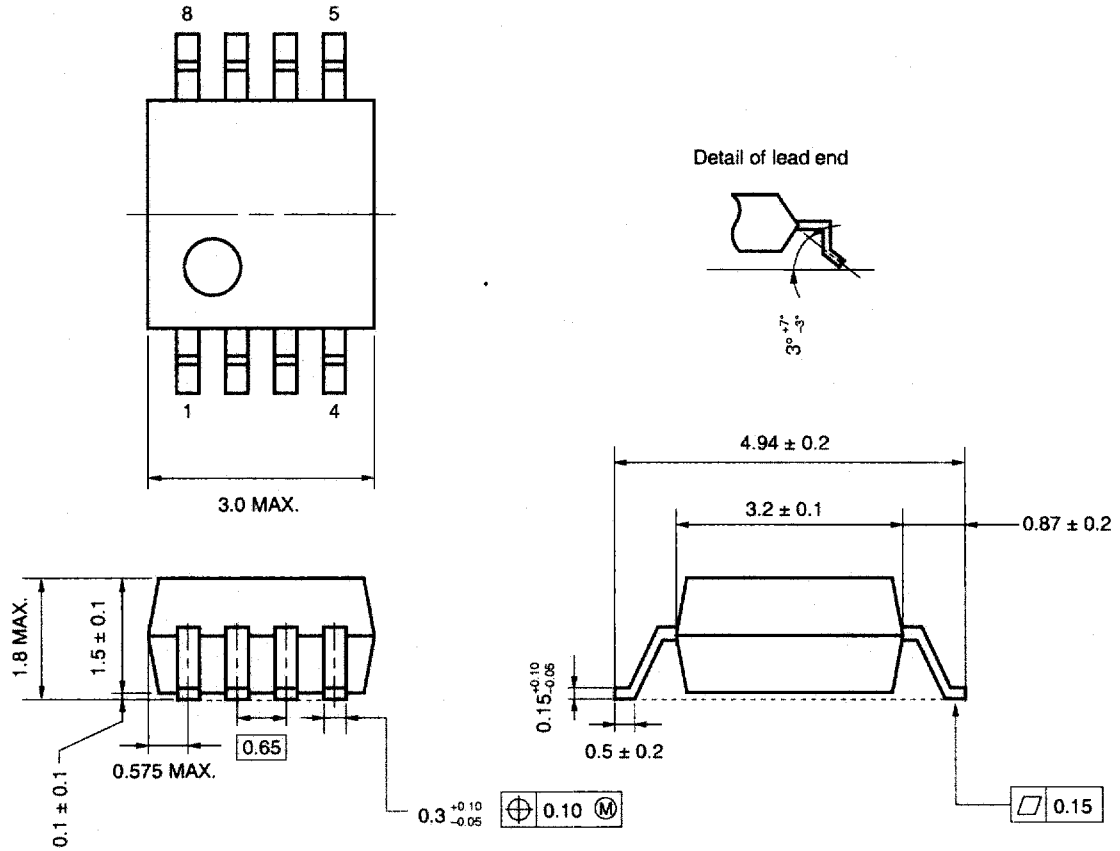

RECOMMENDED SOLDERING CONDITIONS

This product should be soldered in the following recommended conditions. Other soldering methods and conditions than the recommended conditions are to be consulted with our sales representatives.

Soldering process	Soldering Conditions	Symbol
Infrared Ray Reflow	Peak package's surface temperature: 235°C or below Reflow time: 30 seconds or less (at 210°C) Number of reflow process: 3, Exposure limit ^{Note} : None	IR35-00-3
VPS	Peak package's surface temperature: 215°C or below Reflow time: 40 seconds or less (at 200°C) Number of reflow process: 3, Exposure limit ^{Note} : None	VP15-00-3
Wave Soldering	Solder temperature: 260°C or below Flow time: 10 seconds or less Number of flow process: 1, Exposure limit ^{Note} : None	WS60-00-1
Partial Heating Method	Terminal temperature: 300°C Flow time: 3 seconds or less (per one pin), Exposure limit ^{Note} : None	

Note Exposure limit before soldering after dry-pack package is opened.
Storage conditions: 25°C and relative humidity at 65% or less.

Caution Do not apply more than a single process at once, except for "partial heating method".

[MEMO]

Caution

**The Great Care must be taken in dealing with the devices in this guide.
The reason is that the material of the devices is GaAs (Gallium Arsenide), which is
designated as harmful substance according to the law concerned.
Keep the law concerned and so on, especially in case of removal.**

The application circuits and their parameters are for reference only and are not intended for use in actual design-ins.

No part of this document may be copied or reproduced in any form or by any means without the prior written consent of NEC Corporation. NEC Corporation assumes no responsibility for any errors which may appear in this document.

NEC Corporation does not assume any liability for infringement of patents, copyrights or other intellectual property rights of third parties by or arising from use of a device described herein or any other liability arising from use of such device. No license, either express, implied or otherwise, is granted under any patents, copyrights or other intellectual property rights of NEC Corporation or others.

While NEC Corporation has been making continuous effort to enhance the reliability of its semiconductor devices, the possibility of defects cannot be eliminated entirely. To minimize risks of damage or injury to persons or property arising from a defect in an NEC semiconductor device, customers must incorporate sufficient safety measures in its design, such as redundancy, fire-containment, and anti-failure features.

NEC devices are classified into the following three quality grades:

"Standard", "Special", and "Specific". The Specific quality grade applies only to devices developed based on a customer designated "quality assurance program" for a specific application. The recommended applications of a device depend on its quality grade, as indicated below. Customers must check the quality grade of each device before using it in a particular application.

Standard: Computers, office equipment, communications equipment, test and measurement equipment, audio and visual equipment, home electronic appliances, machine tools, personal electronic equipment and industrial robots

Special: Transportation equipment (automobiles, trains, ships, etc.), traffic control systems, anti-disaster systems, anti-crime systems, safety equipment and medical equipment (not specifically designed for life support)

Specific: Aircrafts, aerospace equipment, submersible repeaters, nuclear reactor control systems, life support systems or medical equipment for life support, etc.

The quality grade of NEC devices is "Standard" unless otherwise specified in NEC's Data Sheets or Data Books. If customers intend to use NEC devices for applications other than those specified for Standard quality grade, they should contact an NEC sales representative in advance.

Anti-radioactive design is not implemented in this product.