

HD74LV32

Quad. 2-input OR Gates

Description

The HD74LV32 has four 2-input OR gates in a 14 pin package. Low voltage and high speed operation is suitable at the battery drive product (note type personal computer) and low power consumption extends the life of a battery for long time operation.

Features

- $V_{CC} = 2.0\text{ V to }5.5\text{ V}$
- All inputs $V_{IH} (\text{Max.}) = 5.5\text{ V} (@V_{CC} = 0\text{ V to }5.5\text{ V})$
- Typical V_{OL} ground bounce $< 0.8\text{ V} (@V_{CC} = 3.3\text{ V}, T_a = 25^\circ\text{C})$
- Typical V_{OH} undershoot $> 2.0\text{ V} (@V_{CC} = 3.3\text{ V}, T_a = 25^\circ\text{C})$
- Output current $\pm 6\text{ mA} (@V_{CC} = 3.0\text{ V to }3.6\text{ V})$
 $\pm 12\text{ mA} (@V_{CC} = 4.5\text{ V to }5.5\text{ V})$

Function Table

Inputs		Output Y
A	B	
L	L	L
H	L	H
L	H	H
H	H	H

H: High level

L: Low level

Pin Arrangement

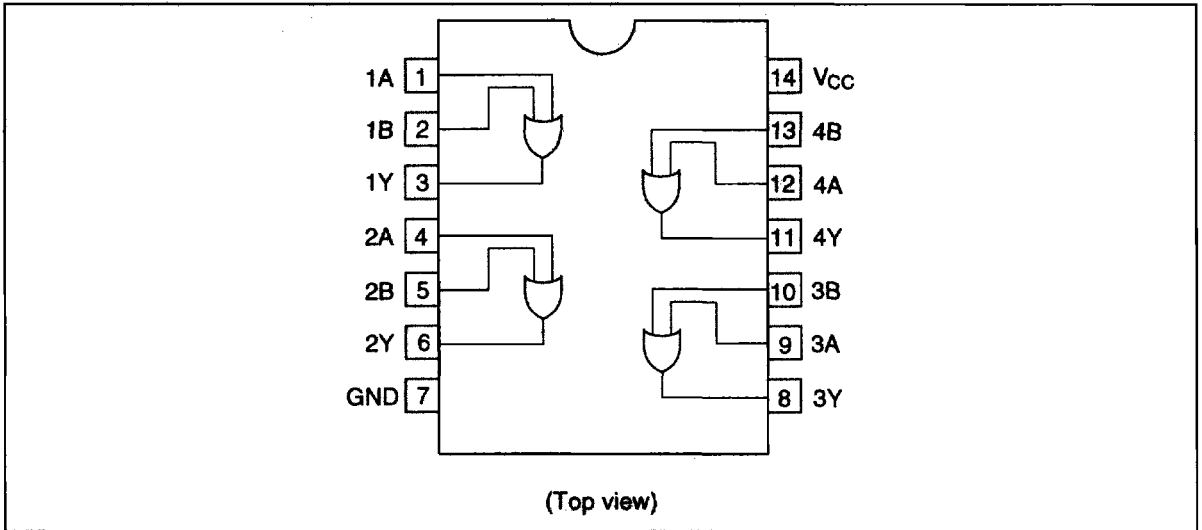

Absolute Maximum Ratings

Item	Symbol	Ratings	Unit	Conditions
Supply voltage	V_{CC}	-0.5 to 7.0	V	
Input diode current	I_{IK}	-20	mA	$V_I = -0.5$ V
Input voltage	V_I	-0.5 to 7.0	V	
Output diode current	I_{OK}	-50	mA	$V_O = -0.5$ V
		50	mA	$V_O = V_{CC} + 0.5$ V
Output voltage	V_O	-0.5 to $V_{CC} + 0.5$	V	
Output current	I_O	± 25	mA	
V_{CC} , GND current / pin	I_{CC} or I_{GND}	50	mA	
Storage temperature	T_{stg}	-65 to +150	$^{\circ}$ C	

Note: The absolute maximum ratings are values which must not individually be exceeded, and furthermore, no two of which may be realized at the same time.

HD74LV32

Recommended Operating Conditions

Item	Symbol	Ratings	Unit	Conditions
Supply voltage	V_{CC}	2.0 to 5.5	V	
Input / output voltage	V_I	0 to 5.5	V	A, B
	V_O	0 to V_{CC}	V	Y
Operating temperature	T_a	-40 to 85	°C	
Output current	I_{OH}	-6	mA	$V_{CC} = 3.0\text{ V to }3.6\text{ V}$
		-12 *2	mA	$V_{CC} = 4.5\text{ V to }5.5\text{ V}$
	I_{OL}	6	mA	$V_{CC} = 3.0\text{ V to }3.6\text{ V}$
		12 *2	mA	$V_{CC} = 4.5\text{ V to }5.5\text{ V}$
Input rise / fall time *1	t_r, t_f	50	ns/V	$V_{CC} = 5.5\text{ V}$
		100	ns/V	$V_{CC} = 3.6\text{ V}$

Notes: 1. This item guarantees maximum limit when one input switches.

Waveform : Refer to test circuit of switching characteristics.

2. duty cycle $\leq 50\%$

Electrical Characteristics

Item	Symbol	$V_{CC}(V)$	$T_a = -40\text{ to }85^\circ\text{C}$		Unit	Test Conditions
			Min	Max		
Input voltage	V_{IH}	2.7 to 3.6	2.0	—	V	
		4.5 to 5.5	$V_{CC} \times 0.7$	—	V	
	V_{IL}	2.7 to 3.6	—	0.8	V	
		4.5 to 5.5	—	$V_{CC} \times 0.3$	V	
Output voltage	V_{OH}	2.7 to 5.5	$V_{CC} - 0.2$	—	V	$I_{OH} = -100\ \mu\text{A}$
		3.0	2.4	—	V	$I_{OH} = -6\ \text{mA}$
		4.5	3.6	—	V	$I_{OH} = -12\ \text{mA}$
	V_{OL}	2.7 to 5.5	—	0.2	V	$I_{OL} = 100\ \mu\text{A}$
		3.0	—	0.4	V	$I_{OL} = 6\ \text{mA}$
		4.5	—	0.5	V	$I_{OL} = 12\ \text{mA}$
Input current	I_{IN}	0 to 5.5	—	± 1.0	μA	$V_{IN} = 5.5\text{ V or GND}$
Quiescent supply current	I_{CC}	5.5	—	20	μA	$V_{IN} = V_{CC}\text{ or GND}$
	ΔI_{CC}	3.0 to 3.6	—	500	μA	$V_{IN} = \text{one input at } (V_{CC} - 0.6)\text{V, other inputs at } V_{CC}\text{ or GND}$

Switching Characteristics

Item	Symbol	V _{CC} (V)	Ta = 25°C			Ta = -40 to 85°C			Unit	From (Input)	To (Output)	
			Min	Typ	Max	Min	Typ	Max				
Propagation delay time	t _{PLH}	2.7	—	10.0	16.0	1.0	—	17.5	ns	A or B	Y	
			3.3±0.3	—	8.0	13.5	1.0	—				15.0
			5.0±0.5	—	6.0	11.0	1.0	—				12.0
Input capacitance	C _{IN}	3.3±0.3	—	—	—	—	2.5	—	pF			

Test Circuit

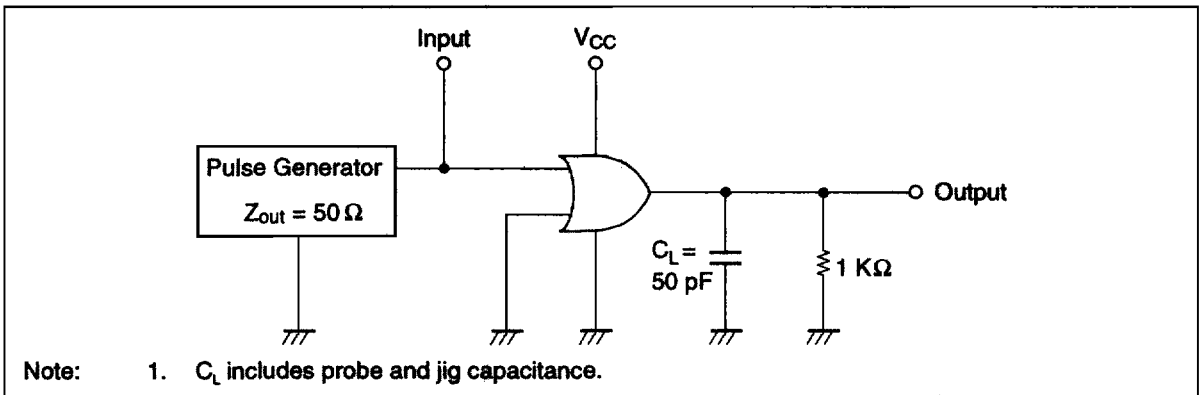

HD74LV32

Waveforms

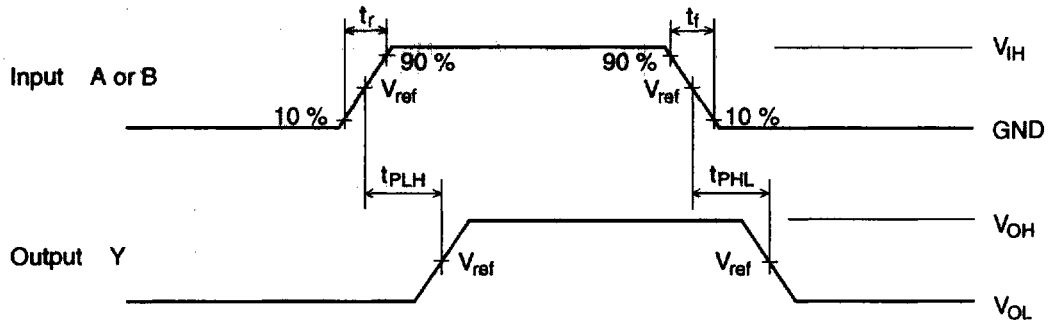

Symbol	$V_{CC} = 2.7\text{ V},$ $3.3 \pm 0.3\text{ V}$	$V_{CC} = 5.0 \pm 0.5\text{ V}$
V_{IH}	2.7 V	V_{CC}
V_{ref}	1.5 V	$50\%V_{CC}$

- Notes:
1. $t_r = 2.5\text{ ns}, t_f = 2.5\text{ ns}$
 2. Input waveform : PRR = 10 MHz, duty cycle 50%