

10-Port Layer-2 Gigabit Ethernet Switch with 8 Fully Integrated Copper PHYs

Vitesse's next-generation switch device delivers the industry's lowest power GbE switching solution

Highlights

- Supports IEEE 802.3az and green energy efficiency modes with ActiPHY™ and PerfectReach™
- Lowest BOM solution requires only one IC
- Up to two SGMII ports with 100 Mbps and 1 Gbps fiber support

Applications

- Ethernet switches
- Edge and Access platforms
- Customer-premises equipment (CPE) and network termination equipment (NTE)

The VSC7420 is the industry's first fully integrated 10-port Gigabit Ethernet switch with eight copper PHYs in a single package.

The VSC7420 leverages Vitesse's new 65 nm SimpliPHY™ technology, resulting in the one of the most cost-effective and lowest power consumption devices in the industry. The single-chip solution combines the most advanced Ethernet energy efficiency features for bringing green technology solutions to market.

The VSC7420 provides a rich set of unmanaged Ethernet switching features such as Layer-2 forwarding with basic VLAN and QoS processing, enabling the delivery of differentiated services. The VSC7420 contains an 8051 CPU for light management of the switch.

A comprehensive application software package is provided for LED control, loop indication, device overheat protection, and other enhanced functions.

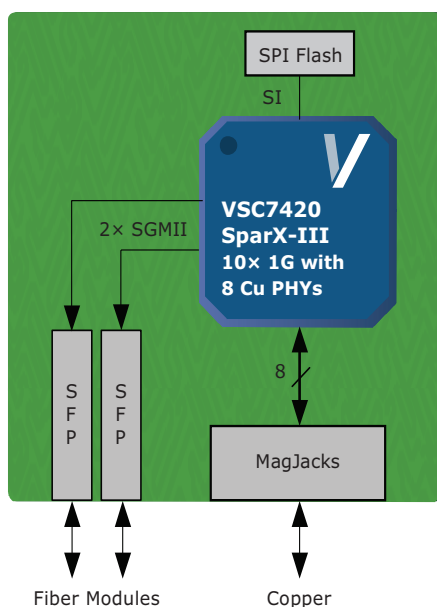

VSC7420 in a 10-port 1-GbE switch application

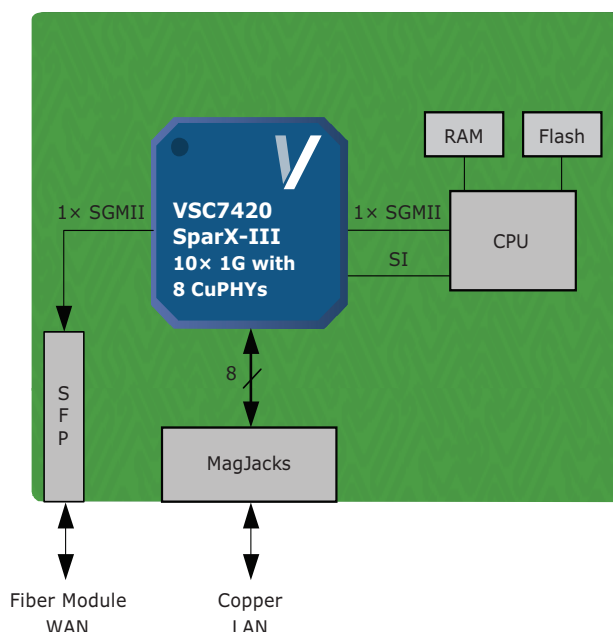

VSC7420 in a 9-port 1-GbE router application

Best-in-Class Power Consumption

- Lowest power 10-port Gigabit Ethernet switch available in the market
- Green energy efficiency modes including ActiPHY™, PerfectReach™, and Draft IEEE 802.3az
- Single IC reduces overall power requirements
- Optimal power consumption for all link speeds

Features

- Eight integrated IEEE 802.3ab-compliant 10/100/1000BASE-T Ethernet copper transceivers with VeriPHY™ cable diagnostics
- Two SGMII MAC interfaces
- Integrated 250 MHz 8051 CPU with 64 KB internal storage
- Serial interface for external CPU register access
- Device overheat protection
- Hardware loop detection
- Integrated fan controller
- 8 K MAC addresses and 4 K VLAN support
- Supports IEEE 1149.1 JTAG boundary scan, IEEE 1149.6 AC-JTAG, 1 Gbps SGMII, and 100BASE-FX and 1000BASE-X

Layer 2 Switching

- 10-port Gigabit Ethernet switch with nonblocking wire-speed performance
- Link aggregation (IEEE 802.3ad) with programmable traffic distribution based on Layer 2 through Layer 4 information
- Wire-speed hardware-based learning and CPU-based learning configurable per port
- Independent and shared VLAN learning
- Jumbo frame support up to 12.2 kilobytes with per-port programmable MTU
- Q-in-Q tagging support
- 4 megabits of integrated shared packet memory

QoS

- Eight QoS queues per port with strict or deficit-weighted round robin scheduling
- QoS classification based on IEEE 802.1p and IPv4/IPv6 DSCP
- Data rate shaper and policer per-queue, per-port for both ingress and egress directions
- Full-duplex flow control (IEEE 802.3x) and half-duplex backpressure, symmetric and asymmetric
- Multicast and broadcast storm control with flooding control

Key Specifications

- 1 V core power supply
- 2.5 V I/O power supplies
- 24 mm × 24 mm thin QFP package

Related Vitesse Products

Visit www.vitesse.com for information about these related Vitesse products:

- Ethernet switches
- 1G copper PHYs

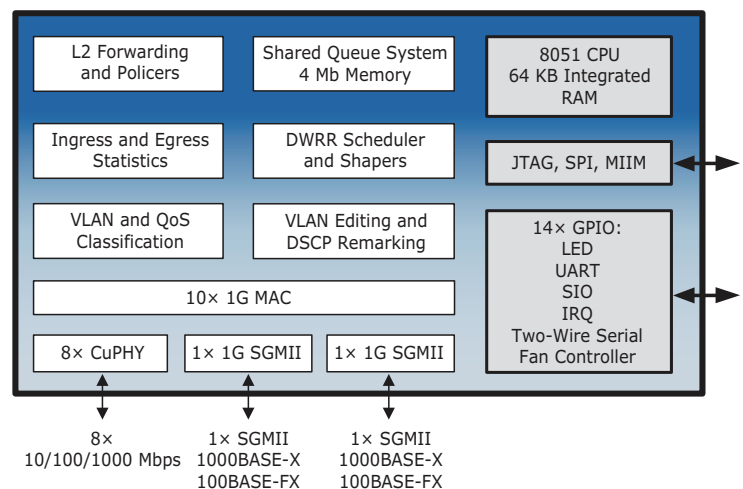

Vitesse Semiconductor Corporation

741 Calle Plano • Camarillo, CA 93012 USA • Tel: +1.800.VITESSE • +1.805.388.3700 • Fax: +1.805.987.5896 • www.vitesse.com

© 2010 by Vitesse Semiconductor Corporation. VPPD-02597 Revision 1.0. Vitesse Semiconductor Corporation ("Vitesse") retains the right to make changes to its products or specifications. As such, all information in this document, including descriptions of features, functions, performance, technical specifications and availability, is subject to change without notice at any time, and Vitesse assumes no responsibility for use of any information herein. Nothing contained herein conveys to the purchaser of microelectronic devices any license under the patent or any other intellectual property rights of any manufacturer. Vitesse®, and numerous other trademarks, are trademarks of Vitesse in the United States and/or other jurisdictions. Other trademarks used herein that are not the property of Vitesse are the property of their respective owners. While Vitesse products support IEC 60825, use of Vitesse products does not ensure compliance to IEC 60825. Buyers are responsible for ensuring compliance to IEC 60825. Buyers must fully indemnify Vitesse for any damages resulting from non-compliance to IEC 60825.