

SL1452

WIDEBAND LINEAR FM DETECTOR FOR SATELLITE TV

With a minimum of external components, the SL1452 forms a complete wideband FM detector suitable for use in satellite TV. The video output and bandwidth may be optimised by adjustment of the working Q of the quadrature coil.

FEATURES

- High Operating Frequency Simplifies Image Filtering
- Negligible Differential Gain and Phase Errors
- Video Bandwidth Suitable for High Definition TV
- High Sensitivity and Wide Dynamic Range
- Wide Operating Frequency Range: 300 to 1000 MHz
- Electrostatic Protection*

* Normal ESD handling precautions should be observed

ORDERING INFORMATION

SL1452 NA DP (8-lead plastic DIL package)

SL1452 NA MP (8-lead miniature plastic DIL package)

ABSOLUTE MAXIMUM RATINGS

Operating temperature range	-10°C to +80°C
Supply voltage, pin 6	7V
Input voltage, pin 7 or 8	2.5V p-p
Storage temperature	-55°C to +150°C
Junction temperature	+175°C

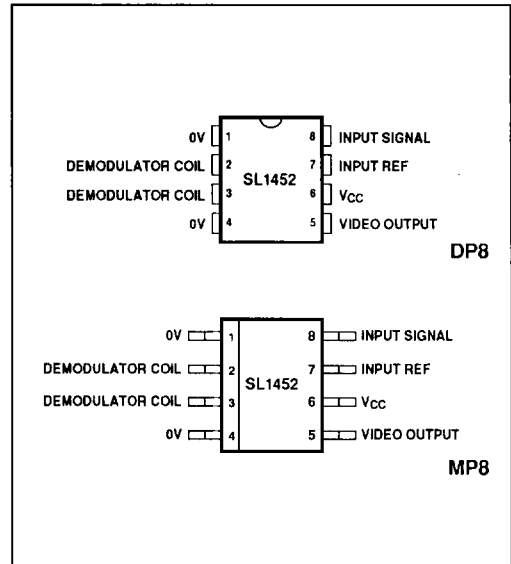

Fig. 1 Pin connections - top view (not to scale)

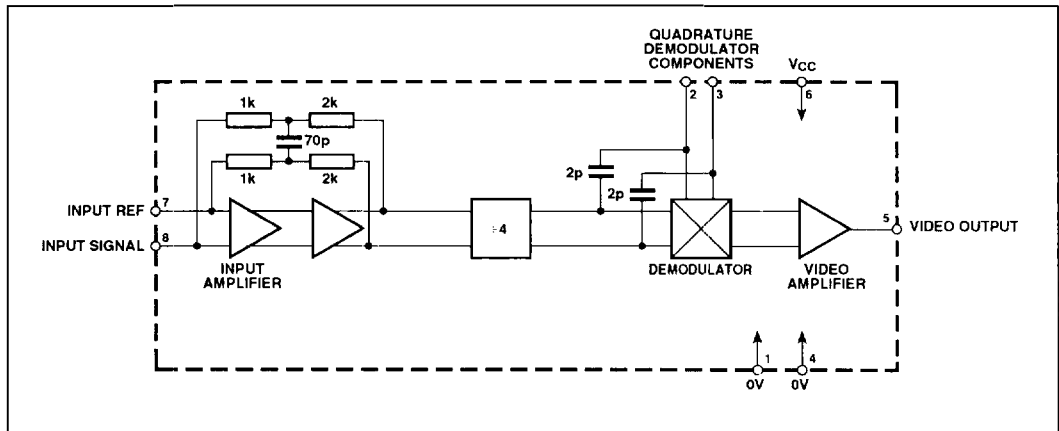

Fig. 2 Block diagram

ELECTRICAL CHARACTERISTICS

These characteristics are guaranteed over the following conditions (unless otherwise stated):

$$T_{AMB} = +25^{\circ}\text{C}, V_{CC} = +4.5\text{V to } +5.5\text{V}, Q = 6, f = 612\text{MHz}$$

Characteristic	Pin	Value			Units	Conditions
		Min.	Typ.	Max.		
Supply current, I_{CC}	6		40	50	mA	$V_{CC} = 5\text{V}$ $\Delta f = 13.5\text{MHz p-p}$ Product of input modulation: $f = 4.4\text{MHz}$, $\Delta f = 13.5\text{MHz p-p}$ and $f = 6\text{MHz}$, $\Delta f = 2\text{MHz p-p}$ (PAL colour and sound subcarriers). $\Delta f = 13.5\text{MHz p-p}$. Demodulated staircase referred to input staircase before modulation. Demodulated colour bar waveform referred to waveform before modulation. Ratio of output with $\Delta f = 13.5\text{MHz p-p}$ at 1MHz to output rms noise in 10MHz bandwidth with $\Delta f = 0$.
Video output voltage	5		0.7		V p-p	
Video bandwidth	5		14		MHz	
Minimum operating frequency	8		300		MHz	
Maximum operating frequency	8		1000		MHz	
Input voltage	8	10		300	mVrms	
Intermodulation	5		-60		dB	
Differential gain	5		$< \pm 1$		%	
Differential phase	5		$< \pm 1$		deg	
Signal-to-noise ratio	5	70			dB	

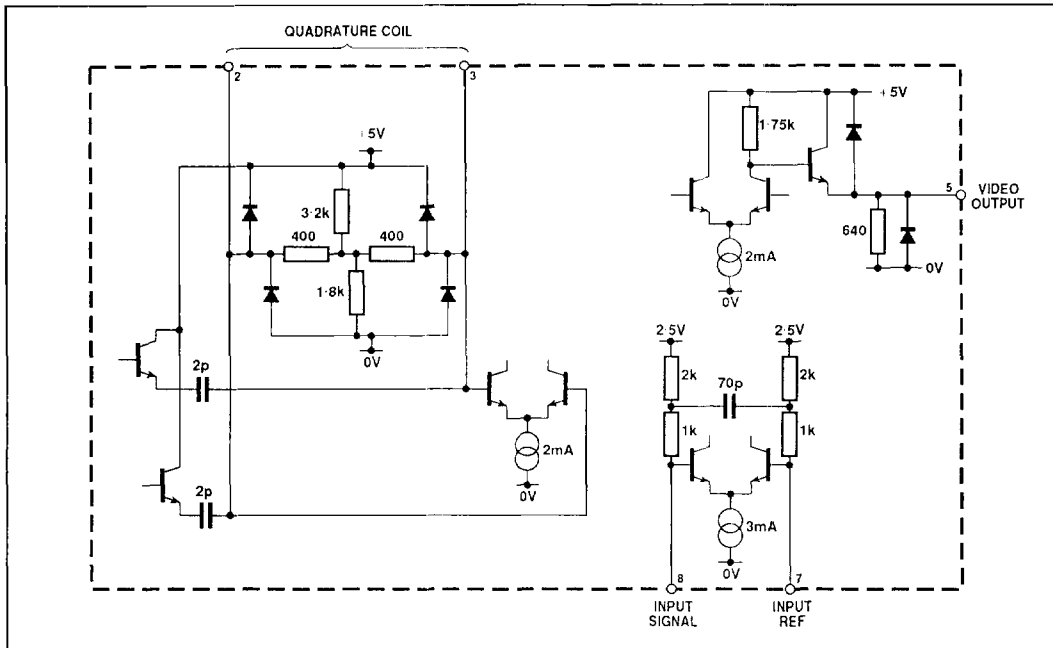

Fig. 3 Input/output interface circuits

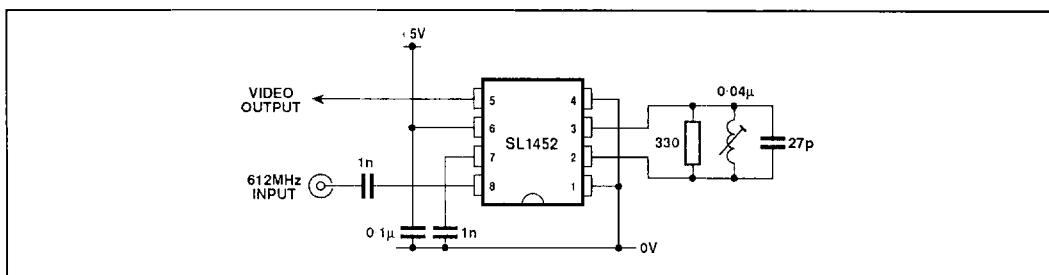

Fig. 4 Typical application

SL1452 QUADRATURE DEMODULATOR

The SL1452 FM demodulator has a simple application with very low external component count. This is demonstrated by the applications circuit diagram Fig. 4, but as with most integrated circuits, particularly those working at high frequencies, some attention to good RF layout techniques and correct component selection will ensure optimum results.

A good layout can usually be ensured by the simple precaution of keeping all components close to the SL1452, maintaining short lead lengths and ensuring a good low impedance ground plane. Double sided board layout enables these objectives to be easily met, but is not essential for satisfactory operation. All coupling and decoupling capacitors should be chosen for low impedance characteristics at high frequencies, multilayer ceramic types usually providing small size and adequate high frequency performance. For the quadrature coil tuning capacitor a fairly stable component should be selected to prevent excessive drift. The power supply decoupling capacitor from pin 6 to ground should be 0.1µF minimum but the input coupling and decoupling values can be smaller, about 330pF being adequate.

The only remaining components to be selected are those forming the quadrature circuit on pins 2 and 3 and some care in the determination of values for these is required if maximum performance is to be obtained.

First determine the quadrature circuit operating frequency, which is a quarter of the input frequency on pin 8 due to the two internal ± 2 stages (see Fig.2).

Choose suitable values for L and C to resonate at the correct frequency using:

$$f = \frac{1}{2\pi\sqrt{LC}}$$

The value of C should be greater than 15pF to prevent stray capacitance effects introducing errors and distortion of the demodulation curve, but the use of very large capacitances with small inductance values will lower the impedance of the tuned circuit at the required Q value, reducing the drive level to the demodulator and thereby restricting the video output available. In general, for operation in the 400MHz to 600MHz range, an inductance value between 40nH and 60nH is recommended.

Once suitable L and C values have been determined, the working Q for the quadrature circuit should be set, the Q value determining the video output level and bandwidth. Video output is proportional to Q whereas video bandwidth is inversely proportional. The effect of Q variations on video bandwidth and amplitude can be determined from Table 1 and the graphs in Fig. 5.

A value for total damping resistor value to obtain the required Q can be calculated from:

$$R = Q2\pi L$$

The internal 800Ω resistance between pins 2 and 3 must be allowed for when calculating R.

Example

Design a quadrature circuit to demodulate a carrier on pin 8 with centre frequency 480 MHz and video bandwidth of 10MHz.

For $L = 40\text{nH}$, $f_{\text{QUAD}} = 120\text{MHz}$,
 $C = 43.98\text{pF}$ (nearest preferred value 47pF)
 From Table 1, Q required is approximately 6,
 therefore total R required is:

$$\begin{aligned} R &= Q2\pi L \\ &= 6 \times 2 \times \pi \times \frac{480 \times 10^6 \times 0.04 \times 10^{-6}}{4} \\ &= 181 \text{ ohms} \end{aligned}$$

Allowing for the internal 800Ω resistance between pins 2 and 3 (see Fig.3), the external resistance required is 234Ω ; choose 270Ω.

It should be remembered that the internal 800Ω resistance is subject to production tolerances and if fairly close control of video bandwidth is required, the L and C ratio may require some adjustment to ensure that the external R is sufficiently low to swamp the effect of internal resistance changes. The value of 270Ω obtained in the example is low enough to allow adequate control.

In order to overcome the effects of component tolerances, it will usually be necessary to make either the L or C a variable component, the value being adjusted to obtain best linearity.

Q	Bandwidth
10	7.5MHz
6	14MHz
4	23MHz

Table 1

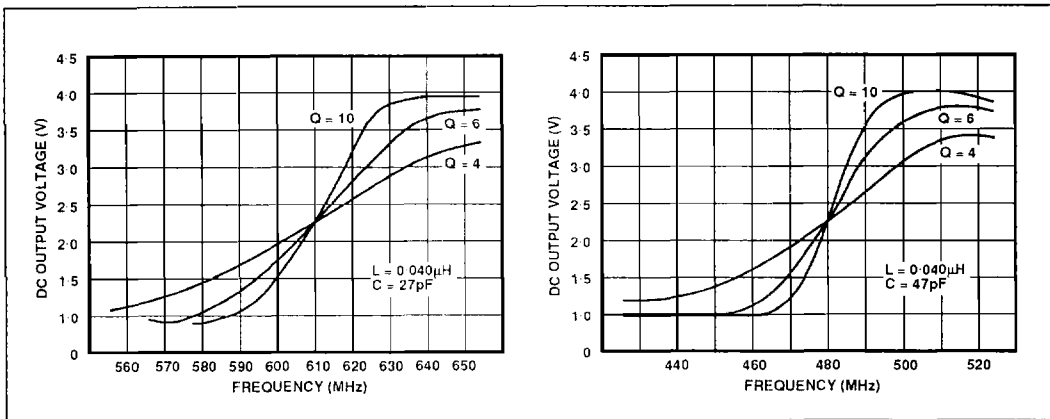

Fig. 5 Output voltage v. input frequency