

GIM500R - 2-dimensional

 2-dimensional, measuring range up to $\pm 90^\circ$

CANopen® / SAE J1939 / Analog

Overview

- Size 52 mm
- MEMS capacitive measuring principle
- E1 compliant design
- Interface CANopen®, SAE J1939, Analog
- Connection M12 and cable
- Protection up to IP 69K
- Applicable up to PLd (ISO 13849)

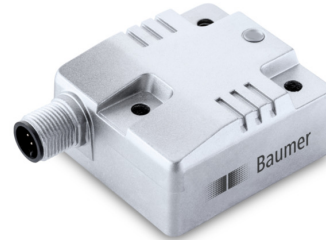

Technical data

Technical data - electrical ratings

| | |
|-----------------------------|--|
| Voltage supply | 8...36 VDC |
| Reverse polarity protection | Yes |
| Consumption w/o load | ≤ 40 mA (24 VDC) |
| Initializing time | ≤ 0.5 s after power on |
| Interface | CANopen® SAE J1939 Analog (4...20 mA / 0.5...4.5 V / 0...5 V / 0...10 V) |
| Load resistor | ≥ 1 k Ω / voltage output ≤ 800 Ω / current output |
| Measuring range | $\pm 10^\circ / \pm 30^\circ / \pm 45^\circ / \pm 60^\circ / \pm 90^\circ$ |
| Resolution | 0.01 ° CANopen® 0.01 ° SAE J1939 12 bit Analog |
| Accuracy (+25 °C) | Typ. $\pm 0.1^\circ$ |
| Temperature coefficient | 0.008 °/K |
| Cross-axis-sensitivity typ. | 0.3 % |
| Repeatability | $\pm 0.1^\circ$ (+25 °C) |
| Sensing rate | 1600 Hz |
| Limit frequency | 0.1...25 Hz, 2. order / low-pass filter (Default: 5 Hz) |
| Interference immunity | EN 61000-6-2 ECE Reg. No. 10R04 ISO 7637-2 ISO 11452-2 / ISO 11452-5 |
| Emitted interference | EN 61000-6-4 ECE Reg. No. 10R04 ISO 7637-2 / EN 55025 |

Technical data - electrical ratings

| | |
|-------------------------------|--|
| MTTF _d (ISO 13849) | High (> 100 years) Use in safety functions exclusively based on Application Note and MTTF _d reliability prediction (request separately). |
| Programmable parameters | Preset and offset Filter |
| Diagnostic function | Parameter error |
| Status indicator | DUO-LED integrated in housing |
| Approval | UL approval / E63076 |

Technical data - mechanical design

| | |
|-----------------------|--|
| Dimensions W x H x L | 48 x 24 x 52 mm |
| Protection EN 60529 | IP 66 IP 67 IP 68 IP 69K |
| Material | Housing: aluminium, coated |
| Corrosion protection | IEC 60068-2-52 Salt mist for ambient conditions CX (C5-M) according to ISO 12944-2 |
| Operating temperature | -40...+85 °C (see general information) |
| Resistance | EN 60068-2-6 Vibration 20 g, 60-2000 Hz EN 60068-2-27 Shock 200 g, 6 ms |
| Weight approx. | 95 g |
| Connection | Flange connector M12, 8-pin Flange connector M12, 5-pin Cable 1 m |

Optional

- With integrated terminating resistor
- Connection with DEUTSCH connector
- Output signal with out-of-range diagnostics

GIM500R - 2-dimensional

2-dimensional, measuring range up to $\pm 90^\circ$

CANopen® / SAE J1939 / Analog

General information

Self-heating correlated to installation and ambient conditions as well as to electronics and supply voltage must be considered for precise thermal dimensioning. The inclination sensor is supposed to self-heat to approximately 5 K when attached to a varnished ground metal. Operating the inclination sensor close to the maximum limits requires measuring the currently prevailing temperature at the housing. Vibration with frequency in the range of 1600 Hz acting on the sensor leads to reduced measuring accuracy. Teach/preset of zero position outside a range of $\pm 5^\circ$ around factory settings of zero position (inclination 0°) can lead to reduced measuring accuracy (valid for analog interfaces with measuring range up to $\pm 30^\circ$).

Installation position

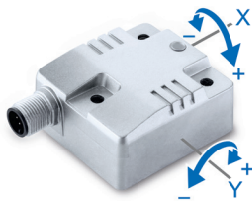

Horizontal installation

When installing the 2-dimensional inclination sensor with the housing in horizontal position, make sure the base plate is aligned parallel to the horizontal line.

The sensor can be inclined both towards the X and the Y axis. There is one measured value supplied for each axis. Sensor default is 2-dimensional measuring within the selected range, e.g. $\pm 30^\circ$. Zero-crossing is exactly in the horizontal line.

$y = 0^\circ$



$y = -30^\circ$



$x = 0^\circ$



$x = +30^\circ$

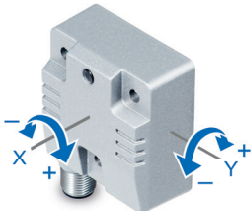

Vertical installation

When installing the 2-dimensional inclination sensor with the housing in vertical position, make sure the base plate is aligned parallel to the vertical line. The sensor can be inclined both towards the X and the Y axis. There is one measured value supplied for each axis.

Sensor default is 2-dimensional measuring within the selected range, e.g. $\pm 30^\circ$. Zero-crossing is exactly in the vertical line.

$y = 0^\circ$



$y = -30^\circ$



$x = 0^\circ$



$x = +30^\circ$



GIM500R - 2-dimensional

2-dimensional, measuring range up to $\pm 90^\circ$

CANopen® / SAE J1939 / Analog

Terminal assignment

Analog – M12 flange connector, 8-pin

| Pin | Assignment | Description |
|-----|---------------------|--------------------------------------|
| 1 | +Vs | Voltage supply |
| 2 | GND | Ground connection relating to +Vs |
| 3 | OUT_X | Output |
| 4 | OUT_Y | Output |
| 5 | Teach ¹⁾ | Teach-Input |
| 6 | d.u. | Do not use |
| 7 | d.u. | Do not use |
| 8 | A_GND | Ground connection relating to analog |

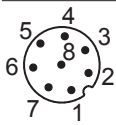

M12 flange connector (male),
A-coded

Analog – cable

| Core color | Assignment | Description |
|------------|---------------------|--------------------------------------|
| White | +Vs | Voltage supply |
| Brown | GND | Ground connection relating to +Vs |
| Green | OUT_X | Output |
| Yellow | OUT_Y | Output |
| Grey | Teach ¹⁾ | Teach-Input |
| Pink | d.u. | Do not use |
| Blue | d.u. | Do not use |
| Red | A_GND | Ground connection relating to analog |

¹⁾ Function zero setting
See description zero setting

CANopen® / SAE J1939 – M12 flange connector, 5-pin

| Pin | Assignment | Description |
|-----|------------|-----------------------------------|
| 1 | CAN_GND | Ground connection relating to CAN |
| 2 | +Vs | Voltage supply |
| 3 | GND | Ground connection relating to +Vs |
| 4 | CAN_H | CAN Bus Signal (dominant High) |
| 5 | CAN_L | CAN Bus Signal (dominant Low) |

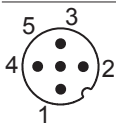

M12 flange connector (male),
A-coded

Terminal assignment

CANopen® / SAE J1939 – 2xM12 flange connector, 5-pin

| Pin | Assignment | Description |
|-----|------------|-----------------------------------|
| 1 | CAN_GND | Ground connection relating to CAN |
| 2 | +Vs | Voltage supply |
| 3 | GND | Ground connection relating to +Vs |
| 4 | CAN_H | CAN Bus Signal (dominant High) |
| 5 | CAN_L | CAN Bus Signal (dominant Low) |

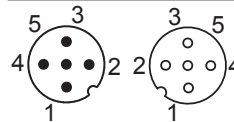

M12 flange connector (male / female),
A-coded

Terminals of the same significance are internally connected and identical in their functions. Max. load on the internal terminal connections Vs-Vs and GND-GND is 1 A each.

CANopen® – Cable

| Core color | Assignment | Description |
|------------|------------|-----------------------------------|
| White | +Vs | Voltage supply |
| Brown | GND | Ground connection relating to +Vs |
| Green | d.u. | – |
| Yellow | d.u. | – |
| Grey | d.u. | – |
| Pink | CAN_H | CAN Bus Signal (dominant High) |
| Blue | CAN_L | CAN Bus Signal (dominant Low) |
| Red | CAN_GND | Ground connection relating to CAN |

CANopen® features

| | |
|----------------|--|
| Bus protocol | CANopen® |
| Device profile | CANopen® - CiA DSP 301 V4.2 Inclinometer profile DS 410 V1.3 LSS service profile DS 305 V2.2 |
| Default | Resolution 0.1° Baud rate 50 kbit/s Node ID 1 |

GIM500R - 2-dimensional

2-dimensional, measuring range up to $\pm 90^\circ$

CANopen® / SAE J1939 / Analog

Output signals

Analog output

Measuring range $\pm 30^\circ$ / Mounting position horizontal

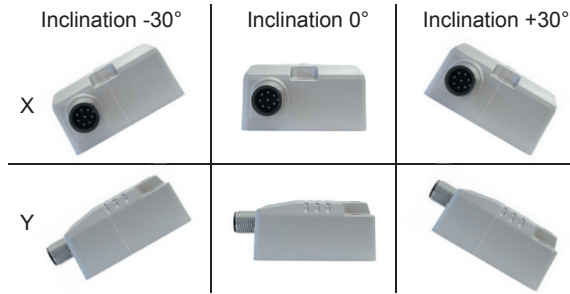
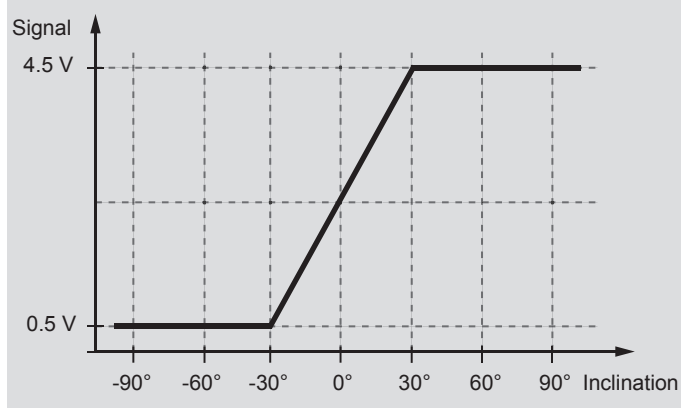

Output signals

Measuring range $\pm 90^\circ$ / Mounting position horizontal

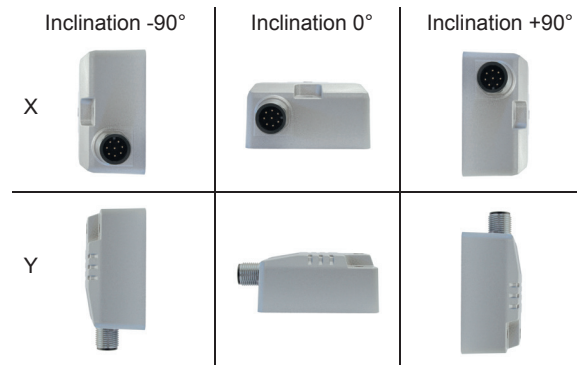
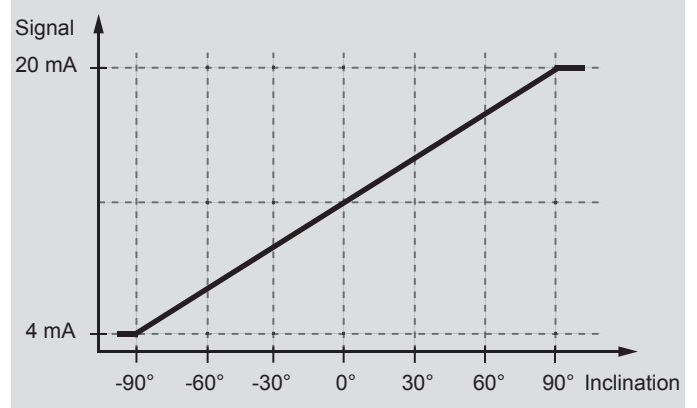

Measuring range $\pm 60^\circ$ / Mounting position vertical

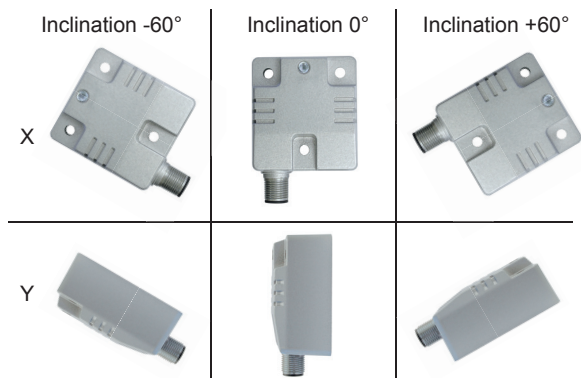
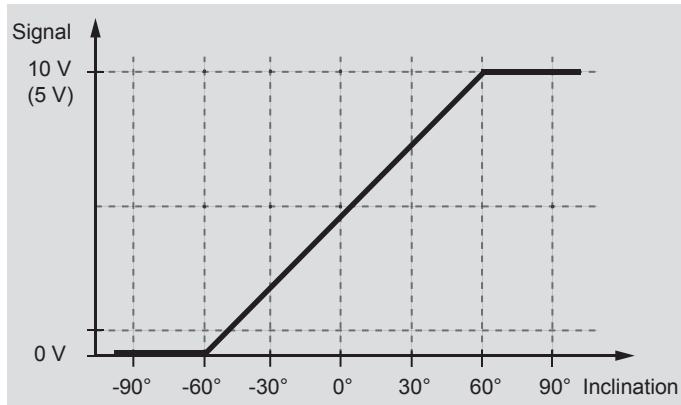

GIM500R - 2-dimensional

2-dimensional, measuring range up to $\pm 90^\circ$

CANopen® / SAE J1939 / Analog

Output signals

Analog output with out-of-range diagnostic (Option: /4822)

Measuring range $\pm 30^\circ$ / Mounting position horizontal

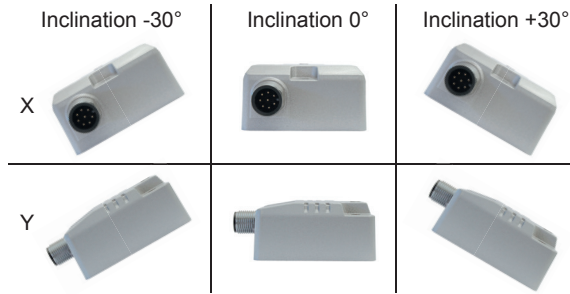
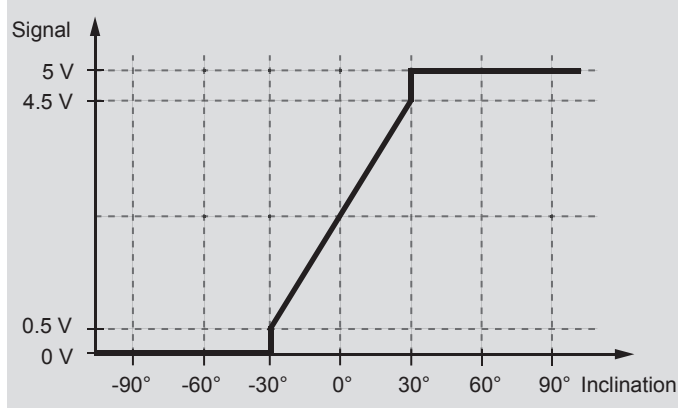

Output signals

Measuring range $\pm 90^\circ$ / Mounting position horizontal

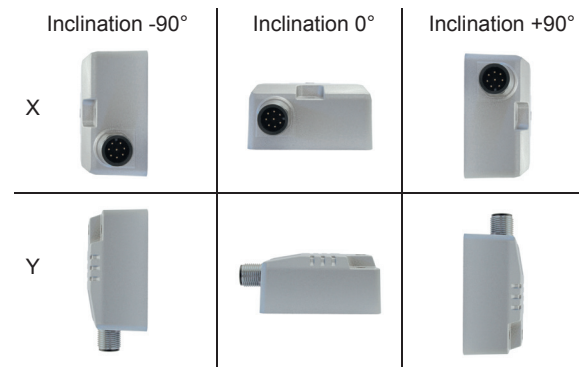
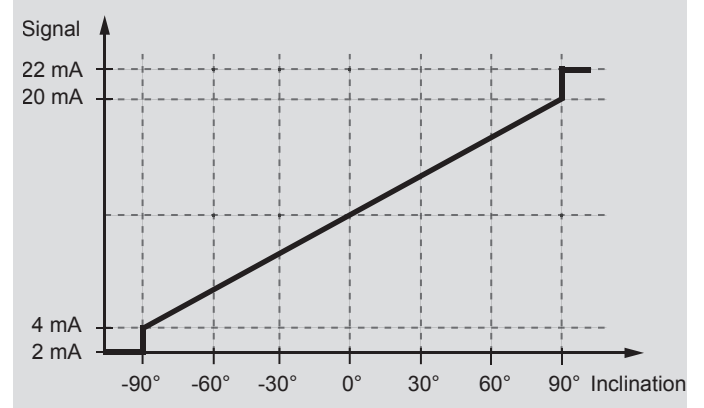

Measuring range $\pm 60^\circ$ / Mounting position vertical

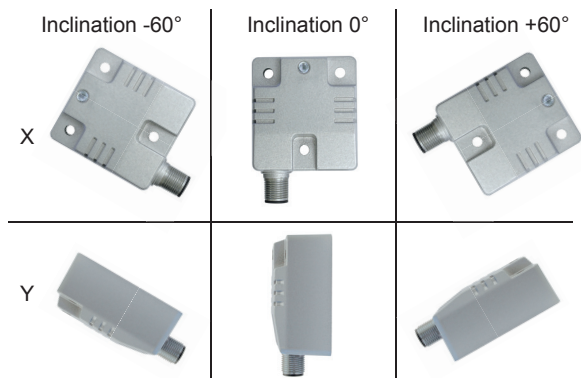
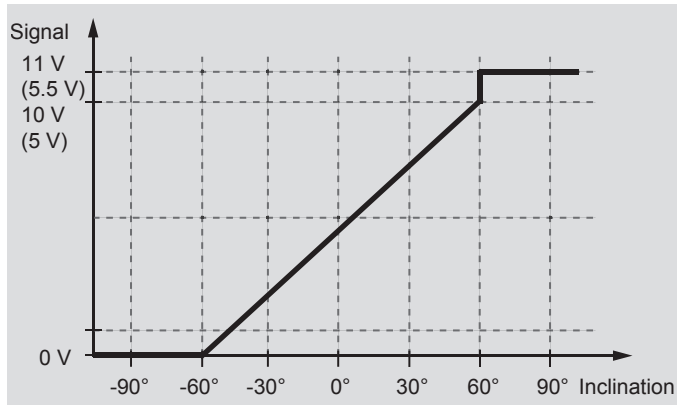

Zero setting

Set Teach input for >250 ms on HIGH level ($\geq 0.7 \cdot +Vs$) conforms inclination 0° . Zero setting affects both axes (X/Y).

GIM500R - 2-dimensional

2-dimensional, measuring range up to $\pm 90^\circ$

CANopen® / SAE J1939 / Analog

Dimensions

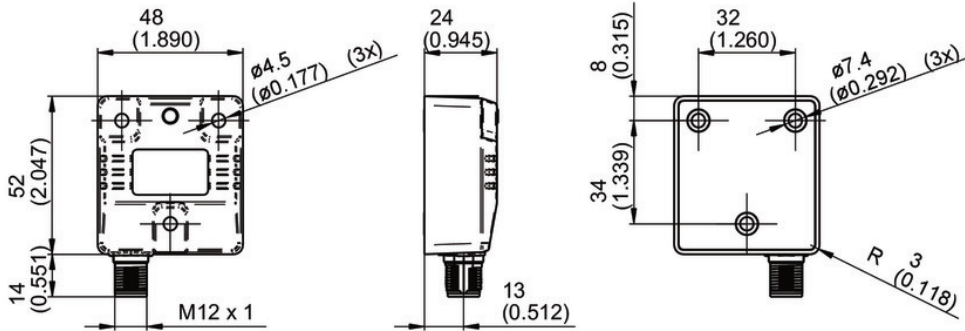

GIM500R - 1 x connector M12

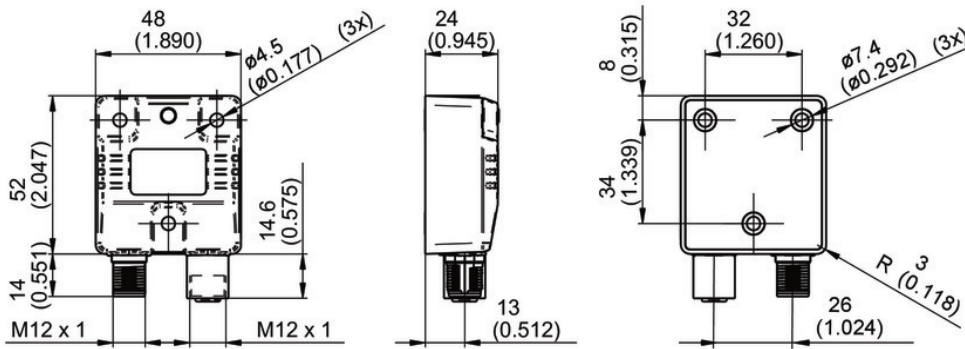

GIM500R - 2 x connector M12

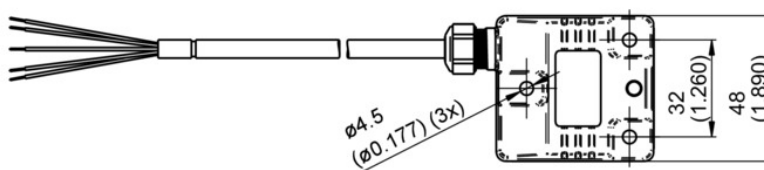
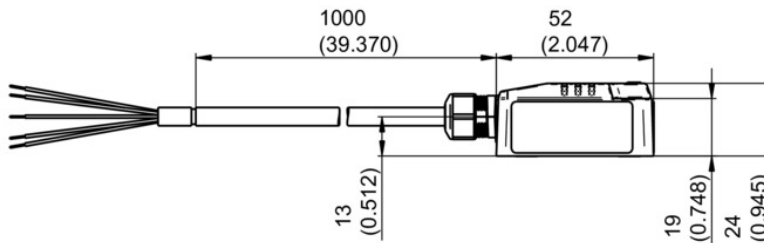
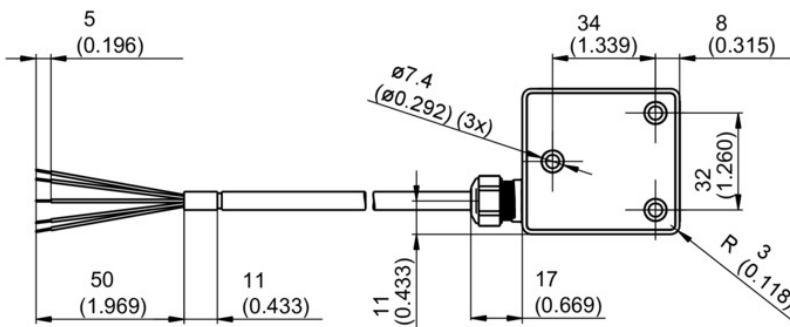

GIM500R - cable

GIM500R - 2-dimensional

 2-dimensional, measuring range up to $\pm 90^\circ$

CANopen® / SAE J1939 / Analog

Ordering reference

| | | GIM500R | - | M | # | ### | . | # | ## | . | A | ##### |
|---|--|---------|---|---|---|-----|---|---|----|---|---|-------|
| Product | | GIM500R | | | | | | | | | | |
| Housing | | | | | | | | | | | | |
| Metal | | | | M | | | | | | | | |
| Number of axes | | | | | | | | | | | | |
| 2-dimensional, housing horizontal | | | | | | 2 | | | | | | |
| 2-dimensional, housing vertical | | | | | | V | | | | | | |
| Measuring range | | | | | | | | | | | | |
| $\pm 10^\circ$ (Analog with zero setting) | | | | | | | | | | | | 10 |
| $\pm 30^\circ$ (Analog with zero setting) | | | | | | | | | | | | 30 |
| $\pm 45^\circ$ (Analog with zero setting) | | | | | | | | | | | | 45 |
| $\pm 60^\circ$ (Analog with zero setting) | | | | | | | | | | | | 60 |
| $\pm 90^\circ$ (Analog, CANopen®, SAE J1939) | | | | | | | | | | | | 90 |
| Connection | | | | | | | | | | | | |
| Cable 1 m, Standard 4x2x0.14 mm ² (Analog, CANopen®, SAE J1939) | | | | | | | | | | | | K |
| Flange connector M12, 5-pin, male contacts (CANopen®, SAE J1939) | | | | | | | | | | | | A |
| Flange connector 2xM12, 5-pin, male and female contacts (CANopen®, SAE J1939) | | | | | | | | | | | | B |
| Flange connector M12, 8-pin, male contact (Analog) | | | | | | | | | | | | F |
| Voltage supply / interface | | | | | | | | | | | | |
| 8...36 VDC / CANopen® | | | | | | | | | | | | C6 |
| 8...36 VDC / SAE J1939 | | | | | | | | | | | | C9 |
| 8...36 VDC / Analog 0.5...4.5 V | | | | | | | | | | | | V4 |
| 8...36 VDC / Analog 0...5 V | | | | | | | | | | | | V5 |
| 8...36 VDC / Analog 0...10 V | | | | | | | | | | | | V1 |
| 8...36 VDC / Analog 4...20 mA | | | | | | | | | | | | C4 |
| Operating temperature | | | | | | | | | | | | |
| -40...+85 °C | | | | | | | | | | | | A |
| Option | | | | | | | | | | | | |
| Without option | | | | | | | | | | | | |
| With integrated terminating resistor (CANopen, SAE J1939) | | | | | | | | | | | | /4816 |
| Output signal with out-of-range diagnostics (Analog) | | | | | | | | | | | | /4822 |

Accessories

Mounting accessories

| | |
|----------|---|
| 11120131 | Mounting kit 3x M4 x 25 DIN912, A 4.3 DIN125 |
| 11189609 | Mounting kit 3x M4 x 50 DIN912, A 4.3 DIN125, spacers |

Programming accessories

| | |
|----------|-------------------------------------|
| 11084376 | ZTEST-ALL.ANALOG |
| 11128719 | USB-to-CAN V2 adaptor, D-SUB, 9-pin |