

Reed Switch

selector guide



"our aim is to form close partnerships with our customers, working with them at all levels"

Reed Switches	Page
Standard & Miniature Switches	2
Sub Miniature & Tiny Switches	3
Changeover Switches	4
Reed Operating Coils	
Standard & Miniature coils	5
Permanent Magnets for Reed Switch Operation	
Magnet Types	6
Operating Distances	7
Reed Switch Application Notes	
Contact Protection	8 - 10



FM02050



For all your sales enquiries call...

UK +44 (0)1202 897969

USA + 1 (619) 210-1600

Reed Switch Standard & Miniature Switches

- Controlled switching environment.
- Low contact resistance variants.
- High power applications.
- High voltage.

A family of form 'A' reed switches produced with Rhodium contact material, designed to range from moderate currents and voltages through to high voltage, high current switching.



Parameters	Type	Standard size Normally Open						Miniature
		Standard	High Power			High Voltage		MRA560G
		DRA200G	DRA282G	DRA283	DRA500H	DTA500H	DTA810H	
Contact form		A	A	A	A	A	A	A
Contact material		Rh	Rh	Rh	Rh	T	T	Rh
Switching capacity	max. W/VA	80	120	250	25	50	50	100
Switching voltage	max. V AC/DC	250	250	250	500	1000	7500	1000
Switching current	max. A	1.3	*3.0	*5.0	1.5	2.5	3.0	1.0
Carrying current	max. A	2.0	5.0	5.0	-	-	-	2.5
Dielectric strength	min. VDC	800	800	575	2500	2500	10000	1500
Initial Contact resistance	max. mOhms	80	80	100	100	100	100	100
Insulation resistance	min. Ohms	10 ¹¹	10 ¹¹	10 ¹⁰	10 ⁸	10 ⁸	10 ¹⁰	10 ¹⁰
Operate sensitivity	range AT	75 ... 95	75 ... 95	60 ... 120	60 ... 100	60 ... 100	100 ... 150	20...40
Release sensitivity	min. AT	25	33.5	-	16	25	46	5
Operate time including bounce	max. ms	4.0	3.5	5.0	3.0	3.0	3.0	1.1
Bounce time	max. ms	0.5	0.5	1.0	0.5	0.5	1.0	0.5
Release time	max. ms	0.20	0.20	0.2	1.5	1.5	1.0	0.05
Resonant frequency	typ. Hz	900	900	900	-	-	-	2500
Operating frequency	max. Hz	100	100	-	-	-	-	500
Vibration	35 g Hz	500	500	-	-	-	-	2000
Shock	11 ms g	50	50	-	-	-	-	30
Capacitance	typ. pF	0.8	0.8	0.6	0.8	1.5	1.0	0.5
Operating temperature range	°C	-40...+150			0/+125			-40...+150

Dimensions

Overall length	A max.	mm	79	79	84	82	82	82	56
Glass length	B max.	mm	52	52	51	51	51	54	21
Glass diameter	C max.	mm	5.4	5.4	5.4	5.5	5.5	†5.5	2.8
Wire diameter	D nom.	mm	2.5x0.5	2.5x0.5	2.5x0.5	2.5x0.5	2.5x0.5	2.5x0.5	0.60

* Reduced life at high current.

† Plus Glass Pip 5.9 max.

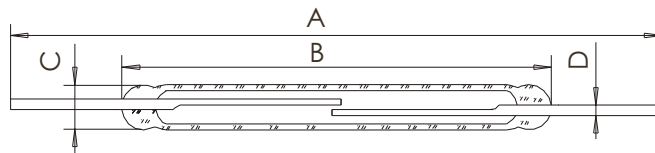

CONTACT US NOW

UNITED KINGDOM

CRYDOM

T +44 (0) 1202 897969

F +44 (0) 1202 891918

E magnetics@crydom.com

W www.crydom.co.uk

USA

CRYDOM

T +1 619 210 1600

F +1 619 710 8540

E sales@crydom.com

W www.crydom.com

standard & miniature
Reed Switches



Reed Switch

Sub Miniature & Tiny Switches

Form A

These tiny reed switches are designed for low power and high speed switching with maximum sensitivity. Their extremely small size make them ideal for Dual In Line packages, or magnet operation.

Form A

- Small physical size.
- Centre or offset contact configurations.
- High speed switching.

			NORMALLY OPEN						
			Sub-Miniature Normally Open			Tiny Size Normally Open		Very Tiny	
Parameters	Type		SRA200G	SRA258	SRA260G	TRA211G	TRA291G	TRA294G	VDA200H
Contact form			A	A	A	A	*A	A	A
Contact material			Rh	Rh	Rh	Rh	Rh	Rh	Durel
Switching capacity	max.	W/VA	12	12	40	1	10	10	.25
Switching voltage	max.	VAC/DC	230	230	230	24	100	150	30
Switching current	max.	A	1.0	1.0	2.0	0.1	0.3	.5	0.01
Carrying current	max.	A	2.0	2.0	3.0	0.3	1.0	1.0	-
Dielectric strength	min.	VDC	400	400	400	150	200	250	150
Initial Contact resistance	max.	mohms	100	100	80	150	150	150	500
Insulation resistance	min.	ohms	10 ¹¹	10 ¹⁴	10 ¹¹	10 ⁹	10 ⁹	10 ¹⁰	10 ⁹
Operate sensitivity	range	AT	20...50	20...50	30...50	10..30	10..40	15...35	5...20
Release sensitivity	min.	AT	5	5	15	5	5	5	3
Operate time									
including bounce	max.	ms	2.5	2.5	2.5	0.6	0.8	2.0	0.2
Bounce time	max.	ms	0.5	0.5	0.5	0.3	0.5	0.2	0.08
Release time	max.	ms	0.10	0.10	0.10	0.05	0.05	0.05	0.05
Resonant frequency	typ.	Hz	2,900	2,900	4,200	7,500	2750	5,000	-
Operating frequency	max.	Hz	200	200	300	500	500	200	-
Vibration	35 g	Hz	2,000	2,000	2,000	2,000	-	2,000	-
Shock	11ms	g	50	50	50	30	30	50	-
Capacitance	typ.	pF	0.5	0.5	0.5	0.2	0.3	0.7	0.2
Operating temperature range	°C		-40...+150			-40...+125		-40...+150	-40...+125

Dimensions									
Total length	A max.	mm	55.0	55.0	55.0	36.0	44.5	55.0	26.7
Glass length	B max.	mm	19.0	19.0	19.0	10.0	13.0	14.1	5.4
Glass diameter	C max.	mm	2.6	2.6	2.6	2.0	2.3	2.3	1.4
Wire diameter	D nom.	mm	0.55	0.55	0.70	0.40	0.35x0.6	0.50	0.25

* Offset Contact Configuration

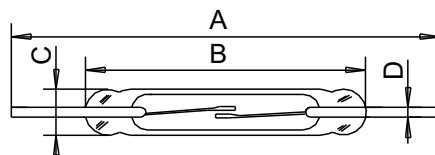

sub miniature & tiny
Reed Switches



Reed Switch Changeover Switches

- Changeover or normally closed application.
- Inert gas atmosphere.

A family of form 'C' reed switches offers moderate to medium voltage breakdown.



Parameters	Type	Compact Change Over			Tiny Change Over	
		Standard	High Power		TRC200B	TRC200S
		CRC200H	CRC500H	CTC500H		
Contact form		C	C	C	C	C
Contact material		Rh	Rh	T	Rh	Rh
Switching capacity	max. W/VA	25	25	100#	5	5
Switching voltage	max. V AC/DC	150	250	500	175	175
Switching current	max. A	1.0	1.0	3.0	0.25	0.25
Carrying current	max. A	-	-	-	0.5	0.5
Dielectric strength	min. VDC	250	1000	1000	200	200
Initial contact resistance	max. mohms	100	100	500	100	100
Insulation resistance	min. ohms	10 ¹⁰	10 ⁸	10 ⁸	10 ⁹	10 ⁹
Operate sensitivity	range AT	40 ... 80	50 ... 90	60 ... 100	15 ... 30	15 ... 30
Release sensitivity	min. AT	10	30	32	-	-
Operate time						
without bounce	max. ms	3.0	3.0	3.5	0.7	0.7
Bounce time	max. ms	1.0	1.0	1.5	-	-
Release time	max. ms	2.0	1.0	1.0	1.0	1.0
Resonant frequency	typ. Hz	-	-	-	11000	11000
Operating frequency	max. Hz	-	-	-	-	-
Vibration	35 g Hz	-	-	-	30g@50-2k Hz	30g@50-2k Hz
Shock	11 ms g	-	-	-	50	50
Capacitance	typ. pF	2.0	2.0	-	-	-
Operating temperature range	°C	-40...+150	0/+125		-40/+125	

Dimensions

Overall length	A max.	mm	87	87	87	53	53
Glass length	B max.	mm	35	35	35	14.8	14.8
Glass diameter	C max.	mm	5.4	5.4	5.4	2.7	2.7
Wire diameter	D max.	mm	1.0	1.0	1.0	0.51	0.51

Compact Change Over

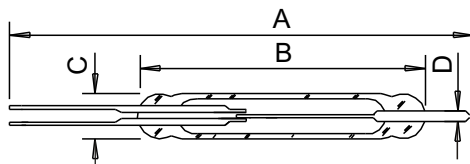

Tiny Change Over

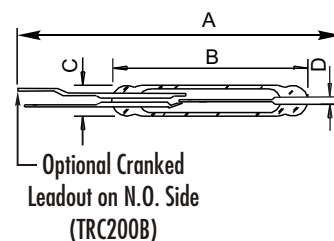

CONTACT US NOW

UNITED KINGDOM

CRYDOM

T +44 (0) 1202 897969

F +44 (0) 1202 891918

E magnetics@crydom.com

W www.crydom.co.uk

USA

CRYDOM

T +1 619 210 1600

F +1 619 710 8540

E sales@crydom.com

W www.crydom.com

changeover
Reed Switches



Reed Operating Coils

Operating coils for Standard and Miniature size reed switches are available for customer assembly of Reed Relays. Coils are made in two widths to take wither one or two reed switches.

Crydom Magnetics specialise in producing custom designs, so other variations and options may be available to suit particular requirements.

Details of Crydom Magnetics Reed Switches are listed on separate sheets, available on request.

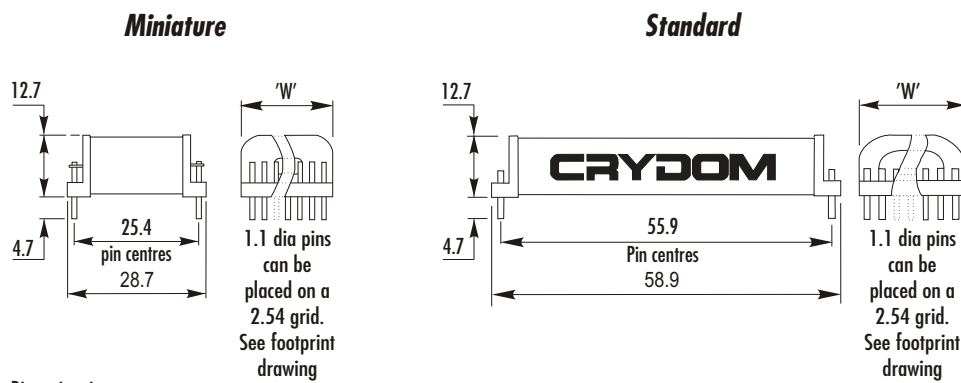

Dimensions in mm.

Coil Type M	Voltage	Coil Resistance	Footprint View from top
MS05	5Vdc	155 Ohms	
MS12	12 Vdc	930 Ohms	
MS24	24 Vdc	3500 Ohms	
MD05	5Vdc	78 Ohms	
MD12	12 Vdc	435 Ohms	
MD24	24 Vdc	1875 Ohms	

Coil Type S	Voltage	Coil Resistance	Footprint View from top
SS05	5Vdc	120 Ohms	
SS12	12 Vdc	635 Ohms	
SS24	24 Vdc	3100 Ohms	
SD05	5Vdc	48 Ohms	
SD12	12 Vdc	400 Ohms	
SD24	24 Vdc	1455 Ohms	

Coil size	No. of reeds	W	H	Rx Sensitivity
MS	1	12.7	14.6	30-40
MD	2	18.3	16.4	30-40

Coil size	No. of reeds	W	H	Rx Sensitivity
SS	1	12.7	15.2	50-60
SD	2	18.3	16.4	50-60

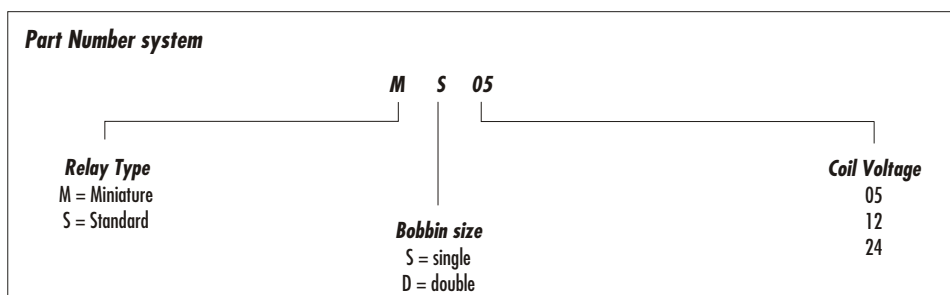

reed operating coils



Permanent Magnets for Reed Switch Operation

A range of magnets is available for operating the Crydom Magnetics range of reed switches. The selection of the correct combination of magnets and reeds switches, for a particular application, will normally be made on an empirical basis as intricate calculations are not necessary.

The following table of magnet types and accompanying graphs act as a guide to the relationship between switch sensitivity and magnet type. These figures can only be taken as a rough indication, due to the fact that magnets are manufactured to commercial tolerances.

Details of Crydom Magnetics Reed Switches are listed on separate sheets, available on request.

Magnet Types

Type Number	Nominal Dimensions mm/ins						Total Magnetic Flux μWb
	Length 'A'		Length 'B'		Length 'C'		
	mm	inches	mm	inches	mm	inches	
RSH01	12.7	0.5	3.2	0.125	1.6	0.063	4.0
RSH02	31.7	1.25	6.4	0.25	6.4	0.25	28
RSH32	27.9	1.10	4.8	0.187	4.8	0.187	22
RSH33	19.1	0.75	3.2	0.125	3.2	0.125	9
RSH34	25.4	1.00	6.4	0.25	6.4	0.25	30
RSH73	12.7	0.5	3.2	Diameter 0.125			5.5
RSH74	52.9	2.08	10.2	Diameter 0.40			71

All of these magnets are polarised along their length.

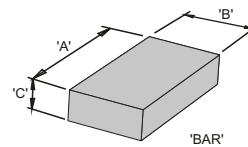
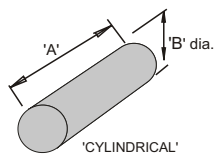

Actuation of Reed Switches with a Permanent Magnet

Direct Actuation:

A magnet moved perpendicularly towards and away from a Reed Switch turns it on and off once.

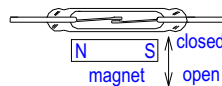

A magnet moved parallel to a Reed Switch operates it from one to three times.

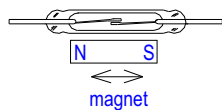

A magnet swung towards and away from a Reed Switch operates it once.

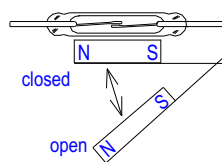

A ring magnet moved parallel to the Reed Switch axis operates it from one to three times.

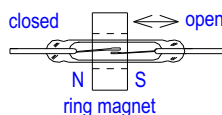

Rotation:

Examples of switching through rotational movement:

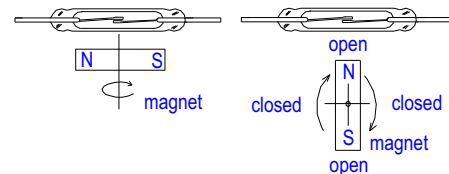

Indirect Actuation: Shielding

With the stationary arrangement of a Reed Switch and magnet, the reed contacts are closed. Should the magnetic field be diverted away from the Reed Switch by a shield of ferro-magnetic material placed between the switch and the magnet, the contacts will open. When the shield is removed, the reed contacts become magnetically actuated and close.

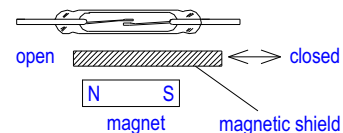

CONTACT US NOW
UNITED KINGDOM
CRYDOM

T +44 (0) 1202 897969
F +44 (0) 1202 891918
E magnetics@crydom.com
W www.crydom.co.uk

USA
CRYDOM

T +1 619 210 1600
F +1 619 710 8540
E sales@crydom.com
W www.crydom.com

permanent magnets for
Reed Switch operation

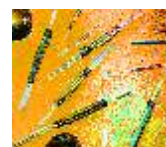

Operating graphs for Direct Actuation

NB Magnet parallel to reed switch and moving in perpendicular direction. Distance is between outside of reed switch and face of magnet.

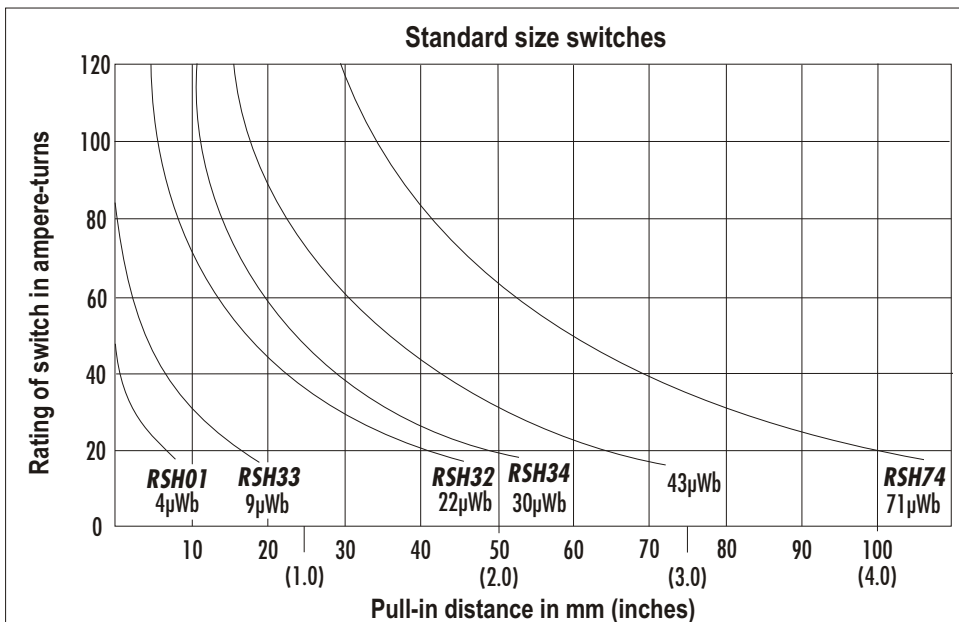
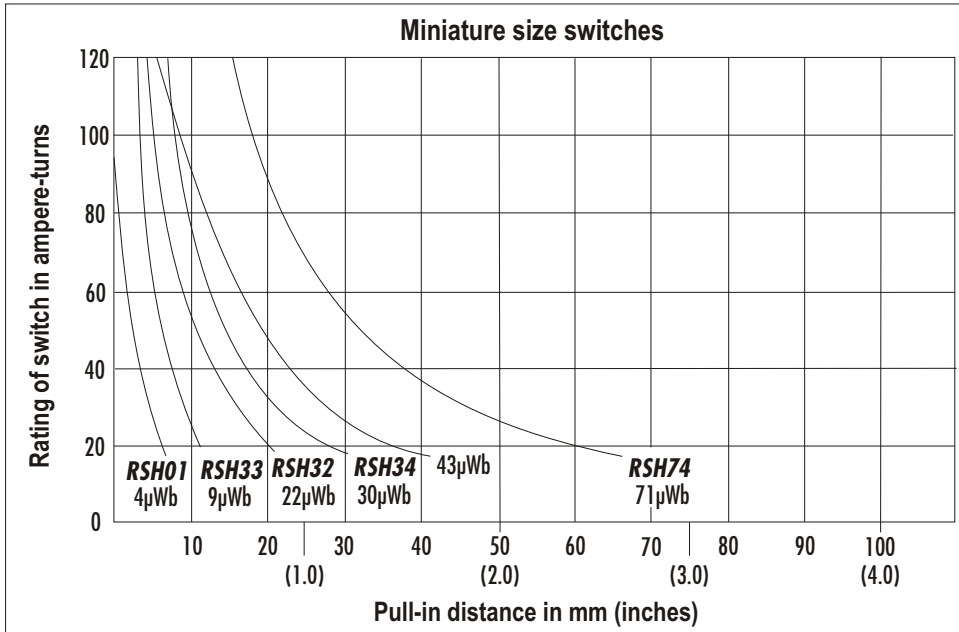

**permanent magnets for
Reed Switch operation**

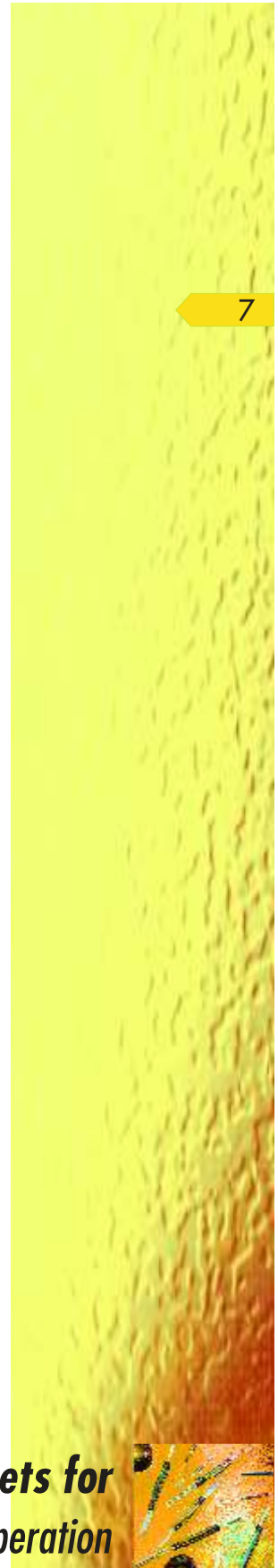

Reed Switch Application Notes

Contact Protection

The upper nomograph can be used for determining contact arc suppression for inductive loads.

Example 1: $I = 0,1 \text{ A}$
 $V = 230 \text{ V}$
 $C = 0,001 \text{ microfarads}$
 $R = 340 \text{ ohms}$

Example 2:
 If the current inrush is critical use the lower nomograph to determine the minimum resistance.

$I = 0,5 \text{ A}$
 $R_{min} = 400 \text{ ohms}$

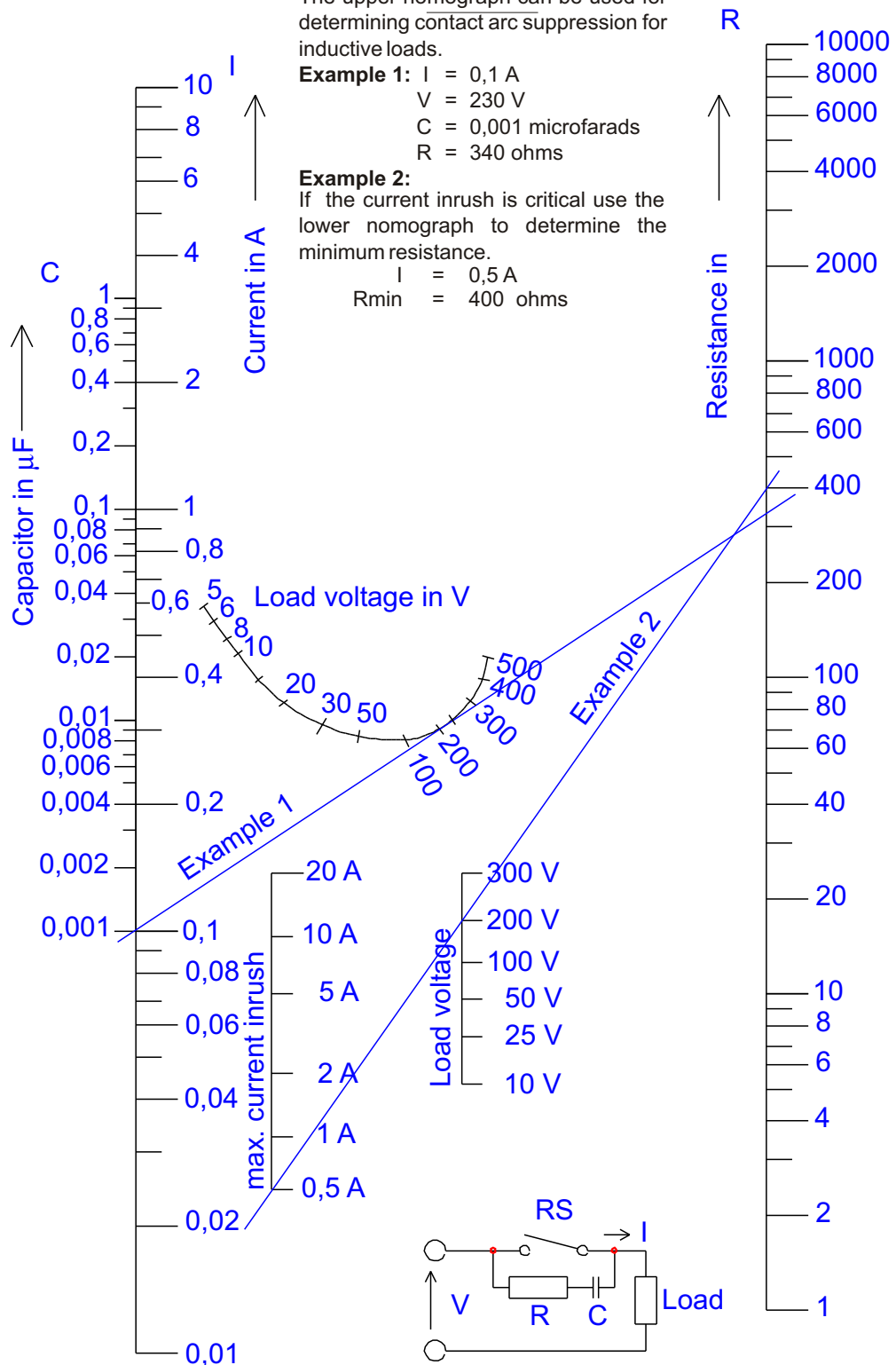

CONTACT US NOW
UNITED KINGDOM
CRYDOM
T +44 (0) 1202 897969
F +44 (0) 1202 891918
E magnetics@crydom.com
W www.crydom.co.uk

USA
CRYDOM
T +1 619 210 1600
F +1 619 710 8540
E sales@crydom.com
W www.crydom.com

Reed Switch

Application Notes

Capacitive Loads

Unlike inductive loads, capacitive and lamp loads are prone to high inrush currents which can lead to faulty operation and even contact welding. When switching charged capacitors (including cable capacitance) a sudden unloading can occur, the intensity of which is determined by the capacity and length of the connecting leads to the switch. This inrush peak can be reduced by a series of resistors. The value of these resistors is dependent on the particular application but should be as high as possible to ensure that the inrush current is within the allowable limits.

The diagram illustrates a resistor/capacitor network for protecting a Reed Switch against high inrush currents. R1 and/or R2 are used depending upon circuit conditions.

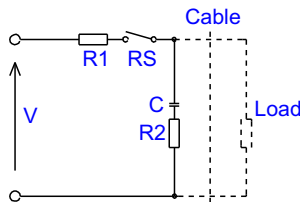

With lamp load applications it is important to note that cold lamp filaments have a resistance 10 times smaller than already glowing filaments. This means that when being turned-on, the lamp filament experiences a current flow 10 times greater than when already hot. This high inrush current can be reduced to an acceptable level through the use of a series of current-limiting resistors. Another possibility is to fit a resistor across the switch. This allows just enough current to flow through the filament to keep it warm, yet not enough to make it glow.

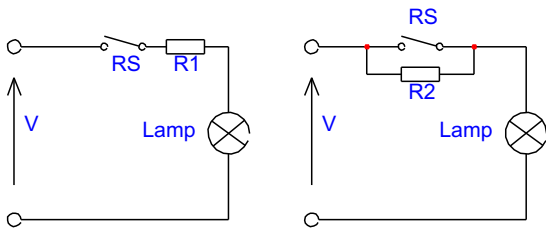

Lamp load with parallel or current limiting resistor across the switch

Cutting and Bending

As the Reed Switch blades form part of a magnetic circuit, shortening the leads results in increased pull-in and drop-out values.

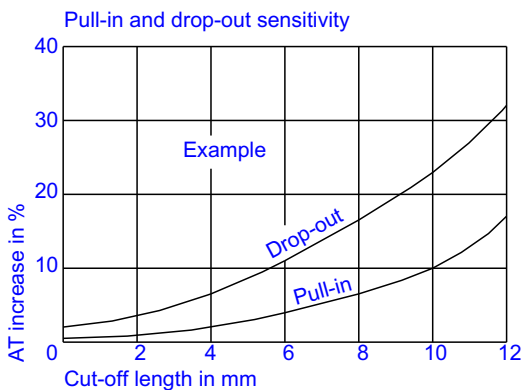

When cutting or bending Reed Switches, it is important that the glass body is not damaged. Therefore, the cutting or bending point should be no closer than 3 mm to the glass body and the leads should be supported when cutting or bending as shown.

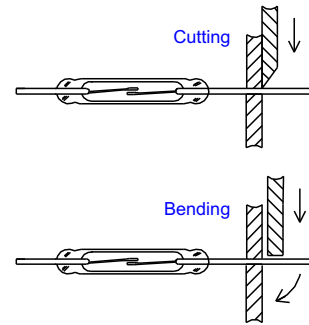

Actuation of Reed Switches with a Permanent Magnet

Examples of switching with the use of a moving magnet

Direct Actuation:

A magnet moved perpendicularly towards and away from a Reed Switch turns it on and off once.

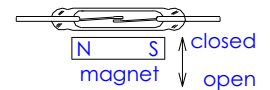

A magnet moved parallel to a Reed Switch operates it from one to three times.

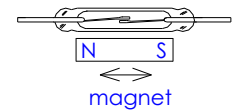

A magnet swung towards and away from a Reed Switch operates it once.

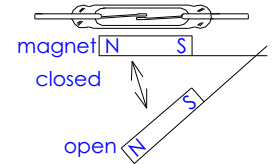

A ring magnet moved parallel to the Reed Switches axis operates it from one to three times.

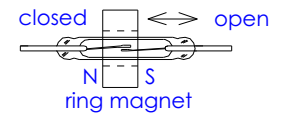

Rotation:

Examples of switching through rotational movement:

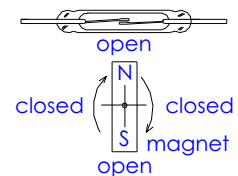
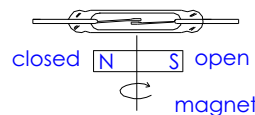

Indirect Actuation: Shielding

With the stationary arrangement of a Reed Switch and magnet, the reed contacts are closed. Should the magnetic field be diverted away from the Reed Switch by a shield of ferro-magnetic material placed between the switch and the magnet, the contacts will open. When the shield is removed, the reed contacts become magnetically actuated and close.

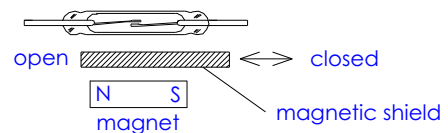

Reed Switch Application Notes

Permanent Magnet areas of Operation

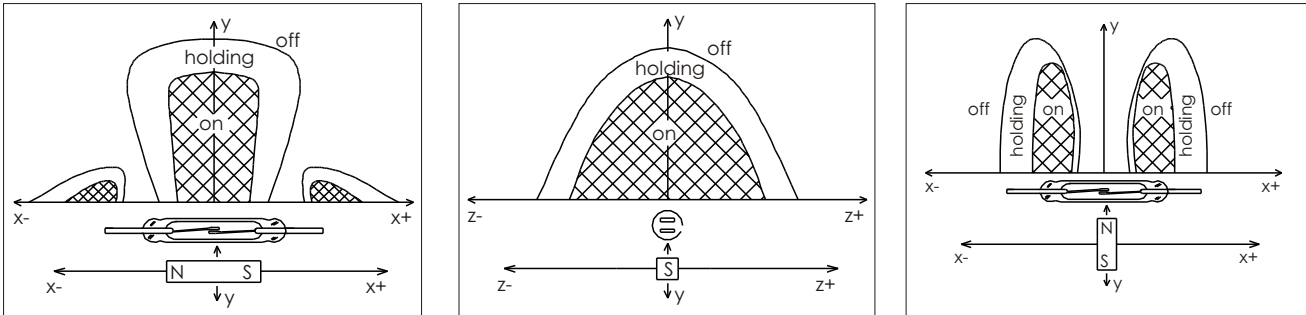

Magnets

The materials used for Reed Switch magnets are generally ALNICO (an aluminium nickel cobalt alloy), ceramic (barium ferrite or another metal oxide) or rare earth magnets. Due to their specific magnetic characteristics, the types of magnets differ in shape: ALNICO magnets are bar magnets with a length/diameter ratio of 3/1 to 5/1; oxide magnets are generally disc or moulded magnets. Also important to note is the difference in temperature coefficient: ALCO: 0.02 %/K, oxide: 0.2 %/K

In General:

The sensitivity of a reed switch is a measurement of the magnetic energy required to operate the switch. The unit of measurement is Ampere-Turns(AT), which is the current in a given coil multiplied the number of turns on that coil.

Manufacturers of reed switches will set their machines such that they aim to produce a particular operate AT but, due to tolerances in materials, machinery and operator control, the switches produced will have a range of operate AT. The reed switches are then measured and sorted into bands of AT, and stocked in those bands.

For each Reed Switch type the available range of operate sensitivity is given in the data table.

Other operate sensitivities are available on request.

Life Expectancy:

The life expectancy of a Reed Switch is about 10^5 ... 10^6 switching cycles with maximum power. With a low load the life expectancy can reach 5×10^8 operations. The mechanical life expectancy can reach at least 10^9 operations. The Life Expectancy is considerably reduced, through the switching of Inductive, Capacitive and Lamp loads, due to the maximum current being exceeded.

Pull In Sensitivity Tolerance:

The given operate sensitivity of the Reed Switch has a test equipment tolerance of ± 2 AT.

Approvals:

Similar switch types can be supplied with UL & CSA approvals on request.

Part Number system

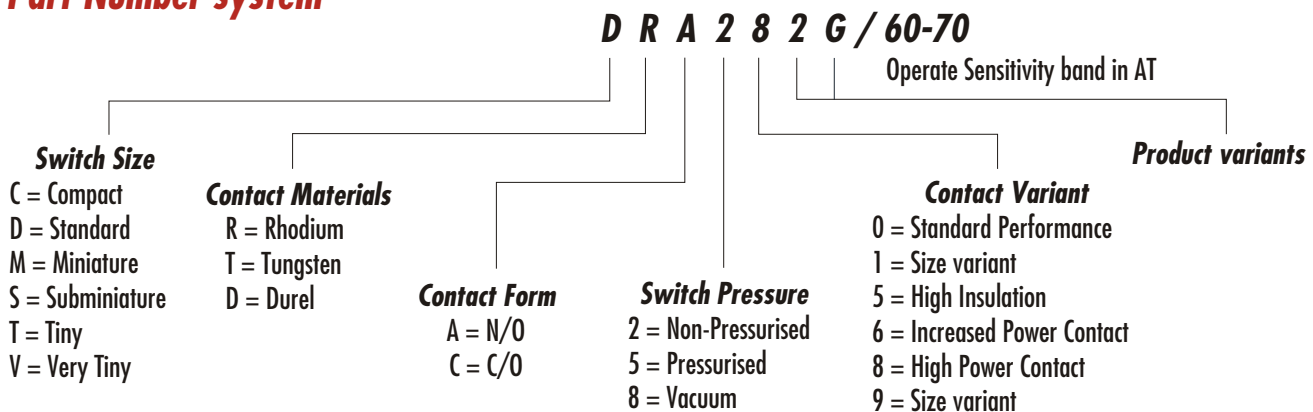

Example :

DRA282G = Standard size - Rhodium contact - N/O - Non-pressurised - High Power Contact - Operate Sensitivity 60 - 70 AT.