



# QuadDie DDR3 SDRAM

**MT41J4G4 – 128 Meg x 4 x 8 Banks x 4 Ranks**
**MT41J2G8 – 64 Meg x 8 x 8 Banks x 4 Ranks**

## Features

- Uses 4Gb Micron die
- Four ranks (includes four CS#, ZQ, and dual ODT, CKE balls)
- Each rank has eight internal banks for concurrent operation
- $V_{DD} = V_{DDQ} = 1.5V \pm 0.075V$
- 1.5V center-terminated push/pull I/O
- JEDEC-standard ball-out
- Low-profile package
- $T_C$  of 0°C to 95°C
  - 0°C to 85°C: 8192 refresh cycles in 64ms
  - 85°C to 95°C: 8192 refresh cycles in 32ms

## Description

The 16Gb QuadDie DDR3 SDRAM uses Micron's 4Gb DDR3 die and has similar functionality. This data sheet includes key timing parameters, ball assignments, a functional description, functional block diagrams,  $I_{DD}$  specifications, and package dimensions. Specifications for the base part numbers are MT41J1GM4 and MT41J512M8.

## Options

- Configuration
  - 128 Meg x 4 x 8 banks x 4 ranks 4G4
  - 64 Meg x 8 x 8 banks x 4 ranks 2G8
- FBGA package (Pb-free) SMA
  - 78-ball FBGA (9.5mm x 11.5mm x 1.45mm)
- Timing – cycle time<sup>1</sup>
  - 1.25ns @ CL = 11 (DDR3-1600) -125
  - 1.5ns @ CL = 9 (DDR3-1333) -15E
  - 1.87ns @ CL = 7 (DDR3-1066) -187E
- Self refresh
  - Standard None
- Operating temperature
  - Commercial (0°C ≤  $T_C$  ≤ 95°C) None
- Revision :E

Note: 1. CL = CAS (READ) latency.

**Table 1: Key Timing Parameters**

Speed Grade	Data Rate (MT/s)	Target $t_{RCD}$ - $t_{RP}$ -CL	$t_{RCD}$ (ns)	$t_{RP}$ (ns)	$t_{CL}$ (ns)
-125 <sup>1,2</sup>	1600	11-11-11	13.75	13.75	13.75
-15E <sup>1</sup>	1333	9-9-9	13.5	13.5	13.5
-187E	1066	7-7-7	13.1	13.1	13.1

- Notes: 1. Backward compatible to 1066, CL = 7 (-187E).  
2. Backward compatible to 1333, CL = 9 (-15E).

**Table 2: Addressing**

Parameter	4 Gig x 4	2 Gig x 8
Configuration	128 Meg x 4 x 8 banks x 4 ranks	64 Meg x 8 x 8 banks x 4 ranks
Refresh count	8K	8K
Row address	64K A[15:0]	64K A[15:0]
Bank address	8 BA[2:0]	8 BA[2:0]
Column address	2K A[11, 9:0]	1K A[9:0]



# 16Gb: x4, x8 QuadDie DDR3 SDRAM Ball Assignments and Descriptions

## Ball Assignments and Descriptions

Figure 1: 78-Ball FBGA Ball Assignments (Top View)

	1	2	3	4	5	6	7	8	9
A	V <sub>SS</sub>	V <sub>DD</sub>	NC				NF, NF/TDQS#	V <sub>SS</sub>	V <sub>DD</sub>
B	V <sub>SS</sub>	V <sub>SSQ</sub>	DQ0				DM, DM/TDQS	V <sub>SSQ</sub>	V <sub>DDQ</sub>
C	V <sub>DDQ</sub>	DQ2	DQS				DQ1	DQ3	V <sub>SSQ</sub>
D	V <sub>SSQ</sub>	NF, DQ6	DQS#				V <sub>DD</sub>	V <sub>SS</sub>	V <sub>SSQ</sub>
E	V <sub>REFDQ</sub>	V <sub>DDQ</sub>	NF, DQ4				NF, DQ7	NF, DQ5	V <sub>DDQ</sub>
F	ODT1	V <sub>SS</sub>	RAS#				CK	V <sub>SS</sub>	CKE1
G	ODT0	V <sub>DD</sub>	CAS#				CK#	V <sub>DD</sub>	CKE0
H	CS1#	CS0#	WE#				A10/AP	ZQ0	ZQ1
J	V <sub>SS</sub>	BA0	BA2				A15	V <sub>REFCA</sub>	V <sub>SS</sub>
K	CS2#	A3	A0				A12/BC#	BA1	ZQ2
L	CS3#	A5	A2				A1	A4	ZQ3
M	V <sub>DD</sub>	A7	A9				A11	A6	V <sub>DD</sub>
N	V <sub>SS</sub>	RESET#	A13				A14	A8	V <sub>SS</sub>

Note: 1. Dark balls (with ring) designate balls that differ from the monolithic versions.



## 16Gb: x4, x8 QuadDie DDR3 SDRAM Ball Assignments and Descriptions

**Table 3: FBGA 78-Ball Descriptions**

Symbol	Type	Description
A[15:13], A12/BC#, A11, A10/AP, A[9:0]	Input	<b>Address inputs:</b> Provide the row address for ACTIVATE commands, and the column address and auto precharge bit (A10) for READ/WRITE commands, to select one location out of the memory array in the respective bank. A10 sampled during a PRECHARGE command determines whether the PRECHARGE applies to one bank (A10 LOW, bank selected by BA[2:0]) or all banks (A10 HIGH). The address inputs also provide the op-code during a LOAD MODE command. Address inputs are referenced to $V_{\text{REFCA}}$ . A12/BC#: When enabled in the mode register (MR), A12 is sampled during READ and WRITE commands to determine whether burst chop (on-the-fly) will be performed (HIGH = burst length (BL) of 8 or no burst chop, LOW = burst chop (BC) of 4, burst chop).
BA[2:0]	Input	<b>Bank address inputs:</b> BA[2:0] define the bank to which an ACTIVATE, READ, WRITE, or PRECHARGE command is being applied. BA[2:0] define which mode register (MR0, MR1, MR2, or MR3) is loaded during the LOAD MODE command. BA[2:0] are referenced to $V_{\text{REFCA}}$ .
CK, CK#	Input	<b>Clock:</b> CK and CK# are differential clock inputs. All command, address, and control input signals are sampled on the crossing of the positive edge of CK and the negative edge of CK#. Output data strobe (DQS, DQS#) is referenced to the crossings of CK and CK#.
CKE[1:0]	Input	<b>Clock enable:</b> CKE enables (registered HIGH) and disables (registered LOW) internal circuitry and clocks on the DRAM. The specific circuitry that is enabled/disabled is dependent upon the DDR3L SDRAM configuration and operating mode. Taking CKE LOW provides PRECHARGE power-down and SELF REFRESH operations (all banks idle) or active power-down (row active in any bank). CKE is synchronous for power-down entry and exit and for self refresh entry. CKE is asynchronous for self refresh exit. Input buffers (excluding CK, CK#, CKE, RESET#, and ODT) are disabled during power-down. Input buffers (excluding CKE and RESET#) are disabled during SELF REFRESH. CKE is referenced to $V_{\text{REFCA}}$ .
CS#[3:0]	Input	<b>Chip select:</b> CS# enables (registered LOW) and disables (registered HIGH) the command decoder. All commands are masked when CS# is registered HIGH. CS# provides for external rank selection on systems with multiple ranks. CS# is considered part of the command code.
DM	Input	<b>Input data mask:</b> DM is an input mask signal for write data. Input data is masked when DM is sampled HIGH, along with the input data, during a write access. Although the DM ball is input-only, the DM loading is designed to match that of the DQ and DQS balls. DM is referenced to $V_{\text{REFDQ}}$ . DM has an optional use as TDQS on the x8.
ODT[1:0]	Input	<b>On-die termination:</b> ODT enables (registered HIGH) and disables (registered LOW) termination resistance internal to the DDR3L SDRAM. When enabled in normal operation, ODT is only applied to each of the following balls: DQ[7:0], DQS, DQS#, and DM for the x8; DQ[3:0], DQS, DQS#, and DM for the x4. The ODT input is ignored if disabled via the LOAD MODE command. ODT is referenced to $V_{\text{REFCA}}$ .
RAS#, CAS#, WE#	Input	<b>Command inputs:</b> RAS#, CAS#, and WE# (along with CS#) define the command being entered and are referenced to $V_{\text{REFCA}}$ .
RESET#	Input	<b>Reset:</b> RESET# is an active LOW CMOS input referenced to $V_{\text{SS}}$ . The RESET# input receiver is a CMOS input defined as a rail-to-rail signal with DC HIGH $\geq 0.8 \times V_{\text{DDQ}}$ and DC LOW $\leq 0.2 \times V_{\text{DDQ}}$ . RESET# assertion and desertion are asynchronous.
DQ[3:0]	I/O	<b>Data input/output:</b> Bidirectional data bus for x4 configuration. DQ[3:0] are referenced to $V_{\text{REFDQ}}$ .



## 16Gb: x4, x8 QuadDie DDR3 SDRAM Ball Assignments and Descriptions

**Table 3: FBGA 78-Ball Descriptions (Continued)**

Symbol	Type	Description
DQ[7:0]	I/O	<b>Data input/output:</b> Bidirectional data bus for x8 configuration. DQ[7:0] are referenced to $V_{REFDQ}$ .
DQS, DQS#	I/O	<b>Data strobe:</b> DQS and DQS# are differential data strobes: Output with read data; edge aligned with read data; input with write data; center-aligned with write data.
TDQS, TDQS#	I/O	<b>Termination data strobe:</b> Applies to the x8 configuration only. When TDQS is enabled, DM is disabled, and the TDQS and TDQS# balls provide termination resistance.
$V_{DD}$	Supply	<b>Power supply:</b> $V_{DD} = V_{DDQ} = 1.5V \pm 0.075V$ .
$V_{DDQ}$	Supply	<b>DQ power supply:</b> $V_{DD} = V_{DDQ} = 1.5V \pm 0.075V$ . Isolated on the device for improved noise immunity.
$V_{REFCA}$	Supply	<b>Reference voltage for control, command, and address:</b> $V_{REFCA}$ must be maintained at all times (including self refresh) for proper device operation.
$V_{REFDQ}$	Supply	<b>Reference voltage for data:</b> $V_{REFDQ}$ must be maintained at all times (including self refresh) for proper device operation.
$V_{SS}$	Supply	Ground.
$V_{SSQ}$	Supply	<b>DQ ground:</b> Isolated on the device for improved noise immunity.
ZQ[3:0]	Reference	<b>External reference ball for output drive calibration:</b> This ball is tied to an external 240 $\Omega$ resistor (RZQ), which is tied to $V_{SSQ}$ .
NC	–	<b>No connect:</b> These balls should be left unconnected (the ball has no connection to the DRAM or to other balls).
NF	–	<b>No function:</b> When configured as a x4 device, these balls are NF. When configured as a x8 device, these balls are defined as TDQS#, DQ[7:4].



## Functional Description

The QuadDie DDR3 SDRAM is a high-speed, CMOS dynamic random access memory device internally configured as two 8-bank DDR3 SDRAM devices.

Although each die is tested individually within the quad-die package, some QuadDie test results may vary from a like-die tested within a monolithic die package.

The DDR3 SDRAM uses a double data rate architecture to achieve high-speed operation. The double data rate architecture is an  $8n$ -prefetch architecture with an interface designed to transfer two data words per clock cycle at the I/O balls. A single read or write access consists of a single  $8n$ -bit-wide, one-clock-cycle data transfer at the internal DRAM core and eight corresponding  $n$ -bit-wide, one-half-clock-cycle data transfers at the I/O balls.

The differential data strobe (DQS, DQS#) is transmitted externally, along with data, for use in data capture at the DDR3 SDRAM input receiver. DQS is center-aligned with data for WRITES. The read data is transmitted by the DDR3 SDRAM and edge-aligned to the data strobes.

Read and write accesses to the DDR3 SDRAM are burst oriented. Accesses start at a selected location and continue for a programmed number of locations in a programmed sequence. Accesses begin with the registration of an ACTIVATE command, which is then followed by a READ or WRITE command. The address bits registered coincident with the ACTIVATE command are used to select the bank and row to be accessed. The address bits (including  $CSn\#$ ,  $BA_n$ , and  $AN$ ) registered coincident with the READ or WRITE command are used to select the rank, bank, and starting column location for the burst access.

This data sheet provides a general description, package dimensions, and the package ballout. Refer to the Micron monolithic DDR3 data sheet for complete information regarding individual die initialization, register definition, command descriptions, and die operation.



# 16Gb: x4, x8 QuadDie DDR3 SDRAM Functional Block Diagrams

## Functional Block Diagrams

Figure 2: Functional Block Diagram (1 Gb x 4 x 8 Banks x 4 Ranks)

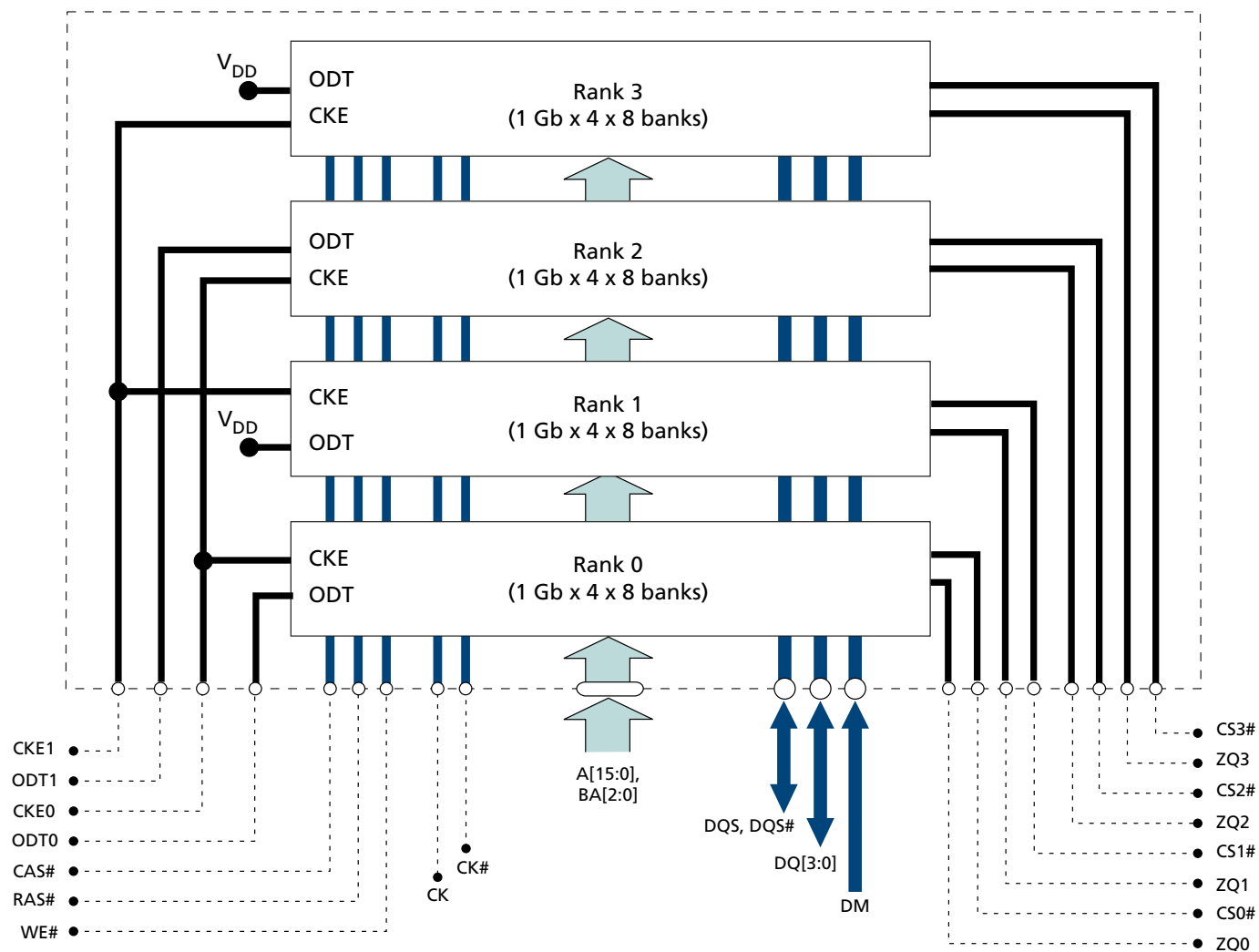



# 16Gb: x4, x8 QuadDie DDR3 SDRAM Functional Block Diagrams

**Figure 3: Functional Block Diagram (512 Meg x 8 x 8 Banks x 4 Ranks)**

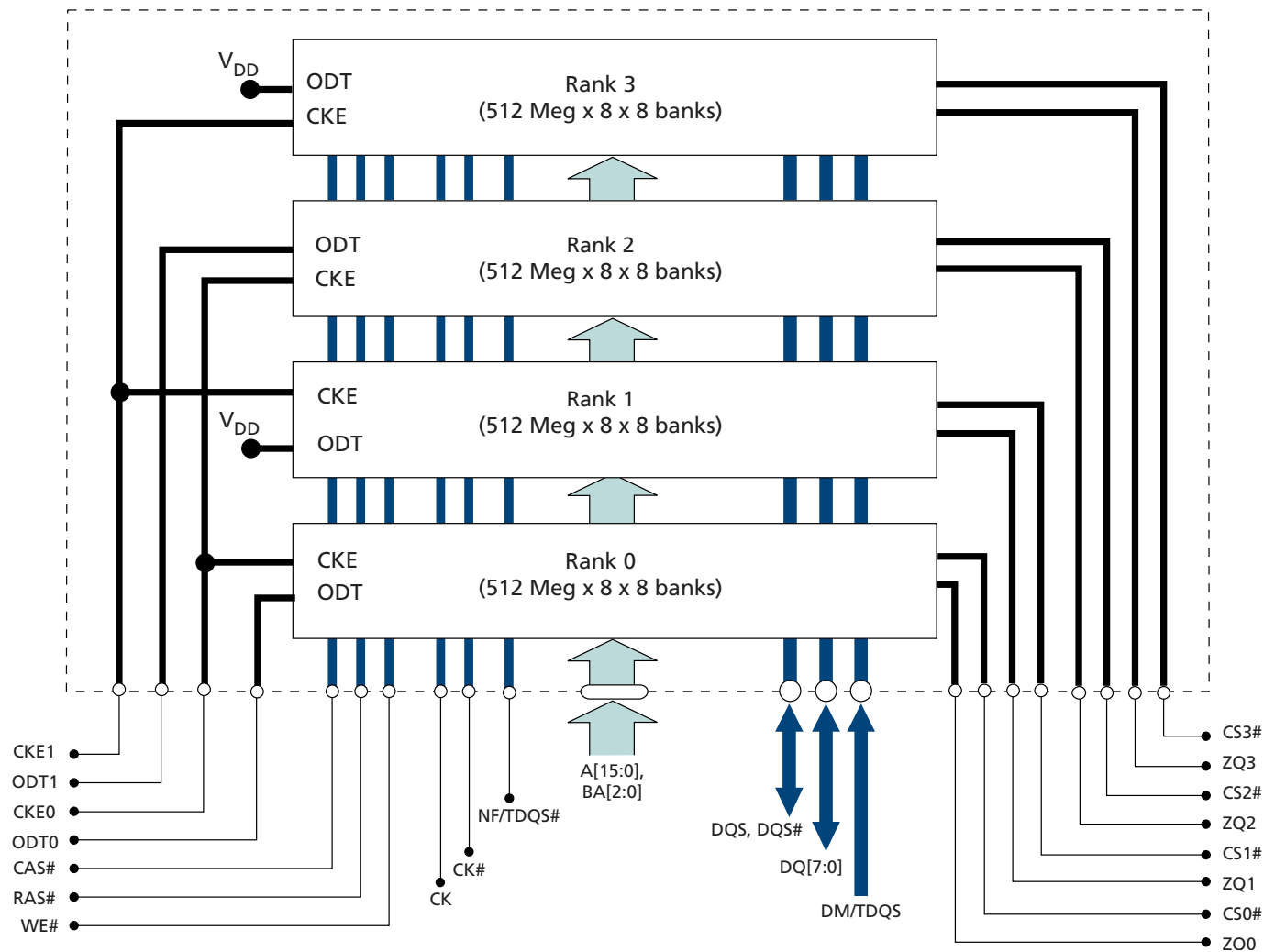



## 16Gb: x4, x8 QuadDie DDR3 SDRAM Electrical Specifications – Absolute Ratings

### Electrical Specifications – Absolute Ratings

Stresses greater than those listed may cause permanent damage to the device. This is a stress rating only, and functional operation of the device at these or any other conditions outside those indicated in the device data sheet is not implied. Exposure to absolute maximum rating conditions for extended periods may adversely affect reliability.

**Table 4: Absolute Maximum DC Ratings**

Parameter	Symbol	Min	Max	Units	Notes
$V_{DD}$ supply voltage relative to $V_{SS}$	$V_{DD}$	-0.4	1.975	V	1
$V_{DD}$ supply voltage relative to $V_{SSQ}$	$V_{DDQ}$	-0.4	1.975	V	
Voltage on any ball relative to $V_{SS}$	$V_{IN}, V_{OUT}$	-0.4	1.975	V	
Input leakage current Any input $0V \leq V_{IN} \leq V_{DD}$ , $V_{REF}$ pin $0V \leq V_{IN} \leq 1.1V$ (All other pins not under test = 0V)	$I_I$	-8	8	$\mu A$	
$V_{REF}$ supply leakage current $V_{REFDQ} = V_{DD}/2$ or $V_{REFCA} = V_{DD}/2$ (All other pins not under test = 0V)	$I_{VREF}$	-4	4	$\mu A$	2
Operating case temperature	$T_C$	0	95	$^{\circ}C$	3, 4
Storage temperature	$T_{STG}$	-55	150	$^{\circ}C$	

- Notes:
- $V_{DD}$  and  $V_{DDQ}$  must be within 300mV of each other at all times, and  $V_{REF}$  must not be greater than  $0.6 \times V_{DDQ}$ . When  $V_{DD}$  and  $V_{DDQ}$  are less than 500mV,  $V_{REF}$  may be  $\leq 300mV$ .
  - The minimum limit requirement is for testing purposes. The leakage current on the  $V_{REF}$  pin should be minimal.
  - MAX operating case temperature.  $T_C$  is measured in the center of the package (see Figure 4 (page 9)).
  - Device functionality is not guaranteed if the DRAM device exceeds the maximum  $T_C$  during operation.

### Temperature and Thermal Impedance

It is imperative that the DDR3 SDRAM device's temperature specifications, shown in the following table, be maintained in order to ensure the junction temperature is in the proper operating range to meet data sheet specifications. An important step in maintaining the proper junction temperature is using the device's thermal impedances correctly. The thermal impedances listed in Table 6 (page 9) apply to the current die revision and packages.

Incorrectly using thermal impedances can produce significant errors. Read Micron technical note TN-00-08, "Thermal Applications," prior to using the values listed in the thermal impedance table. For designs that are expected to last several years and require the flexibility to use several DRAM die shrinks, consider using final target theta values (rather than existing values) to account for increased thermal impedances from the die size reduction.

The DDR3 SDRAM device's safe junction temperature range can be maintained when the  $T_C$  specification is not exceeded. In applications where the device's ambient temperature is too high, use of forced air and/or heat sinks may be required to satisfy the case temperature specifications.



## 16Gb: x4, x8 QuadDie DDR3 SDRAM Electrical Specifications – Absolute Ratings

**Table 5: Thermal Characteristics**

Notes 1–3 apply to entire table

Parameter	Symbol	Value	Units	Notes
Operating temperature	$T_C$	0 to 85	°C	
		0 to 95	°C	4

- Notes:
1. MAX operating case temperature  $T_C$  is measured in the center of the package, as shown below.
  2. A thermal solution must be designed to ensure that the device does not exceed the maximum  $T_C$  during operation.
  3. Device functionality is not guaranteed if the device exceeds maximum  $T_C$  during operation.
  4. If  $T_C$  exceeds 85°C, the DRAM must be refreshed externally at 2X refresh, which is a 3.9 $\mu$ s interval refresh rate. The use of self refresh temperature (SRT) or automatic self refresh (ASR), if available, must be enabled.

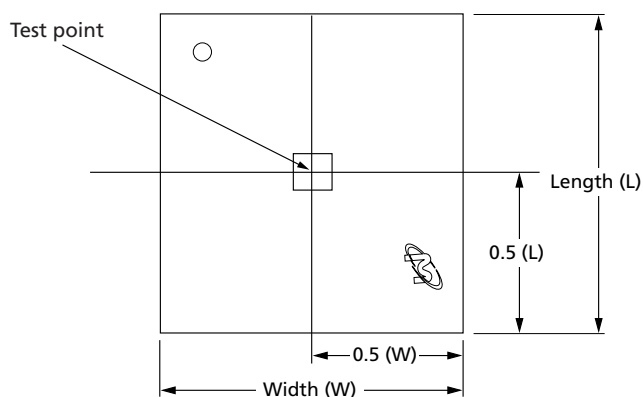
**Figure 4: Temperature Test Point Location**

**Table 6: Thermal Impedance**

Die Rev	Package	Substrate	$\Theta_{JA}$ (°C/W) Airflow = 0m/s	$\Theta_{JA}$ (°C/W) Airflow = 1m/s	$\Theta_{JA}$ (°C/W) Airflow = 2m/s	$\Theta_{JB}$ (°C/W)	$\Theta_{JC}$ (°C/W)	Notes
E	78-ball	2-layer	TBD	TBD	TBD	TBD	TBD	1
		4-layer	TBD	TBD	TBD	TBD		

- Note: 1. Thermal resistance data is based on a number of samples from multiple lots and should be viewed as a typical number.



## 16Gb: x4, x8 QuadDie DDR3 SDRAM Electrical Specifications – I<sub>CDD</sub> Parameters

### Electrical Specifications – I<sub>CDD</sub> Parameters

**Table 7: DDR3 I<sub>CDD</sub> Specifications and Conditions**

Notes: 1 applies to the entire table

Combined Symbol	Individual Die Status	Bus Width	-187E	Units
I <sub>CDD0</sub>	$I_{CDD0} = I_{DD0} + I_{DD2N} + I_{DD2P0} + I_{DD2P0} + 5$	x4, x8	113	mA
I <sub>CDD1</sub>	$I_{CDD1} = I_{DD1} + I_{DD2N} + I_{DD2P0} + I_{DD2P0} + 5$	x4	122	mA
		x8	128	
I <sub>CDD2P0</sub> (slow exit)	$I_{CDD2P0} = I_{DD2P0} + I_{DD2P0} + I_{DD2P0} + I_{DD2P0}$	x4, x8	72	mA
I <sub>CDD2P1</sub> (fast exit)	$I_{CDD2P1} = I_{DD2P1} + I_{DD2P0} + I_{DD2P0} + I_{DD2P0}$	x4, x8	80	mA
I <sub>CDD2Q</sub>	$I_{CDD2Q} = I_{DD2Q} + I_{DD2Q} + I_{DD2P0} + I_{DD2P0}$	x4, x8	90	mA
I <sub>CDD2N</sub>	$I_{CDD2N} = I_{DD2N} + I_{DD2N} + I_{DD2P0} + I_{DD2P0}$	x4, x8	92	mA
I <sub>CDD2NT</sub>	$I_{CDD2NT} = I_{DD2NT} + I_{DD2NT} + I_{DD2P0} + I_{DD2P0} + 5$	x4, x8	105	mA
I <sub>CDD3P</sub>	$I_{CDD3P} = I_{DD3P} + I_{DD2P0} + I_{DD2P0} + I_{DD2P0}$	x4, x8	86	mA
I <sub>CDD3N</sub>	$I_{CDD3N} = I_{DD3N} + I_{DD3N} + I_{DD2P0} + I_{DD2P0}$	All	199	mA
I <sub>CDD4R</sub>	$I_{CDD4R} = I_{DD4R} + I_{DD2N} + I_{DD2P0} + I_{DD2P0} + 5$	x4	182	mA
		x8	192	
I <sub>CDD4W</sub>	$I_{CDD4W} = I_{DD4W} + I_{DD2N} + I_{DD2P0} + I_{DD2P0} + 5$	x4	156	mA
		x8	164	
I <sub>CDD5B</sub>	$I_{CDD5B} = I_{DD5B} + I_{DD2N} + I_{DD2P0} + I_{DD2P0} + 5$	All	293	mA
I <sub>CDD6</sub>	$I_{CDD6} = I_{DD6} + I_{DD6} + I_{DD6} + I_{DD6}$	All	80	mA
I <sub>CDD6ET</sub>	$I_{CDD6ET} = I_{DD6ET} + I_{DD6ET} + I_{DD6ET} + I_{DD6ET}$	All	100	mA
I <sub>CDD7</sub>	$I_{CDD7} = I_{DD7} + I_{DD2N} + I_{DD2P0} + I_{DD2P0} + 5$	x4, x8	279	mA
I <sub>CDD8</sub>	$I_{CDD8} = 4 \times I_{DD2P0} + 8$	All	80	mA

Note: 1. I<sub>CDD</sub> values reflect the combined current of both individual die. I<sub>DDx</sub> represents individual die values.



# 16Gb: x4, x8 QuadDie DDR3 SDRAM Package Dimensions

## Package Dimensions

Figure 5: 78-Ball FBGA (package code SMA)

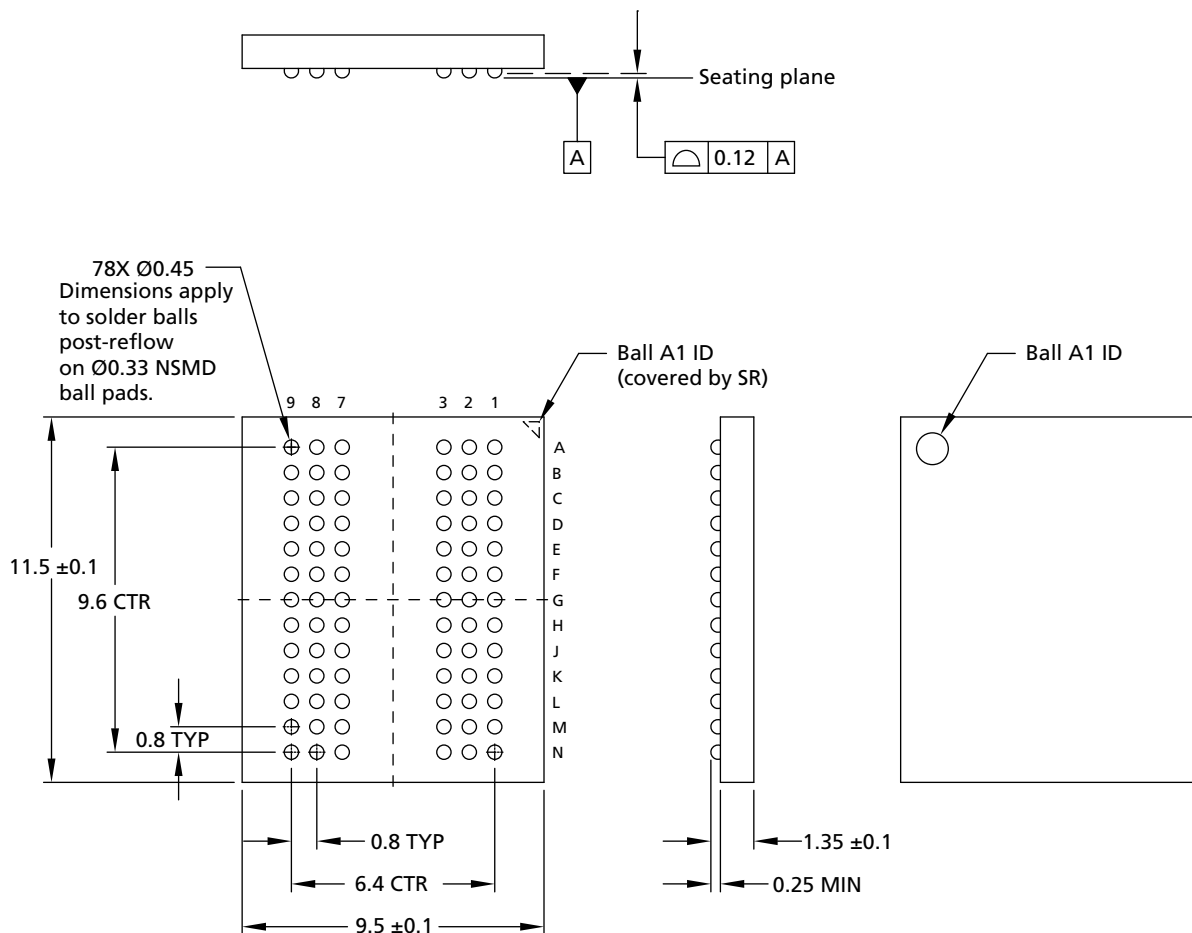

- Notes: 1. All dimensions are in millimeters.  
 2. Solder ball material: SAC305 (96.5% Sn, 3% Ag, 0.5% Cu).

8000 S. Federal Way, P.O. Box 6, Boise, ID 83707-0006, Tel: 208-368-3900  
 www.micron.com/productsupport Customer Comment Line: 800-932-4992  
 Micron and the Micron logo are trademarks of Micron Technology, Inc.  
 All other trademarks are the property of their respective owners.

This data sheet contains initial characterization limits that are subject to change upon full characterization of production devices.