

SL560

300MHz LOW NOISE AMPLIFIER

This monolithic circuit contains three very high performance transistors and associated biasing components in an eight-lead TO-5 package forming a 300MHz low noise amplifier. The configuration employed permits maximum flexibility with minimum use of external components. The SL560C is a general purpose low noise, high frequency gain block.

The device is also available as the SL560AC which has guaranteed operation over the fully Military Temperatures Range and is screened to MIL-STD-883 Class B. Data is available separately.

FEATURES

- Gain up to 40dB
- Noise Figures less than 2dB (Rs 200 ohm)
- Bandwidth 300MHz
- Supply Voltage 2-15V (Depending on Configuration)
- Low Power Consumption

APPLICATIONS

- Radar IF Preamplifiers
- Infra-Red Systems Head Amplifiers
- Amplifiers in Noise Measurement Systems
- Low Power Wideband Amplifiers
- Instrumentation Preamplifiers
- 50 ohm Line Drivers
- Wideband Power Amplifiers
- Wideband Dynamic Range IF Amplifiers
- Aerial Preamplifiers

ABSOLUTE MAXIMUM RATINGS

Supply voltage	+15V
Storage temperature	
SL560C DP	-55°C to +150°C
SL560C CM	-65°C to +150°C
Junction temperature	
SL560C DP	+150°C
SL560C CM	+175°C
Operating temperature range	
SL560C DP	-30°C to +85°C
SL560C CM	-55°C to +125°C
Thermal resistance	
Chip-to-ambient	
SL560C CM	225°C/W
SL560C DP	111°C/W
Chip-to-case	
SL560C CM	65°C/W
SL560C DP	71°C/W

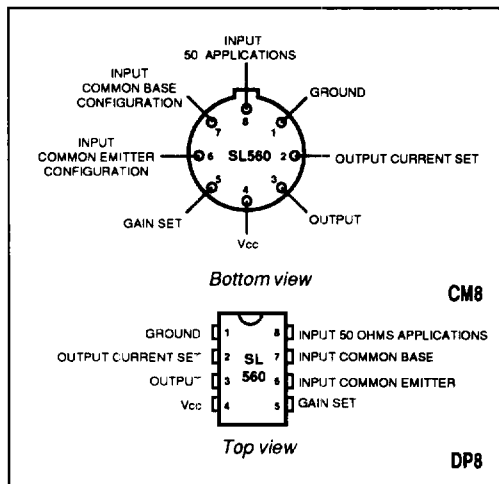

Fig. 1 Pin connections

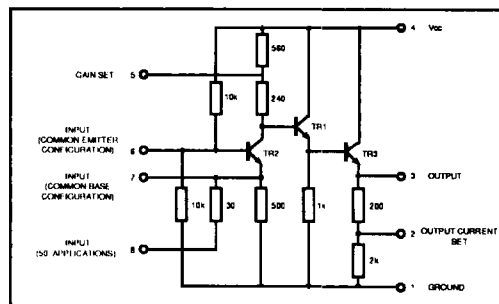

Fig. 2 SL560C circuit diagram

ORDERING INFORMATION

SL560 C CM
SL560 C DP
5962-90520 (SMD)

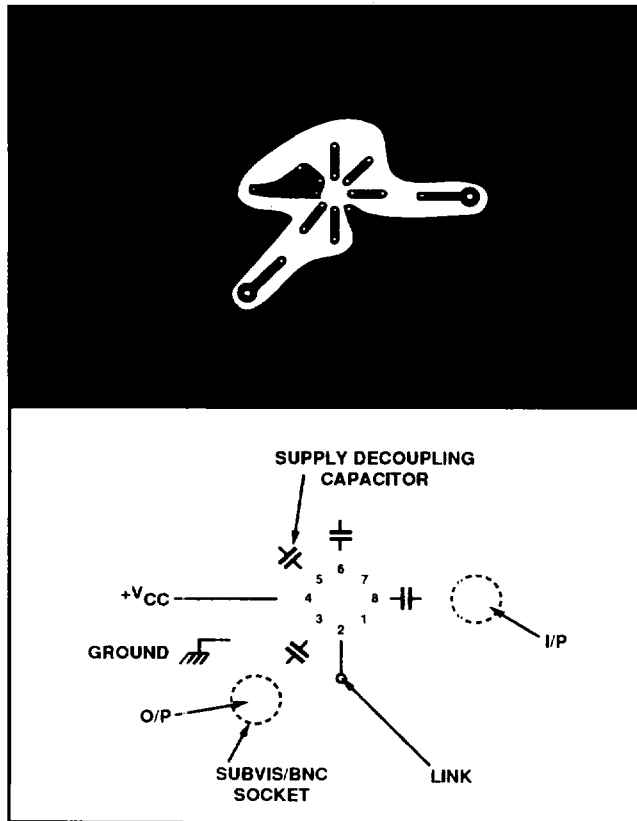

Fig 3 PC layout for 50Ω line driver (see Fig.6)

SL560

ELECTRICAL CHARACTERISTICS

These characteristics are guaranteed over the following conditions (unless otherwise stated)

Frequency = 30MHz; $V_{CC}=6V$; $R_S = R_L = 50\Omega$; $T_{AMB}=22^\circ C \pm 2^\circ C$; Test Circuit: Fig.6

Characteristic	Min.	Typ.	Max.	Units	Conditions
Small signal voltage gain	11	14	17	dB	10MHz - 220MHz $V_{CC}=6V$ $V_{CC} = 9V$ $R_S = 200\Omega$ $R_S = 50\Omega$
Gain flatness		± 1.5		dB	
Upper cut-off frequency		250		MHz	
Output swing	+5	+7		dBm	
		+11		dBm	
Noise figure (common emitter)		1.8		dB	
		3.5		dB	
Supply current		20	30	mA	

CIRCUIT DESCRIPTION

Three high performance transistors of identical geometry are employed. Advanced design and processing techniques enable these devices to combine a low base resistance (R_{bb}) of 17Ω (for low noise operation) with a small physical size - giving a transition frequency, f_T , in excess of 1GHz.

The input transistor (TR1) is normally operating in common base, giving a well defined low input impedance. The full voltage gain is produced by this transistor and the output voltage produced at its collector buffered by the two emitter followers (TR2 and TR3). To obtain maximum bandwidth the capacitance at the collector of TR1 must be minimised. Hence, to avoid bonding pad and can capacitances, this point is not brought out of the package. The collector load resistance of TR1 is split, the tapping being accessible via pin 5. If required, an external roll-off capacitor can be fixed to this point.

The large number of circuit nodes accessible from the outside of the packages affords great flexibility, enabling the operating current and circuit configuration to be optimised for any application. In particular, the input transistor (TR1) can be operated in common emitter mode by decoupling pin 7 and using 6 as the input. In this configuration, a 2dB noise figure ($R_S = 200\Omega$) can be achieved. This configuration can give a gain of 35dB with a bandwidth of 300MHz (see figs. 10 and 11).

Because the transistors used in the SL560C exhibit a high value of f_T , care must be taken to avoid high frequency instability. Capacitors of small physical size should be used, the leads of which must be short as possible to avoid oscillation brought about by stray inductance. The use of a ground plane is recommended.

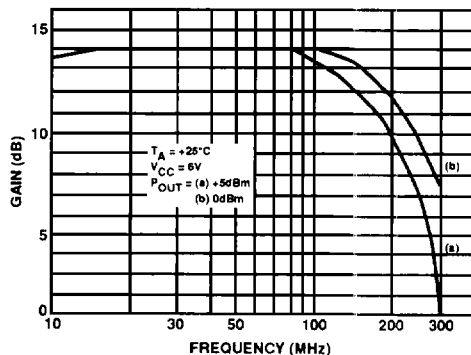

Fig.4 Frequency response, small signal gain is of a typical device

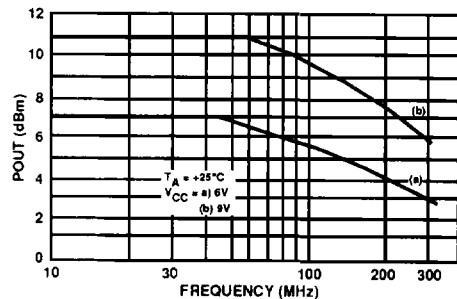

Fig.5. Frequency response, output capability (loci of maximum output power with frequency for 1dB gain compression (typical))

TYPICAL APPLICATIONS

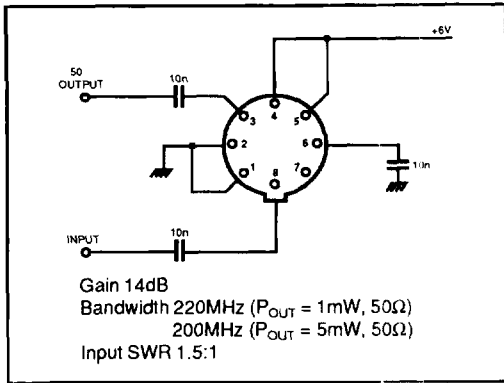

Fig.6 50Ω lin driver. The response of this configuration is shown in Fig.4

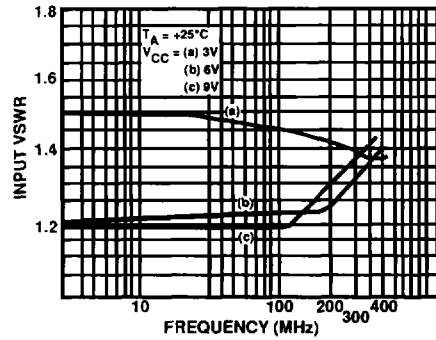

Fig.7 Input standing wave ratio plot of circuit shown in Fig.6 (typical)

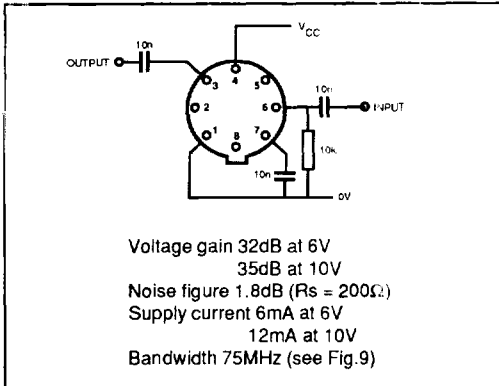

Fig.8 Low Noise preamplifier

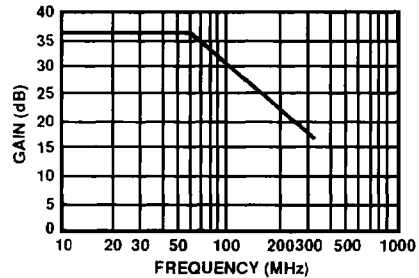

Fig.9 Frequency response of circuit shown in Fig.8 (typical)

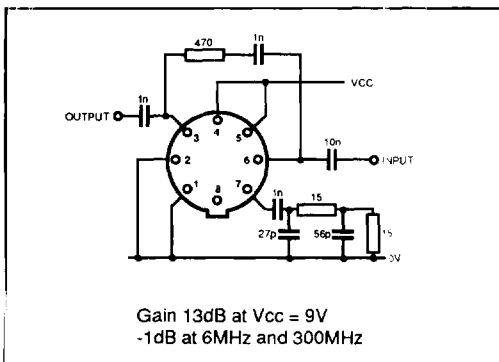

Fig.10 Wide bandwidth amplifier

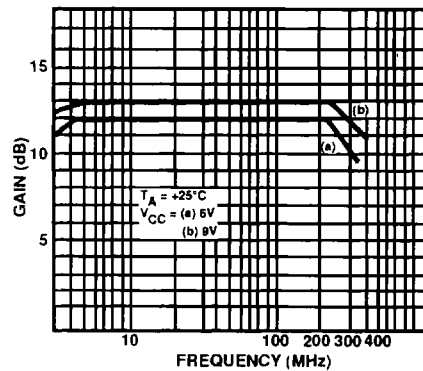

Fig.11 Frequency response of circuit shown in Fig.10 (typical)

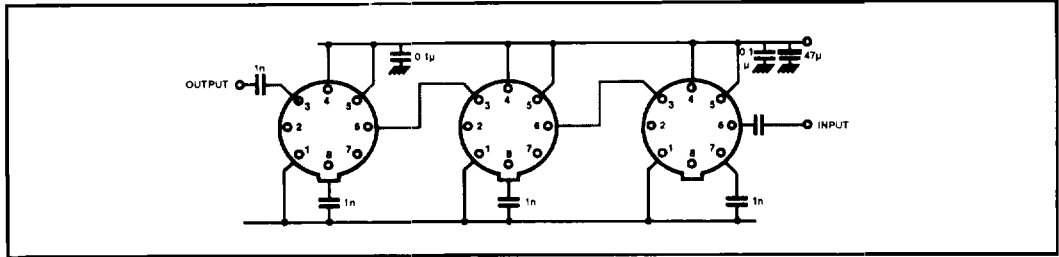

Fig.12 Three-stage directly-coupled high gain low noise amplifier

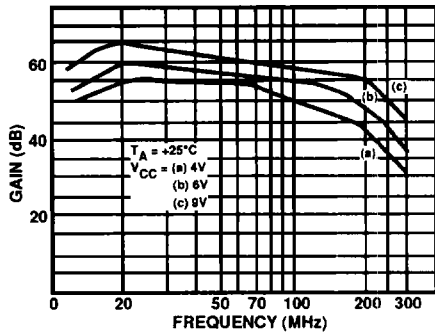

Fig.13 Frequency response of circuit shown in Fig.12 (typical)

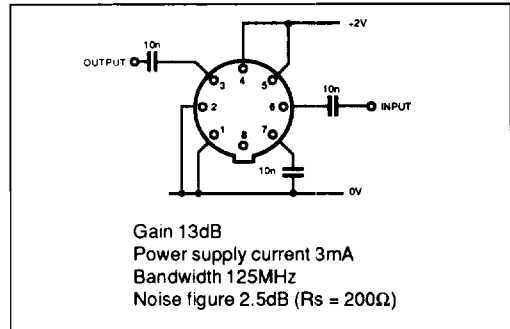

Fig.14 Low power consumption amplifier

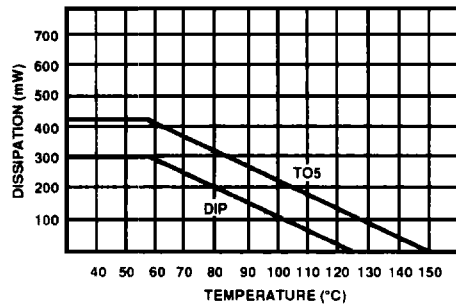

Fig.15 Ambient operating temperature $V.$ degrees centigrade (typical)