

# SMD Power Inductor

## CDRH2D18/HP



### Description

- Ferrite drum core construction
- Magnetically shielded
- LxWxH:3.2x3.2x2.0 mm Max.
- Product weight: 65mg (Ref.)
- Moisture Sensitivity Level: 1
- RoHS compliance

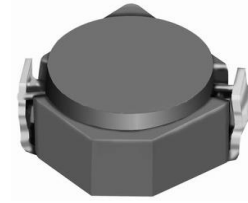

### Environmental Data

- Operating temperature range: -40°C~+105°C (including coil's self temperature rise)
- Storage temperature range: -40°C~+105°C
- Solder reflow temperature: 260 °C peak

### Packaging

- Carrier tape and reel packaging
- 7.0" diameter reel, 1000pcs per reel

### Applications

- Ideally used in mobile phone, PDA, MP3, DSC/DVC, etc. as DC-DC converter inductors

### Dimension - [mm]

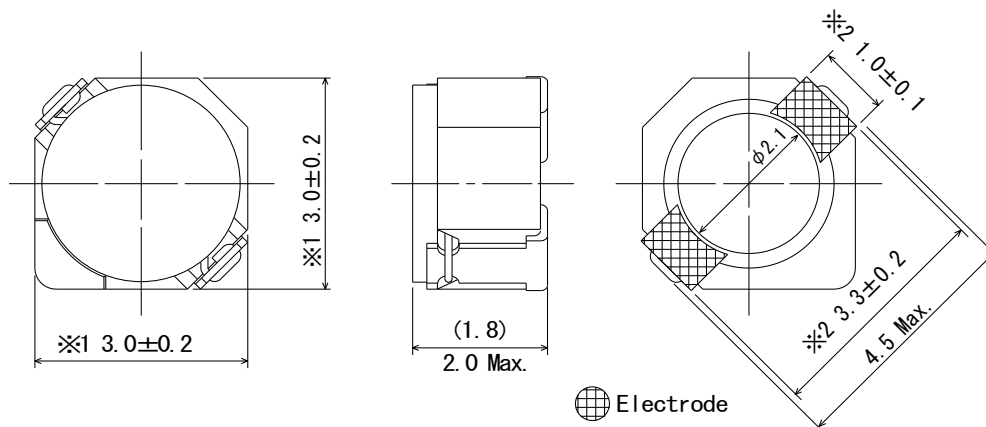

※1 Not including terminal dimension.

※2 Electrode dimension

Note: This specification is subject to change without notice. Please contact your nearest sales office for updated information when placing an order.

# SMD Power Inductor

## CDRH2D18/HP



### Reference Land pattern – [mm]

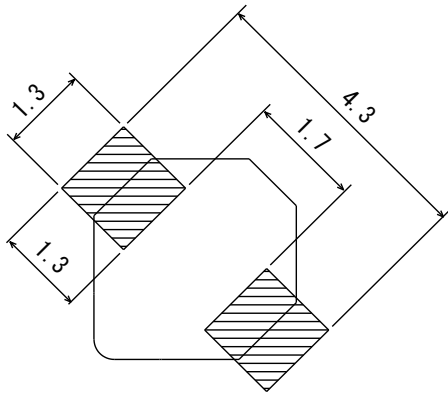

### Connection

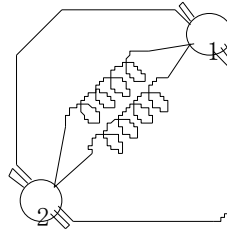

(0.20µH ~ 3.3µH)

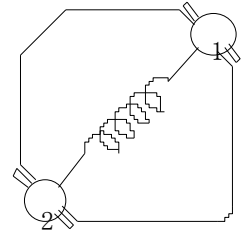

(4.7µH ~ 15µH)

Note: This specification is subject to change without notice. Please contact your nearest sales office for updated information when placing an order.

# SMD Power Inductor

## CDRH2D18/HP



### Electrical Characteristics

Part No.	Stamp	Inductance [within] ( $\mu$ H) ※1	D.C.R. [Within] (m $\Omega$ ) (at 20°C) Max. (Typ.)	Saturation Current (A) Max. (Typ.) ※2		Temperature Rise Current (A) Max. (Typ.) ※3
				at 20°C	at 100°C	
CDRH2D18/HPNP-R20NC	N	0.20 $\pm$ 35%	22 (17)	5.35	3.55	(4.70)
CDRH2D18/HPNP-R36NC	P	0.36 $\pm$ 35%	29 (22)	4.62	3.00	(4.10)
CDRH2D18/HPNP-R56NC	Q	0.56 $\pm$ 35%	33 (25)	3.75	2.76	(3.60)
CDRH2D18/HPNP-R82NC	R	0.82 $\pm$ 35%	39 (30)	2.91	2.20	(3.30)
CDRH2D18/HPNP-1R1NC	S	1.10 $\pm$ 35%	43 (33)	2.50	1.90	(2.90)
CDRH2D18/HPNP-1R7NC	A	1.70 $\pm$ 30%	44 (35)	1.85	1.36	(2.20)
CDRH2D18/HPNP-2R2NC	C	2.20 $\pm$ 30%	60 (48)	1.60	1.15	(1.90)
CDRH2D18/HPNP-3R3NC	E	3.30 $\pm$ 30%	86 (69)	1.45	1.10	(1.55)
CDRH2D18/HPNP-4R7NC	G	4.70 $\pm$ 30%	140 (110)	1.20	0.90	(1.20)
CDRH2D18/HPNP-6R3NC	I	6.30 $\pm$ 30%	160 (128)	1.05	0.78	(1.15)
CDRH2D18/HPNP-100NC	K	10.0 $\pm$ 30%	245 (195)	0.85	0.65	(0.90)
CDRH2D18/HPNP-150NC	M	15.0 $\pm$ 30%	345 (275)	0.70	0.53	(0.64)

※1 Inductance measuring condition: 0.20  $\mu$  H~1.10  $\mu$  H at 7.96MHz; 1.70  $\mu$  H~15.0  $\mu$  H at 100kHz

※2 Saturation current: The value of D.C. current when the inductance decreases to 65% of its nominal value.

※3 Temperature rise current: The value of D.C. current when the temperature rise is  $\Delta t=40^{\circ}\text{C}$ ( $T_a=20^{\circ}\text{C}$ ).

### Solder Reflow Condition

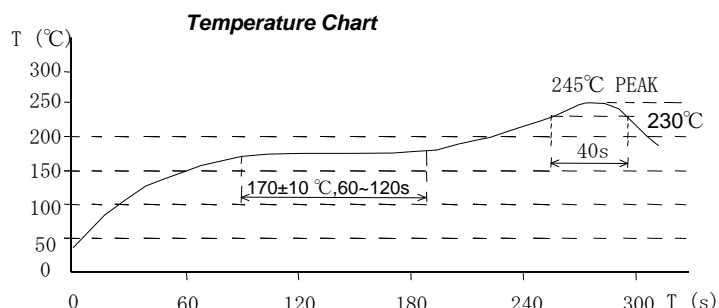
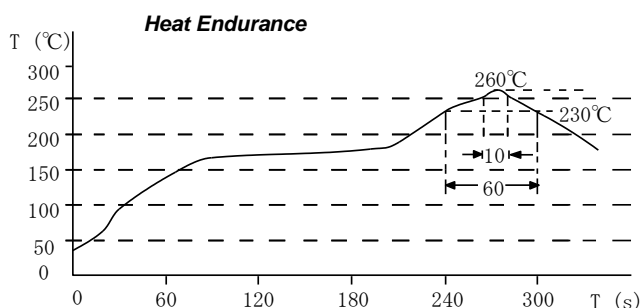

Note: This specification is subject to change without notice. Please contact your nearest sales office for updated information when placing an order.

# SMD Power Inductor

## CDRH2D18/HP



Saturation Current & Temperature Rise Graph — L (20°C) — L (100°C) —  $\Delta T$

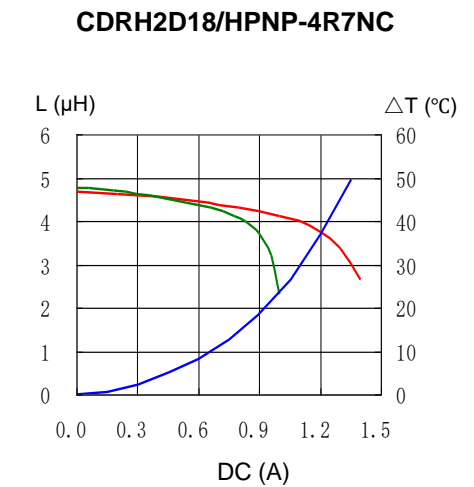
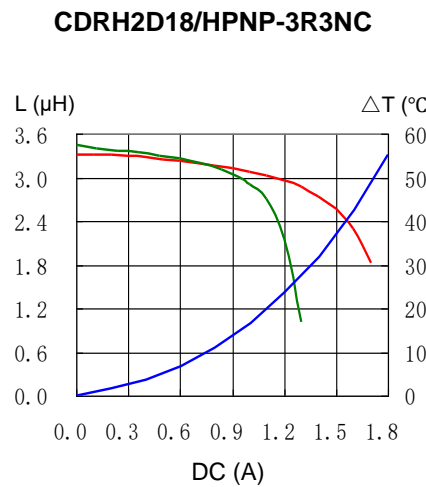
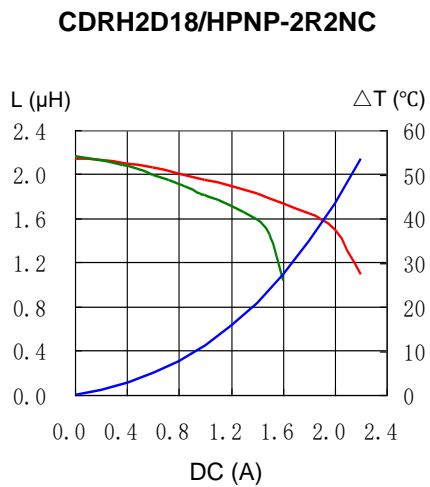
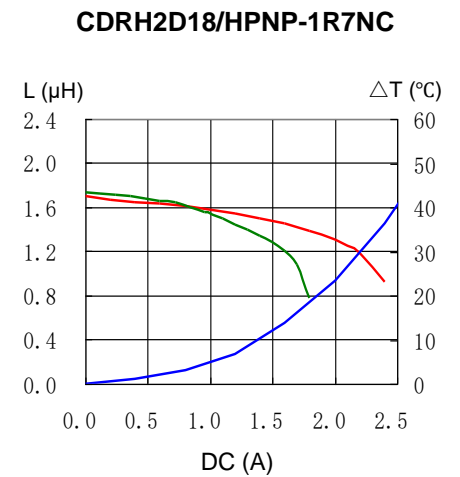
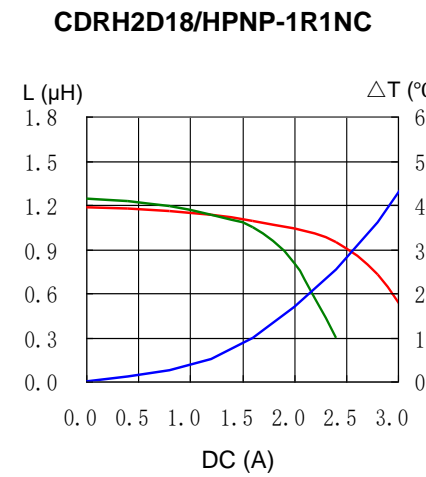
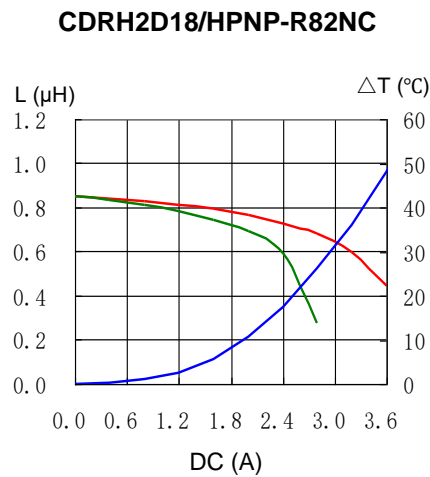
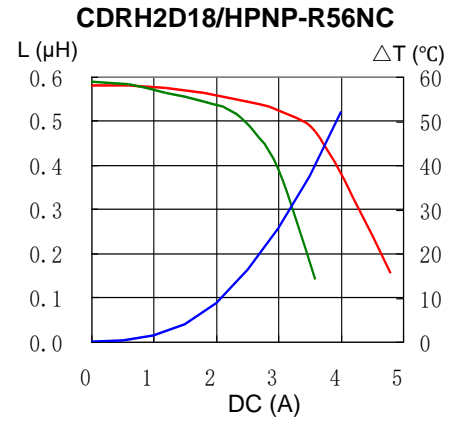
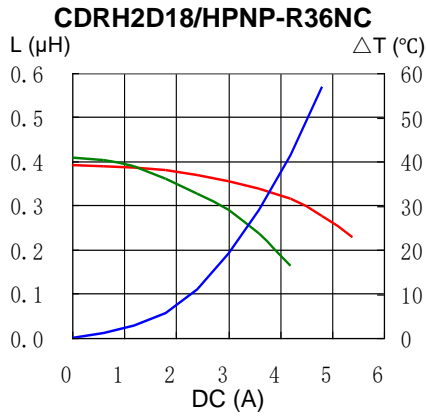
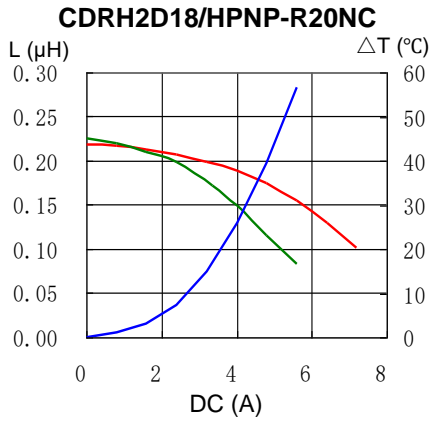

Note: This specification is subject to change without notice. Please contact your nearest sales office for updated information when placing an order.

# SMD Power Inductor

## CDRH2D18/HP



Saturation Current & Temperature Rise Graph — L (20°C) — L (100°C) —  $\Delta T$

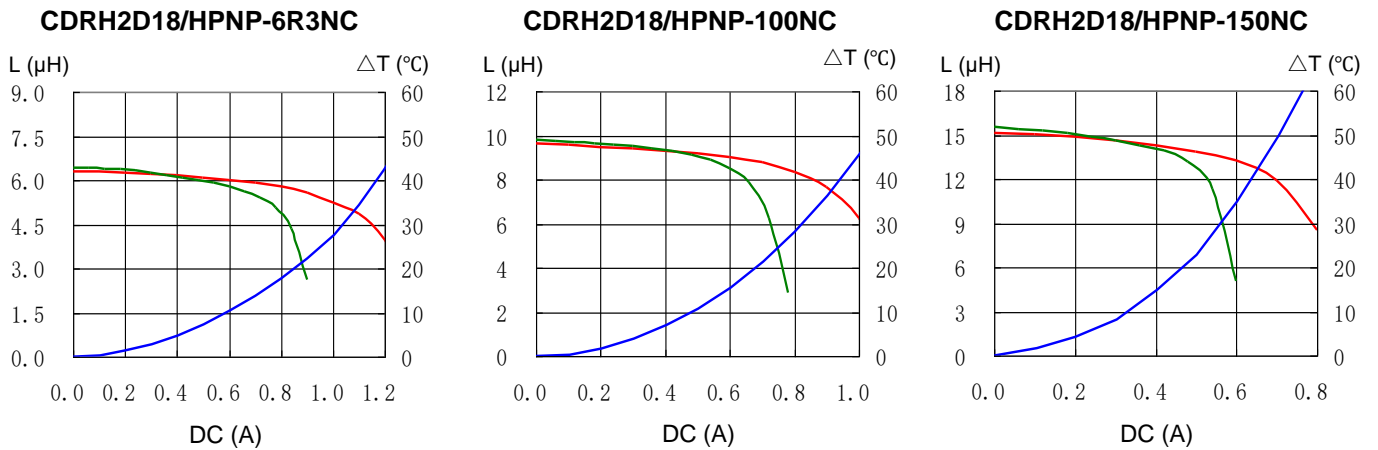

For sales office information, please [click here](#) to visit our website.

Note: This specification is subject to change without notice. Please contact your nearest sales office for updated information when placing an order.