

Dual 1.5A Adjustable Positive Voltage Regulators

VRG8607/08

Features

- Manufactured using Linear Technology Corporation ® Space Qualified RH117 die
- Radiation performance
 - Total dose: 100 krad(Si), Dose rate = 50-300 rad(Si)/s
 - ELDRS: 50 krad(Si), Dose rate \leq 10 mrad(Si)/s
- Thermal shutdown
- Output voltage adjustable: 1.25V to 37V
- 3-Terminal
- Output current: 1.5A
- Voltage reference: 1.25V
- Load regulation: 1.9% max
- Line regulation: 0.06%/V max
- Ripple rejection: >66dB
- Packaging – Hermetic metal
 - Thru-hole or Surface mount
 - 6 Leads, .655"L x .415"W x .200"Ht
 - Power package
 - Weight - 5 gm max
- Designed for aerospace and high reliability space applications
- **Radiation Hardness Assurance Plan: DLA Certified to MIL-PRF-38534, Appendix G.**

Description

The VRG8607/08 consists of two positive (RH117) voltage regulators each capable of supplying in excess of 1.5Amps over the output voltage range as defined under recommended operating conditions. Each regulator is exceptionally easy to set-up, requiring only 2 external resistors to set the output voltage. The module design has been optimized for excellent regulation and low thermal transients. There is full electrical isolation between the regulators and each regulator to the package.

Further, the VRG8607/08 features internal current limiting, thermal shutdown and safe-area compensation, making them virtually blowout-proof against overloads. The VRG8607/08 serves a wide variety of applications including local on-card regulation, programmable output voltage regulation or precision current regulation.

The VRG8607/08 has been specifically designed to meet exposure to radiation environments. The VRG8607 is configured for a Thru-Hole 6 lead metal power package and the VRG8608 is configured for a Surface Mount 6 lead metal power package. It is guaranteed operational from -55°C to +125°C. Available screened to MIL-STD-883, the VRG8607/08 is ideal for demanding military and space applications.

For detailed performance characteristic curves, applications information and typical applications see the latest Linear Technology Corporation ® data sheets for their RH/LT117.

VRG8607/08

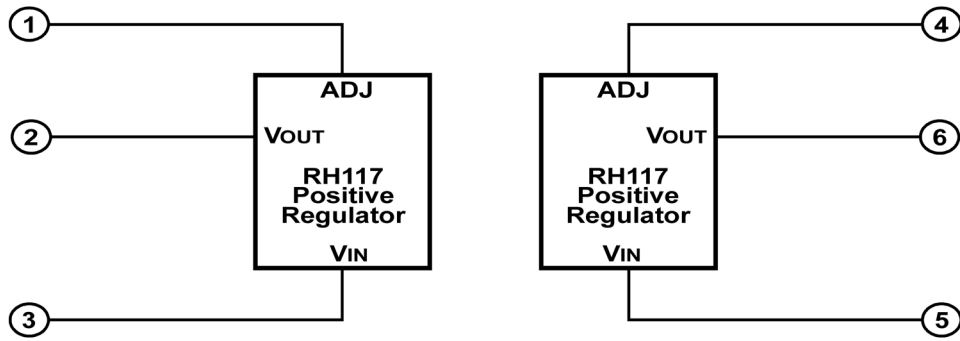

Figure 1- Block Diagram / Schematic

Absolute Maximum Ratings

Parameter	Range	Units
Operating (Junction) Temperature Range	-55 to +150	°C
Lead Temperature (soldering, 10 sec)	300	°C
Storage Temperature Range	-65 to +150	°C
Input-Output Voltage Differential	40 (Pos)	V
Thermal Resistance (Junction to case θ_{JC}) each Regulator	5	°C/W
ESD Rating	1.999 ^{1/}	KV

^{1/}Meets ESD testing per MIL-STD-883, method 3015, Class 1C.

Notice: Stresses above those listed under "Absolute Maximum Ratings" may cause permanent damage to the device. These are stress rating only; functional operation beyond the "Operation Conditions" is not recommended and extended exposure beyond the "Operation Conditions" may affect device reliability.

Recommended Operating Conditions

Parameter	Range	Units
Output Voltage Range	1.3 to 37	V _{DC}
Case Operating Temperature Range	-55 to +125	°C

VRG8607/08

Electrical Performance Characteristics 1/

Parameter	SYM	Conditions ($P \leq P_{max}$)	MIN	MAX	Units
Reference Voltage 4/	V_{REF}	$3V \leq (V_{IN} - V_{OUT}) \leq V_{DIFF MAX}$, $10mA \leq I_{OUT} \leq I_{MAX}$	1.200	1.300	V
Line Regulation 2/ 4/	$\frac{\Delta V_{OUT}}{\Delta V_{IN}}$	$3V \leq (V_{IN} - V_{OUT}) \leq V_{DIFF MAX}$, $I_{OUT} = 10mA$	-	0.03	%/V
Load Regulation 2/ 4/	$\frac{\Delta V_{OUT}}{\Delta I_{OUT}}$	$10mA \leq I_{OUT} \leq I_{MAX}$, $V_{OUT} \leq 5V$ $10mA \leq I_{OUT} \leq I_{MAX}$, $V_{OUT} \geq 5V$	-	60 1.2	mV %
Thermal Regulation		$I_{OUT} = 1.5A$, $(V_{IN} - V_{OUT}) = 13.3V$, 20ms Pulse, 20W, $T_C = +25^\circ C$	-	0.07	%/W
Ripple Rejection Ratio		$V_{OUT} = 10V$, $f = 120Hz$, $C_{ADJ} = 10\mu F$	66	-	dB
Adjustment Pin Current 4/	I_{ADJ}	$I_{OUT} = 10mA$, $3V \leq (V_{IN} - V_{OUT}) \leq 40V$	-	100	μA
Adjustment Pin Current Change 4/	ΔI_{ADJ}	$10mA \leq I_{OUT} \leq I_{MAX}$ $3.0V \leq (V_{IN} - V_{OUT}) \leq 40V$	-	5	μA
Minimum Load Current 3/ 4/	I_{MIN}	$(V_{IN} - V_{OUT}) = 40V$	-	5	mA
Current Limit 4/ 5/	I_{MAX}	$(V_{IN} - V_{OUT}) \leq 15V$	1.5	-	A
		$(V_{IN} - V_{OUT}) = 40V$, $T_C = +25^\circ C$	0.30	-	
Long Term Stability 3/	$\frac{\Delta V_{OUT}}{\Delta T_{IME}}$	$T_C = +125^\circ C$	-	1	%
Thermal Resistance, each Regulator (Junction to Case) 3/	Θ_{JC}		-	5	$^\circ C/W$

Notes:

- 1) Unless otherwise specified, these specifications apply for $(V_{in} - V_{out}) = 5V$, $I_{out} = 0.5A$ and $-55^\circ C < T_C < +125^\circ C$.
- 2) Regulation is measured at a constant junction temperature, using pulse testing with a low duty cycle. Changes in output voltage due to heating effects are covered under the specification for thermal regulation. Measurements taken at the output lead must be adjusted for lead resistance.
- 3) Not tested. Shall be guaranteed to the specified limits.
- 4) Specification derated to reflect High Dose Rate (1019 condition A) to 100 krad(Si) and Low Dose Rate (1019 condition D) to 50 krad(Si), @ $+25^\circ C$.
- 5) Pulsed @ $< 10\%$ duty cycle @ $+25^\circ C$.

VRG8607/08

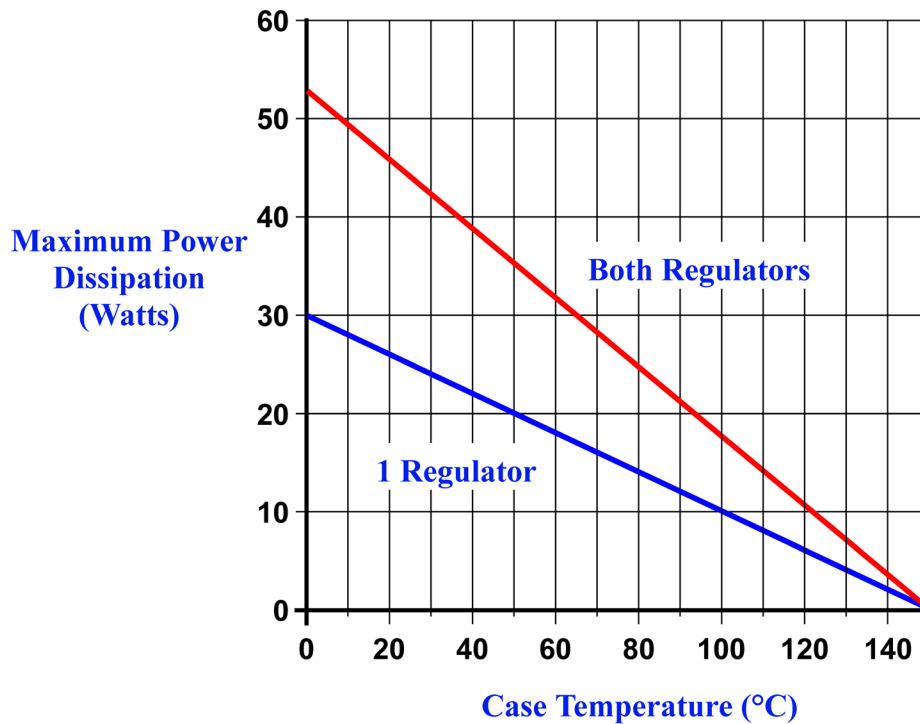
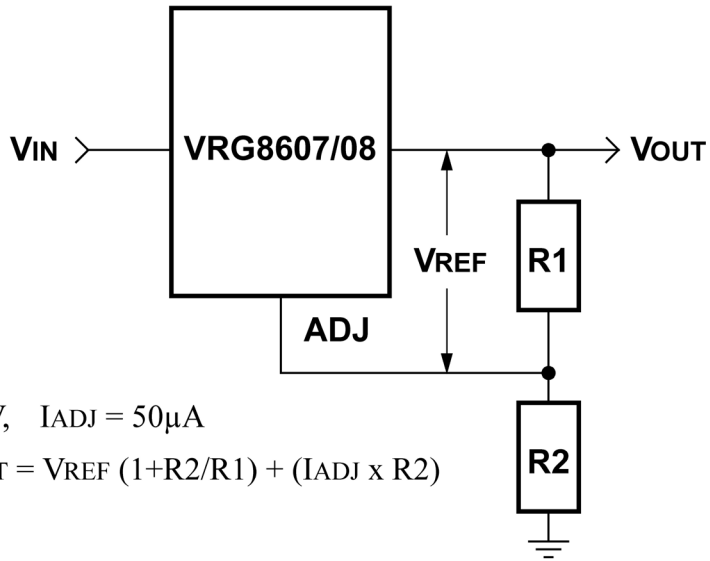

Figure 2- Maximum Power vs Case Temperature

The maximum Power dissipation is limited by the thermal shutdown function of each regulator chip in the VRG8607/08. The graph above represents the achievable power before the chip shuts down. The first line in the graph represents the maximum power dissipation of the VRG8607/08 with one regulator on (the other off) and the other line represents both regulators on dissipating equal power. If both regulators are on and one regulator is dissipating more power than the other, the maximum power dissipation of the VRG8607/08 will fall between the two lines. This graph is based on the maximum junction temperature of 150°C and a thermal resistance (Θ_{JC}) of 5°C/W.

VRG8607/08



$V_{REF} = 1.25V, \quad I_{ADJ} = 50\mu A$
 $+Reg = V_{OUT} = V_{REF} (1 + R2/R1) + (I_{ADJ} \times R2)$

Adjustable Regulator
Figure 3- Typical Applications

Table I – Pin Numbers vs Function

Pin	Function
1	POS_ADJ_1
2	POS_VOUT_1
3	POS_VIN_1
4	POS_ADJ_2
5	POS_VIN_2
6	POS_VOUT_2

VRG8607/08

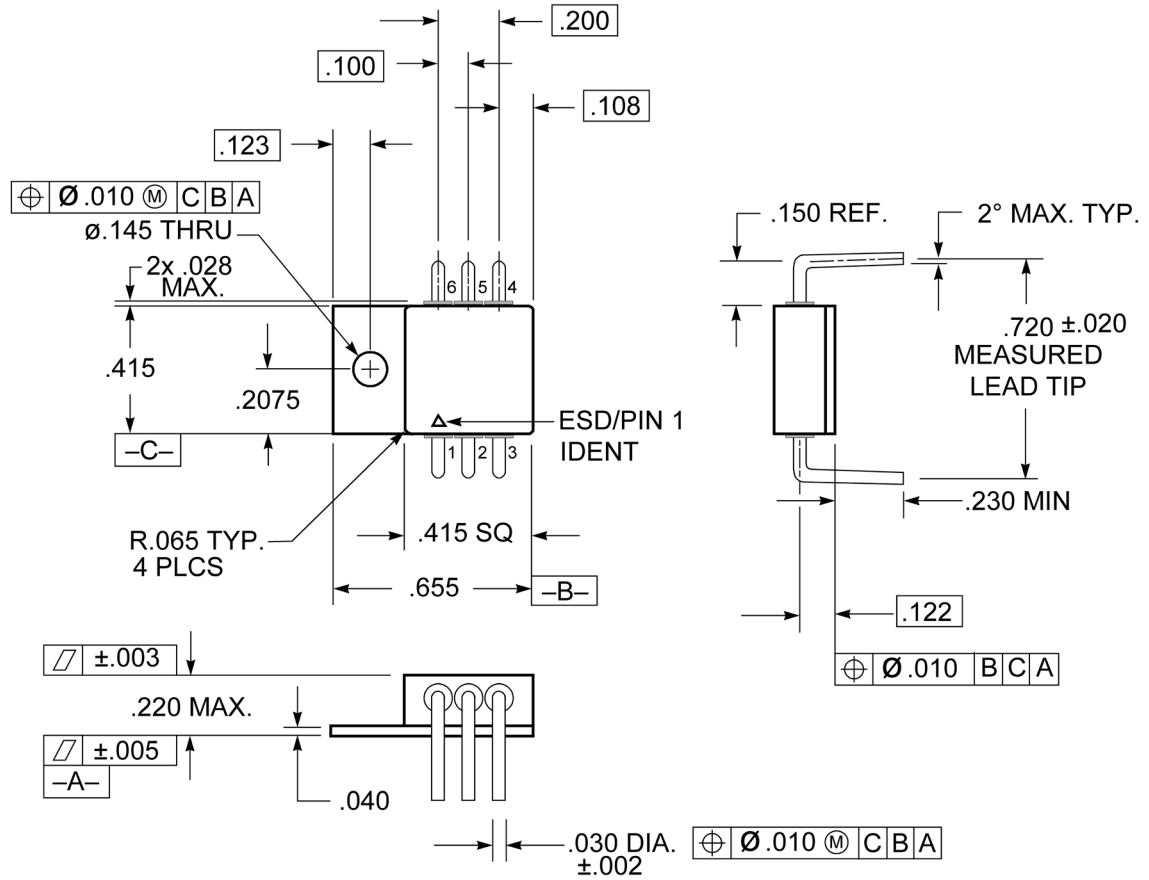

Figure 4: Package Outline — Thru-Hole Power Package

Notes:

- 1) Dimension Tolerance: $\pm .005$ inches
- 2) Package contains BeO substrate
- 3) Case electrically isolated

Table II – Pin Numbers vs Function

Pin	Function
1	POS_ADJ_1
2	POS_V _{OUT} _1
3	POS_V _{IN} _1
4	POS_ADJ_2
5	POS_V _{IN} _2
6	POS_V _{OUT} _2

Dual 1.5A Adjustable Positive Voltage Regulators

VRG8607/08

Ordering Information

Model	DLA SMD #	Screening	Package
VRG8607 - 7	-	Commercial Flow, +25°C testing only	6 Lead Thru-Hole Power Pkg
VRG8607 - S	-	Military Temperature, -55°C to +125°C Screened in accordance with the individual Test Methods of MIL-STD-883 for Space Applications	
VRG8607- 201-1S	5962-0521903KXC	In accordance with DLA SMD	
VRG8607- 201-2S	5962-0521903KXA		
VRG8607- 901-1S	5962R0521903KXC	In accordance with DLA Certified RHA Program Plan to RHA level "R", 100 krad(Si)	
VRG8607- 901-2S	5962R0521903KXA		
VRG8608 - 7	-	Commercial Flow, +25°C testing only	6 Lead Surface Mount Power Pkg
VRG8608 - S	-	Military Temperature, -55°C to +125°C Screened in accordance with the individual Test Methods of MIL-STD-883 for Space Applications	
VRG8608- 201-1S	5962-0521903KYC	In accordance with DLA SMD	
VRG8608- 201-2S	5962-0521903KYA		
VRG8608- 901-1S	5962R0521903KYC	In accordance with DLA Certified RHA Program Plan to RHA level "R", 100 krad(Si)	
VRG8608- 901-2S	5962R0521903KYA		

Revision History

Date	Revision	Change Description
3/24/2016	F	Import into CAES format



VRG8607/08

Datasheet Definitions

	DEFINITION
Advanced Datasheet	CAES reserves the right to make changes to any products and services described herein at any time without notice. The product is still in the development stage and the datasheet is subject to change . Specifications can be TBD and the part package and pinout are not final .
Preliminary Datasheet	CAES reserves the right to make changes to any products and services described herein at any time without notice. The product is in the characterization stage and prototypes are available.
Datasheet	Product is in production and any changes to the product and services described herein will follow a formal customer notification process for form, fit or function changes.

The following United States (U.S.) Department of Commerce statement shall be applicable if these commodities, technology, or software are exported from the U.S.: These commodities, technology, or software were exported from the United States in accordance with the Export Administration Regulations. Diversion contrary to U.S. law is prohibited.

Cobham Long Island Inc. d/b/a Cobham Advanced Electronic Solutions (CAES) reserves the right to make changes to any products and services described herein at any time without notice. Consult an authorized sales representative to verify that the information in this data sheet is current before using this product. The company does not assume any responsibility or liability arising out of the application or use of any product or service described herein, except as expressly agreed to in writing; nor does the purchase, lease, or use of a product or service convey a license under any patent rights, copyrights, trademark rights, or any other of the intellectual rights of the company or of third parties.