

# SN54LVT646, SN74LVT646

## 3.3-V ABT OCTAL BUS TRANSCIEVERS AND REGISTERS WITH 3-STATE OUTPUTS

SCBS140D - MAY 1992 - REVISED JULY 1995

- State-of-the-Art Advanced BICMOS Technology (ABT) Design for 3.3-V Operation and Low Static Power Dissipation
- Support Mixed-Mode Signal Operation (5-V Input and Output Voltages With 3.3-V  $V_{CC}$ )
- Support Unregulated Battery Operation Down to 2.7 V
- Typical  $V_{OLP}$  (Output Ground Bounce) < 0.8 V at  $V_{CC} = 3.3$  V,  $T_A = 25^\circ\text{C}$
- ESD Protection Exceeds 2000 V Per MIL-STD-883C, Method 3015; Exceeds 200 V Using Machine Model ( $C = 200$  pF,  $R = 0$ )
- Latch-Up Performance Exceeds 500 mA Per JEDEC Standard JESD-17
- Bus-Hold Data Inputs Eliminate the Need for External Pullup Resistors
- Support Live Insertion
- Package Options Include Plastic Small-Outline (DW), Shrink Small-Outline (DB), and Thin Shrink Small-Outline (PW) Packages, Ceramic Chip Carriers (FK), Ceramic Flat (W) Packages, and Ceramic (JT) DIPs

### description

These bus transceivers and registers are designed specifically for low-voltage (3.3-V)  $V_{CC}$  operation, but with the capability to provide a TTL interface to a 5-V system environment.

The 'LVT646 consist of bus transceiver circuits, D-type flip-flops, and control circuitry arranged for multiplexed transmission of data directly from the input bus or from the internal registers. Data on the A or B bus is clocked into the registers on the low-to-high transition of the appropriate clock (CLKAB or CLKBA) input. Figure 1 illustrates the four fundamental bus-management functions that can be performed with the 'LVT646.

Output-enable ( $\overline{OE}$ ) and direction-control (DIR) inputs are provided to control the transceiver functions. In the transceiver mode, data present at the high-impedance port may be stored in either register or in both.

The select-control (SAB and SBA) inputs can multiplex stored and real-time (transparent mode) data. The direction control (DIR) determines which bus receives data when  $\overline{OE}$  is low. In the isolation mode ( $\overline{OE}$  high), A data may be stored in one register and/or B data may be stored in the other register.

When an output function is disabled, the input function is still enabled and may be used to store and transmit data. Only one of the two buses, A or B, may be driven at a time.

SN54LVT646 ... JT OR W PACKAGE  
SN74LVT646 ... DB, DW, OR PW PACKAGE  
(TOP VIEW)

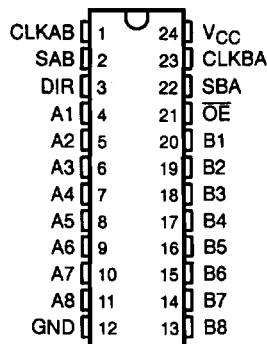

SN54LVT646 ... FK PACKAGE  
(TOP VIEW)

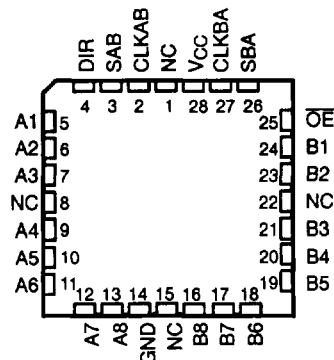

NC - No internal connection

PRODUCTION DATA Information is current as of publication date. Products conform to specifications per the terms of Texas Instruments standard warranty. Production processing does not necessarily include testing of all parameters.



**SN54LVT646, SN74LVT646**  
**3.3-V ABT OCTAL BUS TRANSCEIVERS AND REGISTERS**  
**WITH 3-STATE OUTPUTS**

SCBS140D – MAY 1992 – REVISED JULY 1995

**description (continued)**

Active bus-hold circuitry is provided to hold unused or floating data inputs at a valid logic level.

To ensure the high-impedance state during power up or power down,  $\overline{OE}$  should be tied to  $V_{CC}$  through a pullup resistor; the minimum value of the resistor is determined by the current-sinking capability of the driver.

The SN74LVT646 is available in TI's shrink small-outline package (DB), which provides the same I/O pin count and functionality of standard small-outline packages in less than half the printed-circuit-board area.

The SN54LVT646 is characterized for operation over the full military temperature range of  $-55^{\circ}\text{C}$  to  $125^{\circ}\text{C}$ . The SN74LVT646 is characterized for operation from  $-40^{\circ}\text{C}$  to  $85^{\circ}\text{C}$ .

**FUNCTION TABLE**

INPUTS						DATA I/Os		OPERATION OR FUNCTION
$\overline{OE}$	DIR	CLKAB	CLKBA	SAB	SBA	A1–A8	B1–B8	
X	X	↑	X	X	X	Input	Unspecified†	Store A, B unspecified†
X	X	X	↑	X	X	Unspecified†	Input	Store B, A unspecified†
H	X	↑	↑	X	X	Input	Input	Store A and B data
H	X	H or L	H or L	X	X	Input disabled	Input disabled	Isolation, hold storage
L	L	X	X	X	L	Output	Input	Real-time B data to A bus
L	L	X	H or L	X	H	Output	Input	Stored B data to A bus
L	H	X	X	L	X	Input	Output	Real-time A data to B bus
L	H	H or L	X	H	X	Input	Output	Stored A data to B bus

† The data output functions may be enabled or disabled by various signals at the  $\overline{OE}$  and DIR inputs. Data input functions are always enabled; i.e., data at the bus pins is stored on every low-to-high transition of the clock inputs.



# SN54LVT646, SN74LVT646 3.3-V ABT OCTAL BUS TRANSCEIVERS AND REGISTERS WITH 3-STATE OUTPUTS

SCBS140D – MAY 1992 – REVISED JULY 1995

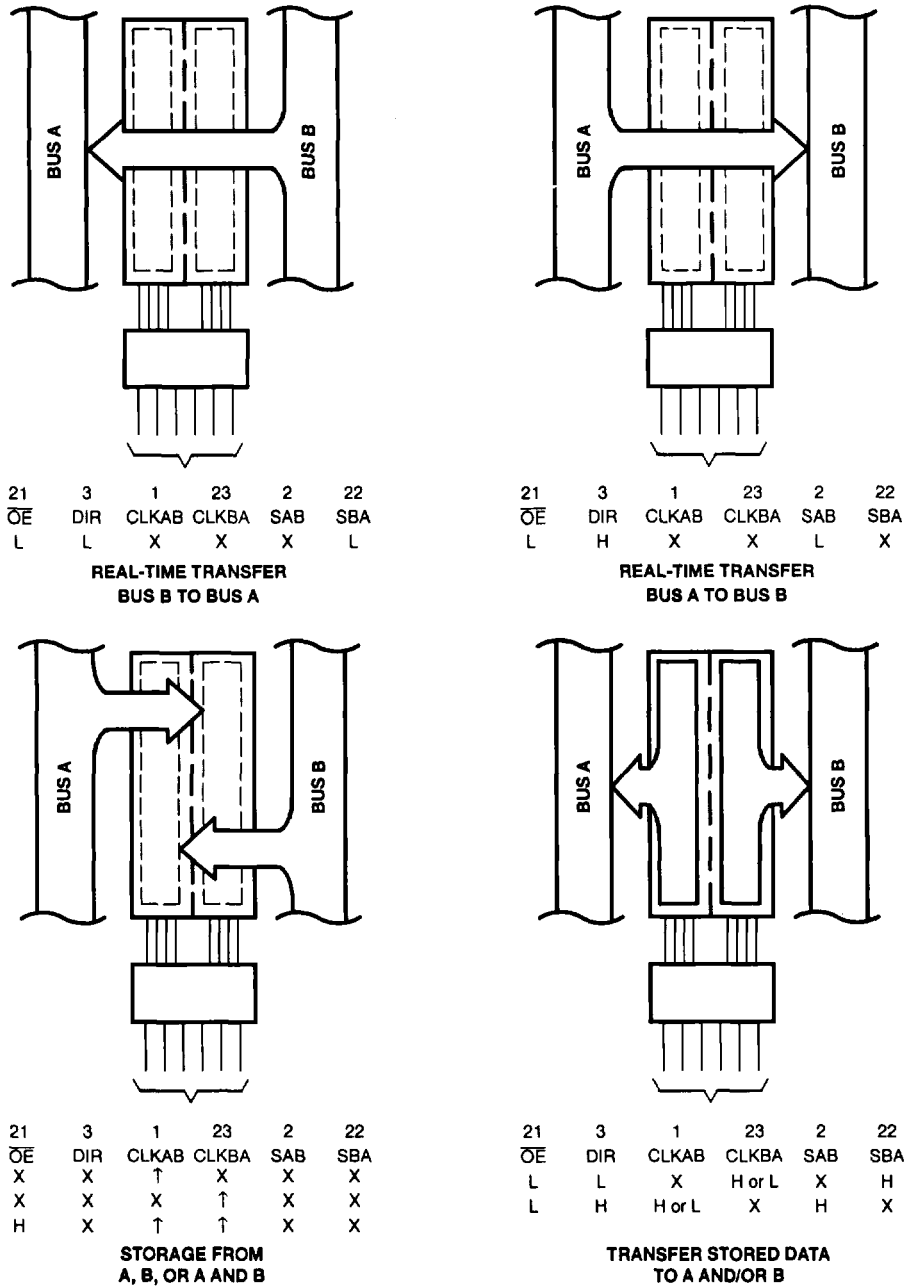

**Figure 1. Bus-Management Functions**

Pin numbers shown are for the DB, DW, JT, PW, and W packages.



POST OFFICE BOX 655303 • DALLAS, TEXAS 75285

# SN54LVT646, SN74LVT646

## 3.3-V ABT OCTAL BUS TRANSCEIVERS AND REGISTERS

### WITH 3-STATE OUTPUTS

SCBS140D - MAY 1992 - REVISED JULY 1995

logic symbol†

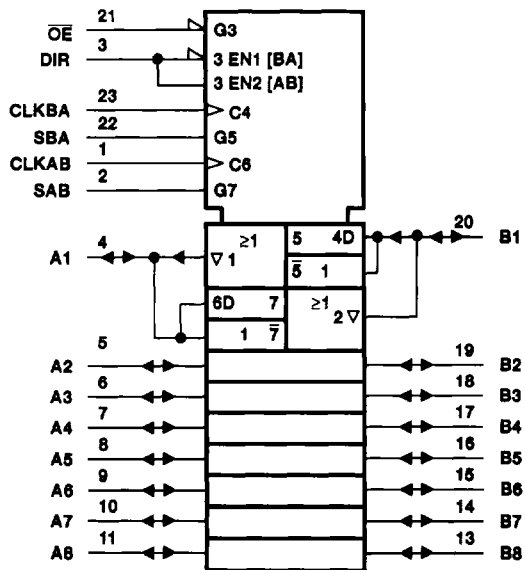

† This symbol is in accordance with ANSI/IEEE Std 91-1984 and IEC Publication 617-12. Pin numbers shown are for the DB, DW, JT, PW, and W packages.

**SN54LVT646, SN74LVT646**  
**3.3-V ABT OCTAL BUS TRANSCEIVERS AND REGISTERS**  
**WITH 3-STATE OUTPUTS**  
 SCBS140D - MAY 1992 - REVISED JULY 1995

**logic diagram (positive logic)**

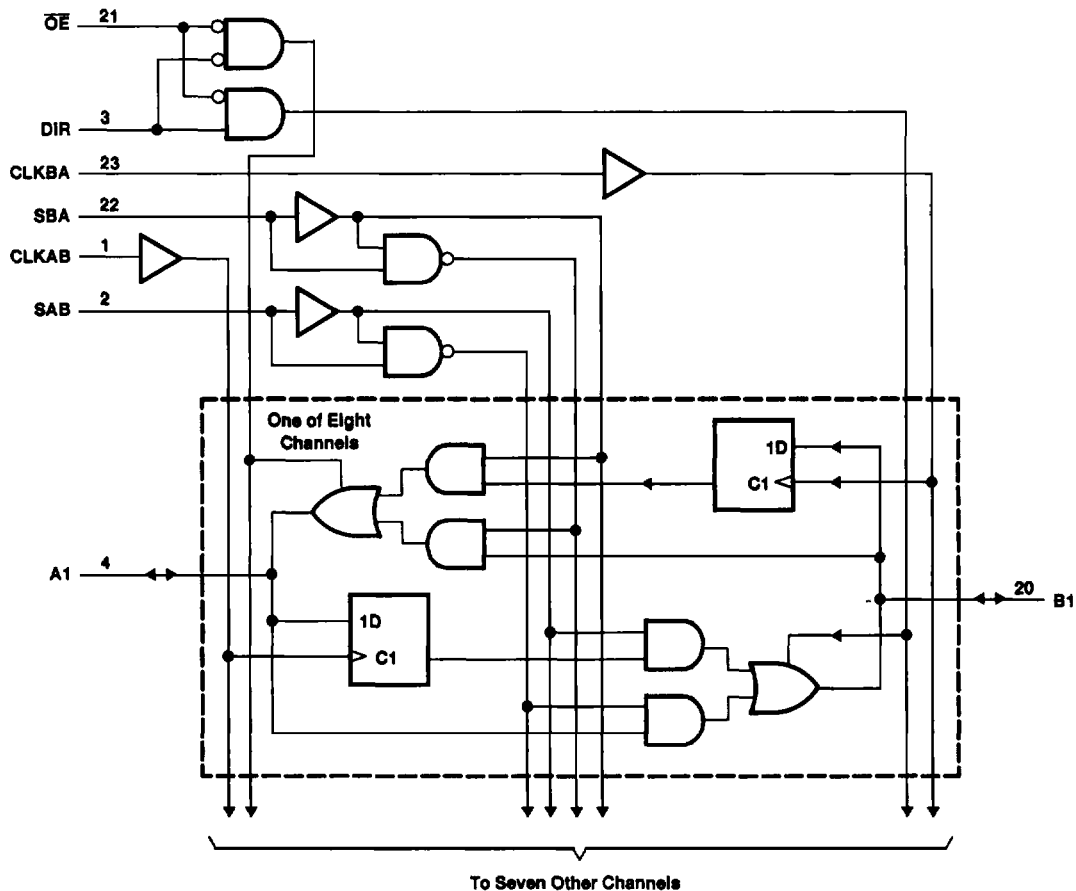

Pin numbers shown are for the DB, DW, JT, PW, and W packages.

**SN54LVT646, SN74LVT646**  
**3.3-V ABT OCTAL BUS TRANSCEIVERS AND REGISTERS**  
**WITH 3-STATE OUTPUTS**

SCBS140D – MAY 1992 – REVISED JULY 1995

**absolute maximum ratings over operating free-air temperature range (unless otherwise noted)†**

Supply voltage range, $V_{CC}$ .....	-0.5 V to 4.6 V
Input voltage range, $V_I$ (see Note 1) .....	-0.5 V to 7 V
Voltage range applied to any output in the high state or power-off state, $V_O$ (see Note 1) .....	-0.5 V to 7 V
Current into any output in the low state, $I_O$ : SN54LVT646 .....	96 mA
SN74LVT646 .....	128 mA
Current into any output in the high state, $I_O$ (see Note 2): SN54LVT646 .....	48 mA
SN74LVT646 .....	64 mA
Input clamp current, $I_{IK}$ ( $V_I < 0$ ) .....	-50 mA
Output clamp current, $I_{OK}$ ( $V_O < 0$ ) .....	-50 mA
Maximum power dissipation at $T_A = 55^\circ\text{C}$ (in still air) (see Note 3): DB package .....	0.65 W
DW package .....	1.7 W
PW package .....	0.7 W
Storage temperature range, $T_{stg}$ .....	-65°C to 150°C

† Stresses beyond those listed under "absolute maximum ratings" may cause permanent damage to the device. These are stress ratings only, and functional operation of the device at these or any other conditions beyond those indicated under "recommended operating conditions" is not implied. Exposure to absolute-maximum-rated conditions for extended periods may affect device reliability.

- NOTES: 1. The input and output negative-voltage ratings may be exceeded if the input and output clamp-current ratings are observed.  
 2. This current flows only when the output is in the high state and  $V_O > V_{CC}$ .  
 3. The maximum package power dissipation is calculated using a junction temperature of 150°C and a board trace length of 750 mils. For more information, refer to the *Package Thermal Considerations* application note in the 1994 *ABT Advanced BiCMOS Technology Data Book*, literature number SCBD002B.

**recommended operating conditions (see Note 4)**

		SN54LVT646		SN74LVT646		UNIT
		MIN	MAX	MIN	MAX	
$V_{CC}$	Supply voltage	2.7	3.6	2.7	3.6	V
$V_{IH}$	High-level input voltage	2		2		V
$V_{IL}$	Low-level input voltage		0.8		0.8	V
$V_I$	Input voltage		5.5		5.5	V
$I_{OH}$	High-level output current		-24		-32	mA
$I_{OL}$	Low-level output current		48		64	mA
$\Delta t/\Delta v$	Input transition rise or fall rate	Outputs enabled		10	10	ns/V
$T_A$	Operating free-air temperature	-55	125	-40	85	°C

NOTE 4: Unused control inputs must be held high or low to prevent them from floating.



POST OFFICE BOX 666303 • DALLAS, TEXAS 75265

# SN54LVT646, SN74LVT646

## 3.3-V ABT OCTAL BUS TRANSCEIVERS AND REGISTERS WITH 3-STATE OUTPUTS

SCBS140D - MAY 1992 - REVISED JULY 1995

electrical characteristics over recommended operating free-air temperature range (unless otherwise noted)

PARAMETER	TEST CONDITIONS		SN54LVT646		SN74LVT646		UNIT	
			MIN	TYP†	MAX	MIN		TYP†
$V_{IK}$	$V_{CC} = 2.7\text{ V}$ ,	$I_I = -18\text{ mA}$				-1.2		V
$V_{OH}$	$V_{CC} = \text{MIN to MAX}^\ddagger$ , $I_{OH} = -100\ \mu\text{A}$		$V_{CC} - 0.2$		$V_{CC} - 0.2$		V	
	$V_{CC} = 2.7\text{ V}$ ,	$I_{OH} = -8\text{ mA}$	2.4		2.4			
	$V_{CC} = 3\text{ V}$	$I_{OH} = -24\text{ mA}$	2					
		$I_{OH} = -32\text{ mA}$			2			
$V_{OL}$	$V_{CC} = 2.7\text{ V}$	$I_{OL} = 100\ \mu\text{A}$			0.2		V	
		$I_{OL} = 24\text{ mA}$			0.5			
	$V_{CC} = 3\text{ V}$	$I_{OL} = 18\text{ mA}$			0.4			
		$I_{OL} = 32\text{ mA}$			0.5			
		$I_{OL} = 48\text{ mA}$			0.55			
		$I_{OL} = 64\text{ mA}$			0.55			
$I_I$	$V_{CC} = 3.6\text{ V}$ ,	$V_I = V_{CC}$ or GND	Control inputs	$\pm 1$		$\pm 1$	$\mu\text{A}$	
	$V_{CC} = 0$ or $\text{MAX}^\ddagger$ ,	$V_I = 5.5\text{ V}$		10		10		
	$V_{CC} = 3.6\text{ V}$	$V_I = 5.5\text{ V}$	A or B ports§	100		20		
		$V_I = V_{CC}$		1		1		
		$V_I = 0$		-5		-5		
$I_{off}$	$V_{CC} = 0$ ,	$V_I$ or $V_O = 0$ to $4.5\text{ V}$			$\pm 100$		$\mu\text{A}$	
$I_I(\text{hold})$	$V_{CC} = 3\text{ V}$	$V_I = 0.8\text{ V}$	A or B ports	75		75	$\mu\text{A}$	
		$V_I = 2\text{ V}$		-75		-75		
$I_{OZH}$	$V_{CC} = 3.6\text{ V}$ ,	$V_O = 3\text{ V}$			1		$\mu\text{A}$	
$I_{OZL}$	$V_{CC} = 3.6\text{ V}$ ,	$V_O = 0.5\text{ V}$			-1		$\mu\text{A}$	
$I_{CC}$	$V_{CC} = 3.6\text{ V}$ , $V_I = V_{CC}$ or GND	$I_O = 0$ ,	Outputs high	0.13	0.39	0.13	0.19	mA
			Outputs low	8.8	14	8.8	12	
			Outputs disabled	0.13	0.39	0.13	0.19	
$\Delta I_{CC}^\ddagger$	$V_{CC} = 3\text{ V to }3.6\text{ V}$ ,	One input at $V_{CC} - 0.6\text{ V}$ , Other inputs at $V_{CC}$ or GND			0.3		0.2	mA
$C_i$	$V_I = 3\text{ V or }0$				4.5		pF	
$C_{io}$	$V_O = 3\text{ V or }0$				11		pF	

† All typical values are at  $V_{CC} = 3.3\text{ V}$ ,  $T_A = 25^\circ\text{C}$ .

‡ For conditions shown as MIN or MAX, use the appropriate value specified under recommended operating conditions.

§ Unused terminals at  $V_{CC}$  or GND

¶ This is the increase in supply current for each input that is at the specified TTL voltage level rather than  $V_{CC}$  or GND.



POST OFFICE BOX 655303 • DALLAS, TEXAS 75285

**SN54LVT646, SN74LVT646**  
**3.3-V ABT OCTAL BUS TRANSCEIVERS AND REGISTERS**  
**WITH 3-STATE OUTPUTS**

SCBS140D - MAY 1992 - REVISED JULY 1995

timing requirements over recommended operating free-air temperature range (unless otherwise noted) (see Figure 2)

		SN54LVT646				SN74LVT646				UNIT
		V <sub>CC</sub> = 3.3 V ± 0.3 V		V <sub>CC</sub> = 2.7 V		V <sub>CC</sub> = 3.3 V ± 0.3 V		V <sub>CC</sub> = 2.7 V		
		MIN	MAX	MIN	MAX	MIN	MAX	MIN	MAX	
f <sub>clock</sub>	Clock frequency	0	150	0	150	0	150	0	150	MHz
t <sub>w</sub>	Pulse duration, CLK high or low	3.3		3.3		3.3		3.3		ns
t <sub>su</sub>	Setup time, A or B before CLKAB↑ or CLKBA↑	Data high	1.5	1.5	1.3	1.3				ns
		Data low	2.5	3.0	2	2.4				
t <sub>h</sub>	Hold time, A or B after CLKAB↑ or CLKBA↑	0.9		0.9		0.4		0.4		ns

switching characteristics over recommended operating free-air temperature range, C<sub>L</sub> = 50 pF (unless otherwise noted) (see Figure 2)

PARAMETER	FROM (INPUT)	TO (OUTPUT)	SN54LVT646				SN74LVT646				UNIT
			V <sub>CC</sub> = 3.3 V ± 0.3 V		V <sub>CC</sub> = 2.7 V		V <sub>CC</sub> = 3.3 V ± 0.3 V		V <sub>CC</sub> = 2.7 V		
			MIN	MAX	MIN	MAX	MIN	TYP†	MAX	MIN	
t <sub>max</sub>			150				150				MHz
t <sub>PLH</sub>	CLKBA or CLKAB	A or B	1.2	5.9	6.9		1.8	3.8	5.7	6.7	ns
t <sub>PHL</sub>			1.2	5.9	6.6		2.1	3.8	5.7	6.4	
t <sub>PLH</sub>	A or B	B or A	0.8	4.9	5.6		1.3	2.8	4.7	5.4	ns
t <sub>PHL</sub>			0.6	4.8	5.5		1	2.7	4.6	5.3	
t <sub>PLH</sub>	SBA or SAB‡	A or B	1	6.4	7.4		1.4	3.7	6.2	7.2	ns
t <sub>PHL</sub>			1	6.4	7		1.4	3.8	6.2	6.8	
t <sub>PZH</sub>	OE	A or B	0.6	6	7.4		1	3	5.8	7.2	ns
t <sub>PZL</sub>			0.6	6.2	7.5		1	3.2	6	7.3	
t <sub>PHZ</sub>	OE	A or B	1.4	6.7	7.1		2.3	4.3	6.5	6.9	ns
t <sub>PLZ</sub>			1.4	6.4	6.5		2.2	3.8	5.8	5.9	
t <sub>PZH</sub>	DIR	A or B	0.6	6.7	7.7		1	3.4	6.5	7.5	ns
t <sub>PZL</sub>			0.8	6.5	7.3		1.2	3.4	6.3	7.1	
t <sub>PHZ</sub>	DIR	A or B	0.8	7.4	8.3		1.7	4.1	7.2	8.1	ns
t <sub>PLZ</sub>			1	6.7	7		1.5	3.5	5.8	6.3	

† All typical values are at V<sub>CC</sub> = 3.3 V, T<sub>A</sub> = 25°C.

‡ These parameters are measured with the internal output state of the storage register opposite to that of the bus input.



POST OFFICE BOX 655303 • DALLAS, TEXAS 75265

# SN54LVT646, SN74LVT646 3.3-V ABT OCTAL BUS TRANSCEIVERS AND REGISTERS WITH 3-STATE OUTPUTS

SCBS140D - MAY 1992 - REVISED JULY 1995

## PARAMETER MEASUREMENT INFORMATION

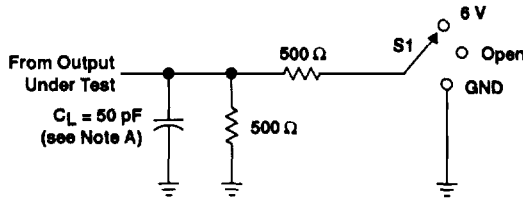

LOAD CIRCUIT FOR OUTPUTS

TEST	S1
$t_{PLH}/t_{PHL}$	Open
$t_{PLZ}/t_{PZL}$	6 V
$t_{PHZ}/t_{PZH}$	GND

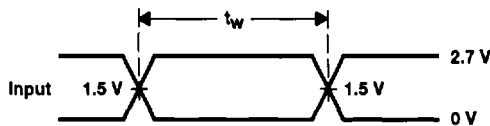

VOLTAGE WAVEFORMS  
PULSE DURATION

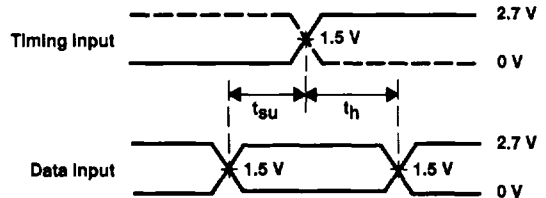

VOLTAGE WAVEFORMS  
SETUP AND HOLD TIMES

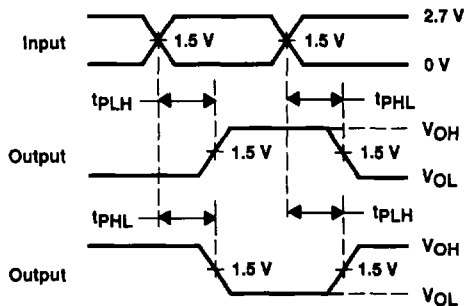

VOLTAGE WAVEFORMS  
PROPAGATION DELAY TIMES  
INVERTING AND NONINVERTING OUTPUTS

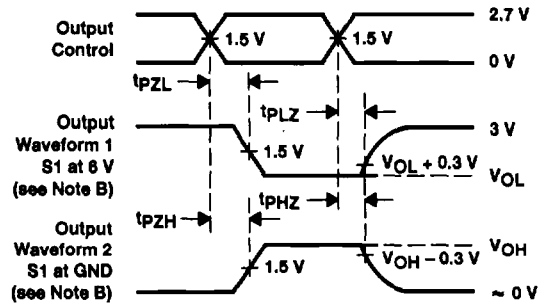

VOLTAGE WAVEFORMS  
ENABLE AND DISABLE TIMES  
LOW- AND HIGH-LEVEL ENABLING

- NOTES: A.  $C_L$  includes probe and jig capacitance.  
 B. Waveform 1 is for an output with internal conditions such that the output is low except when disabled by the output control. Waveform 2 is for an output with internal conditions such that the output is high except when disabled by the output control.  
 C. All input pulses are supplied by generators having the following characteristics: PRR  $\leq 10 \text{ MHz}$ ,  $Z_O = 50 \Omega$ ,  $t_r \leq 2.5 \text{ ns}$ ,  $t_f \leq 2.5 \text{ ns}$ .  
 D. The outputs are measured one at a time with one transition per measurement.

Figure 2. Load Circuit and Voltage Waveforms

