

January 2005



Features

- Data rate up to 3.125 Gbps
- 1310/1550 nm InGaAs PIN photodiode
- Integrated TIA amplifier
- Photocurrent Monitor
- 0.155 to 3.125 Gbps multi-rate operation
- Hermetically sealed package (MIL-STD 883)
- Single 3.3 V supply
- Pb-free packaging

Applications

- SONET/SDH OC-48/STM-16
- SFF and SFP transceiver modules
- Proprietary 1310/1550 nm optical communication links

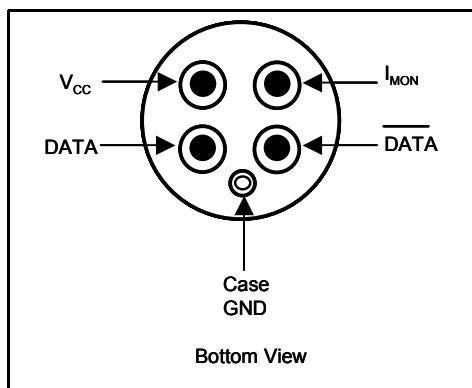

Figure 1 - Pin-out Diagram

Ordering Information

ZL60015TBD, TO-46 with lens

The ZL60015 is also available assembled in standard optical receptacles, or with a 1m 9µm fiber pigtail with or without end-connector

ZL60015TDDB, in ST receptacle
 ZL60015TEDB, in SC receptacle
 ZL60015TFDB, in FC receptacle
 ZL60015TGDB, in SMA receptacle
 ZL60015TJDB in LC-Sleeve

ZL60015PADB, pigtail with no connector
 ZL60015PDDB, pigtail with ST connector
 ZL60015PEDB, pigtail with SC connector
 ZL60015PFDB, pigtail with FC connector
 ZL60015PGDB, pigtail with SMA connector

In addition the ZL60015 can also be supplied in customer-specific fiber pigtails or receptacles, on request

-40°C to +85°C

Description

The ZL60015 is a compact optical receiver designed for 1310/1550 nm based SONET/SDH OC-48/STM-16 applications. It is ideally suited for use in multi-rate transceiver modules as well as general optical communication applications with data rates up to 3.125 Gbps.

The optical receiver is assembled in a single compact TO-46 package and contains an optimized InGaAs PIN photodiode in combination with a low-noise transimpedance amplifier (TIA). It includes an additional pin allowing the photocurrent from the detector to be directly monitored. The receiver operates using a single 3.3 V power supply. It is designed for use with a 9 µm single-mode fiber.

Reliability assurance is based on Telcordia GR-468-CORE and the part is compliant to the EU directive 2002/95/EC issued 27 January 2003 [RoHS].

Optical and Electrical Characteristics

Parameter	Symbol	Min.	Typ.	Max.	Unit	Test condition
Sensitivity (BER 10^{-10})	S		-25	-23	dBm	ER = ∞ Note 1
Optical Saturation (BER 10^{-10})	P_{sat}	1			dBm	ER = 10 dB, Note 1
Photodiode Monitor Responsivity	R_{mon}		0.9		A/W	P_{in} = -10 dBm, See Figure 4
Output Voltage amplitude, differential (P_{in} = -23 dBm)	ΔV_{OL}	20	50		mV, pp	Note 1, ER= 10 dB See Figure 3
Output Voltage amplitude, differential (P_{in} = -3 dBm)	ΔV_{OH}	240		300	mV, pp	Note 1, ER = 10 dB See Figure 3
Bandwidth (3 dB _{el})	f_C		2		GHz	P_{in} = -10 dBm
Noise-Equivalent Power	NEP		-32	-30	dBm	Note 2
Output Resistance (single-ended)	R_{out}		50		Ω	
Power Supply Current	I_{DD}		25	38	mA	
Power Dissipation	P_D		85	140	mW	
Focal distance (from top TO-can)	L_{focal}		2.0		mm	

General Test Conditions: Case Temperature, 25°C / Supply Voltage, 3.3V / R_L = 100 Ω differential / Fiber: single-mode 9/125 μ m / Wavelength, λ = 1310 nm

Note 1: Measured using 2^{23} -1 PRBS pattern at 2.5 Gbps

Note 2: Measured with an STM-16 filter on electrical output, i.e., 1.875 GHz.

Recommended Operating Conditions

Parameter	Symbol	Min.	Typ.	Max.	Unit
Supply Voltage	V_{CC}	3		3.6	V
Output Differential Load (Note 3)	R_L	80	100		Ω
Operating Temperature	T_{op}	-40		85	°C
Signalling Rate (Note 4)	f_D	0.155		3.125	Gbps

Note 3: Typical value corresponds to the load presented by a following post-amplifier

Note 4: Data pattern having maximum run-length and DC-balance shifts no greater than those found in a PRBS-31 pattern.

Absolute Maximum Ratings

Functional operation is not guaranteed under these conditions. Exceeding these ratings may cause permanent damage. (Note limits need not necessarily be applied together).

Parameter	Symbol	Min.	Max.	Unit
Supply Voltage	V_{CC}	0	5	V
Storage Temperature	T_{stg}	-55	125	°C
Soldering Temperature (Note 5)	T_{sld}		260	°C

Note 5: 2mm from case for 10 seconds.

Additional Information

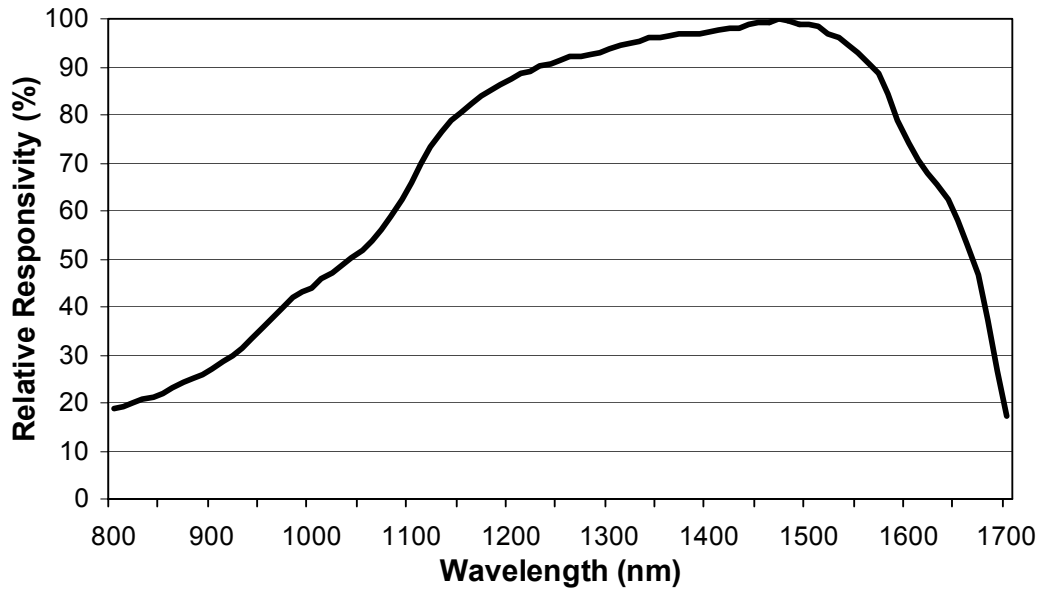

Figure 2 - Relative Detector Responsivity vs. Wavelength

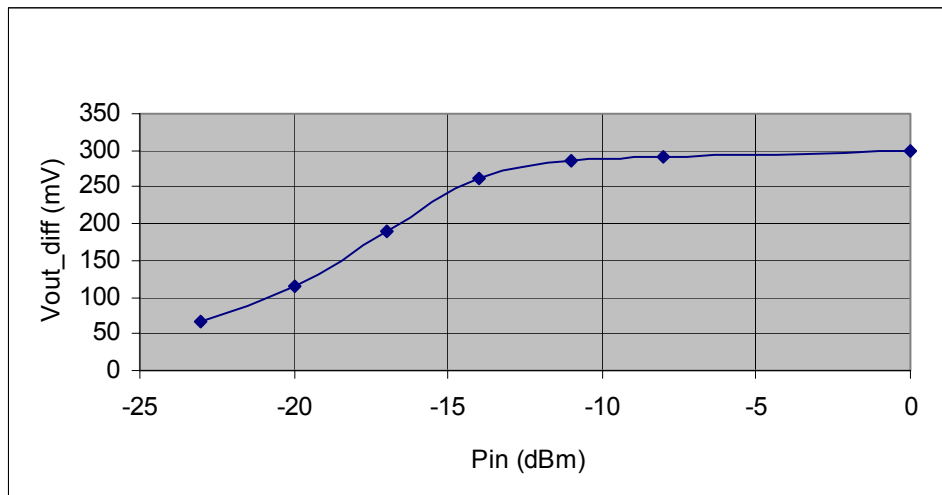

Figure 3 - Differential Output Voltage Amplitude vs. Optical Input Power

Application Guidelines

ESD Handling



The receiver is sensitive to electrostatic discharges. When handling the device, precaution for ESD sensitive devices should be taken. These precautions include use of ESD protected work area with wrist straps, controlled work benches, floors etc.

Photodiode Monitor

The Monitor pin is a current sink output signal directly proportional to the optical input power. To convert the current from the Monitor pin to a voltage a resistor to V_{CC} should be used. Note to maintain linearity the Monitor pin should, when in use, be maintained at a bias $> 1V$.

Host Board Layout Example

Included in the example of a Host Board Layout (Figure 4) are power supply decoupling capacitors. These are recommended for optimal performance of the receiver. A filter is also included to minimise power supply noise.

A suggested post-amplifier is shown, namely MAX3748. Alternative post-amplifiers may also be used by the customer.

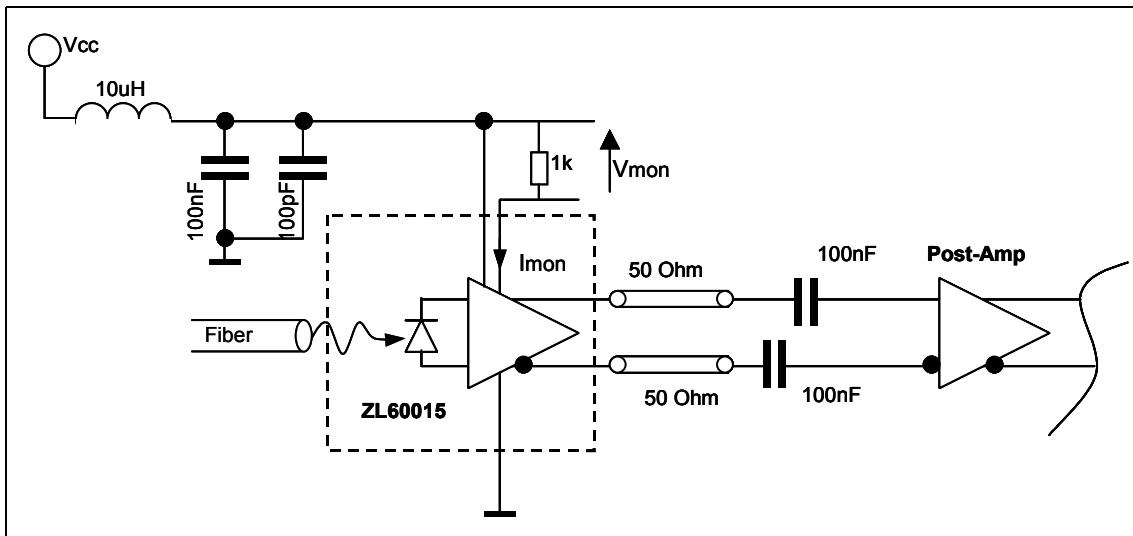
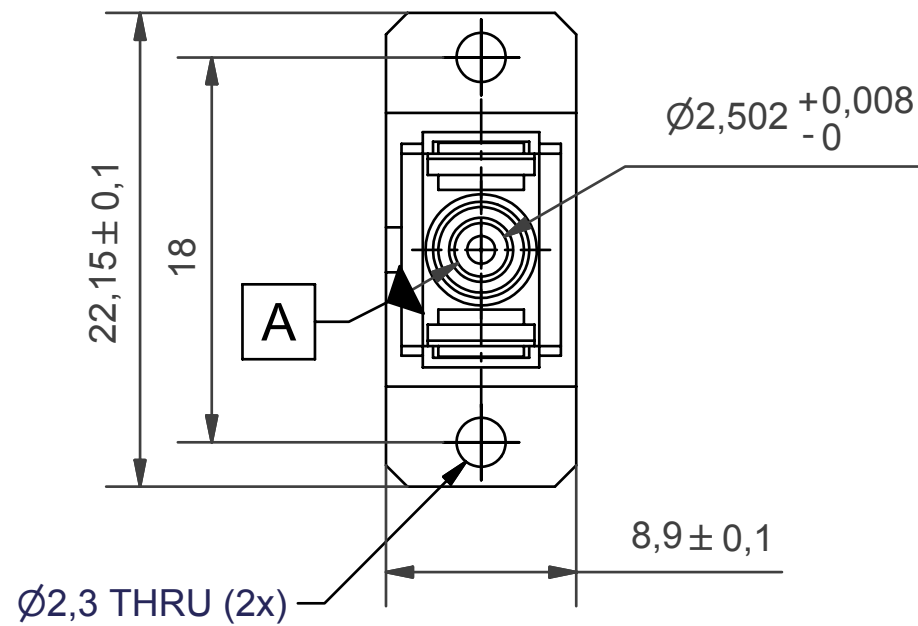
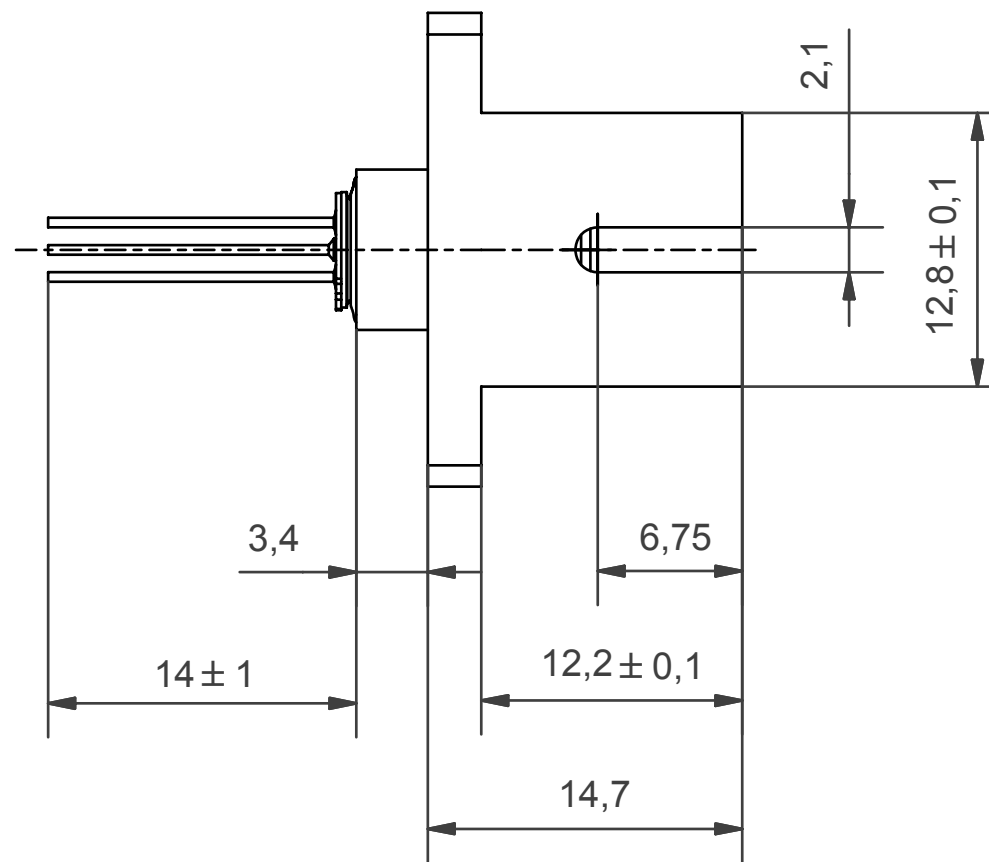

Figure 4 - Host Board Layout Example

FRONT VIEW (2 : 1)



SIDE VIEW



BOTTOM VIEW

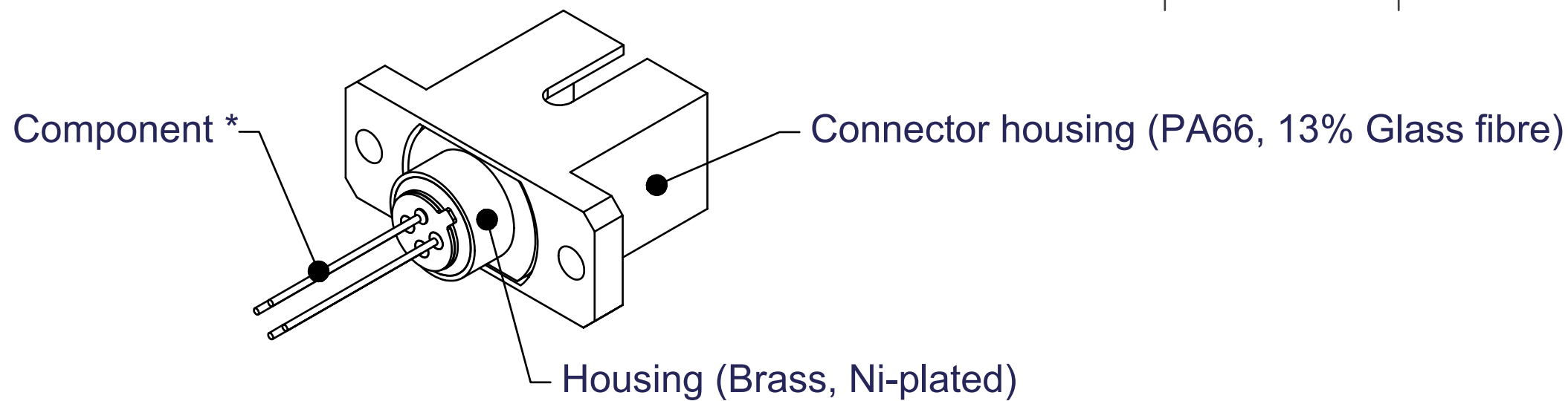
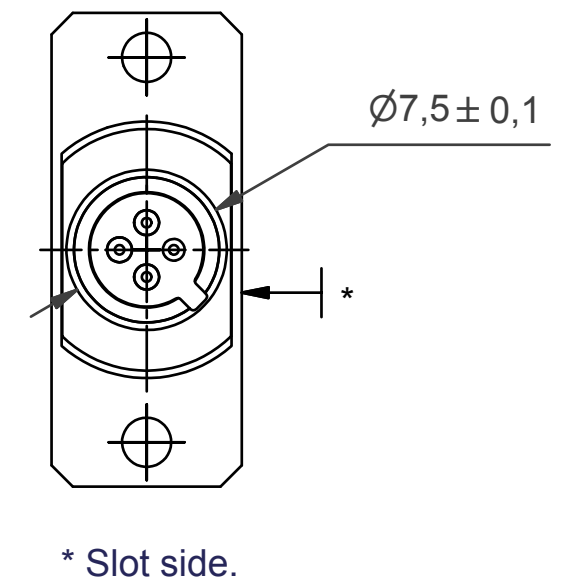

NOTES:-

1. All dimensions in mm.
2. General tol. ISO-2768-mK.

* For details of the component, see separate data sheet and/or package drawing.

Projection Method

© Zarlink Semiconductor 2002. All rights reserved.

ISSUE	1			
ACN	102546rev 1			
DATE	9-DEC-03			
APPRD.	MD/MA			



	Package code TE
Previous package codes	Drawing type TO-46 Package Outline in SC Connector housing
	Title 102546

BOTTOM VIEW (10 : 1)

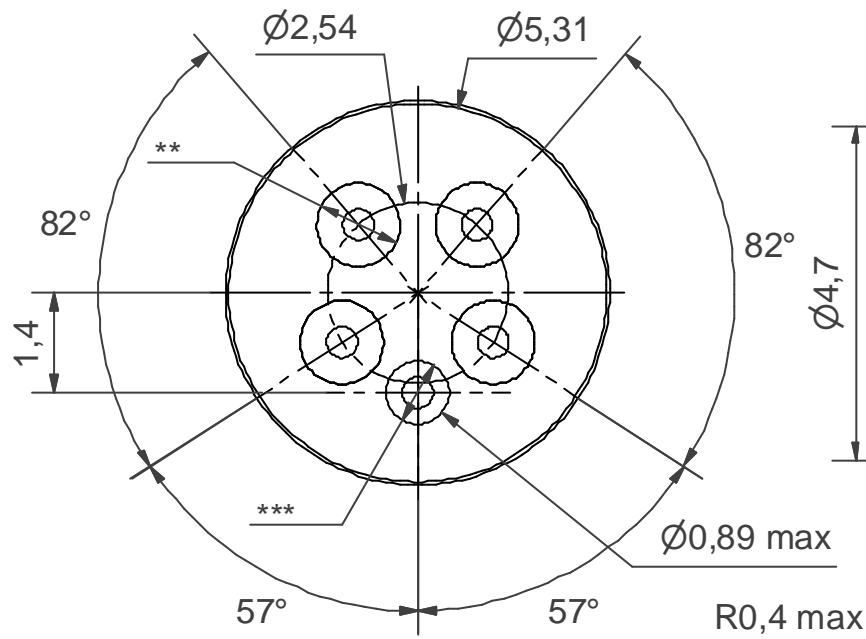

SIDE VIEW

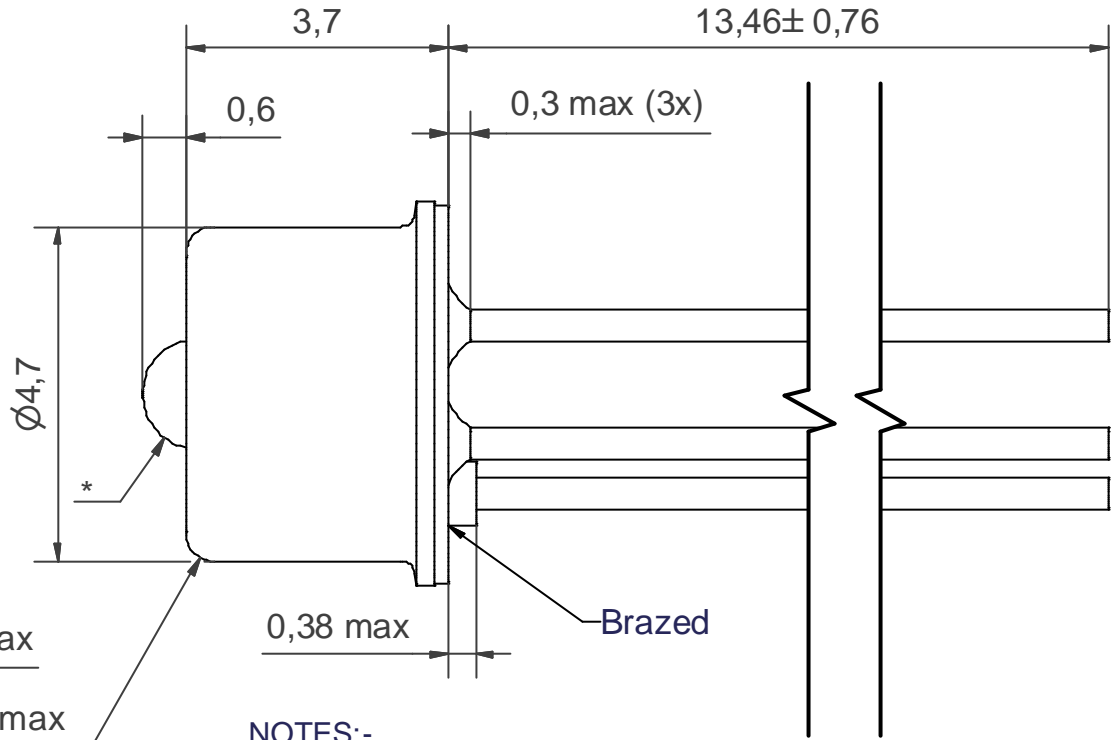

NOTES:-

1. All dimensions in mm.
2. General tol. ISO-2768-mK.
3. Coating: Case: Ni 1,5-2,5 μ m.
Header: Ni 2-3 μ m / Au min 0.8 μ m.

* Lens $\varnothing 1.5 \pm 0.05$

** Glass sealing (4x): $\varnothing 1,17 +0.05$

*** Lead (5x): $\varnothing 0,44 +0.05/-0,025$

© Zarlink Semiconductor 2002. All rights reserved.

ISSUE	1			
ACN	JS004172R1A			
DATE	29-APR-03			
APPRD.	TD/BE			



	Package code TB
Previous package codes	Drawing type Package drawing, TO-46 with lens
	Title JS004172



**For more information about all Zarlink products
visit our Web Site at
www.zarlink.com**

Information relating to products and services furnished herein by Zarlink Semiconductor Inc. or its subsidiaries (collectively "Zarlink") is believed to be reliable. However, Zarlink assumes no liability for errors that may appear in this publication, or for liability otherwise arising from the application or use of any such information, product or service or for any infringement of patents or other intellectual property rights owned by third parties which may result from such application or use. Neither the supply of such information or purchase of product or service conveys any license, either express or implied, under patents or other intellectual property rights owned by Zarlink or licensed from third parties by Zarlink, whatsoever. Purchasers of products are also hereby notified that the use of product in certain ways or in combination with Zarlink, or non-Zarlink furnished goods or services may infringe patents or other intellectual property rights owned by Zarlink.

This publication is issued to provide information only and (unless agreed by Zarlink in writing) may not be used, applied or reproduced for any purpose nor form part of any order or contract nor to be regarded as a representation relating to the products or services concerned. The products, their specifications, services and other information appearing in this publication are subject to change by Zarlink without notice. No warranty or guarantee express or implied is made regarding the capability, performance or suitability of any product or service. Information concerning possible methods of use is provided as a guide only and does not constitute any guarantee that such methods of use will be satisfactory in a specific piece of equipment. It is the user's responsibility to fully determine the performance and suitability of any equipment using such information and to ensure that any publication or data used is up to date and has not been superseded. Manufacturing does not necessarily include testing of all functions or parameters. These products are not suitable for use in any medical products whose failure to perform may result in significant injury or death to the user. All products and materials are sold and services provided subject to Zarlink's conditions of sale which are available on request.

Purchase of Zarlink's I²C components conveys a licence under the Philips I²C Patent rights to use these components in and I²C System, provided that the system conforms to the I²C Standard Specification as defined by Philips.

Zarlink, ZL and the Zarlink Semiconductor logo are trademarks of Zarlink Semiconductor Inc.

Copyright Zarlink Semiconductor Inc. All Rights Reserved.

TECHNICAL DOCUMENTATION - NOT FOR RESALE
