

Or, Call Customer Service at 1-800-548-6132 (USA Only)

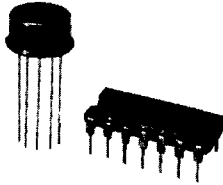

MPY534

Precision ANALOG MULTIPLIER

FEATURES

- $\pm 0.25\%$ max 4-QUADRANT ACCURACY
- WIDE BANDWIDTH: 1MHz min, 3MHz typ
- ADJUSTABLE SCALE FACTOR
- STABLE AND RELIABLE MONOLITHIC CONSTRUCTION
- LOW COST

APPLICATIONS

- PRECISION ANALOG SIGNAL PROCESSING
- VIDEO SIGNAL PROCESSING
- VOLTAGE CONTROLLED FILTERS AND OSCILLATORS
- MODULATION AND DEMODULATION
- RATIO AND PERCENTAGE COMPUTATION

DESCRIPTION

The MPY534 is a high accuracy, general purpose four-quadrant analog multiplier. Its accurately laser trimmed transfer characteristics make it easy to use in a wide variety of applications with a minimum of external parts and trimming circuitry. Its differential X, Y and Z inputs allow configuration as multiplier, squarer, divider, square-rooter and other functions while maintaining high accuracy.

The wide bandwidth of this new design allows accurate signal processing at higher frequencies suitable for video signal processing. It is capable of performing IF and RF frequency mixing, modulation and demodulation with excellent carrier rejection and very simple feedthrough adjustment.

An accurate internal voltage reference provides precise setting of the scale factor. The differential Z input allows user selected scale factors from 0.1 to 10 using external feedback resistors.

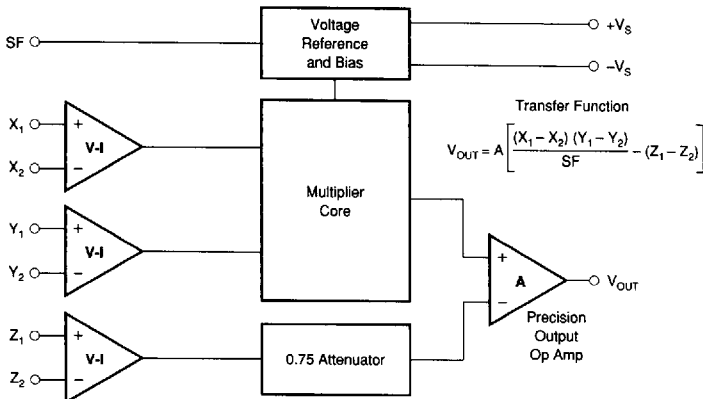

International Airport Industrial Park • Mailing Address: PO Box 11400 • Tucson, AZ 85734 • Street Address: 6730 S. Tucson Blvd. • Tucson, AZ 85706
Tel: (602) 746-1111 • Twx: 910-952-1111 • Cable: BBRCORP • Telex: 066-6481 • FAX: (602) 889-1510 • Immediate Product Info: (800) 548-6132



PDS-614C

1731365 0028623 805

7.49

MPY534

7

SPECIAL FUNCTIONS

For Immediate Assistance, Contact Your Local Salesperson

SPECIFICATIONS

ELECTRICAL

T_A = +25°C and V_S = ±15VDC, unless otherwise specified.

PARAMETER	MPY534J			MPY534K			MPY534L			MPY534S			MPY534T			UNITS
	MIN	TYP	MAX	MIN	TYP	MAX	MIN	TYP	MAX	MIN	TYP	MAX	MIN	TYP	MAX	
MULTIPLIER PERFORMANCE Transfer Function		*		$(X_1 - X_2)(Y_1 - Y_2) + Z_2$				*			*			*		
Total Error ⁽¹⁾ (-10V ≤ X, Y ≤ +10V) T _A = min to max		±1.5	±1.0		±1.0	±0.5		±0.5	±0.25		±1.0	±2.0		*	±1.0	%
Total Error vs Temperature		±0.022			±0.015			±0.008			±0.02			*	±0.01	%/°C
Scale Factor Error (SF = 10.000V Nominal) ⁽²⁾		±0.25			±0.1			*			±0.25			*		%
Temperature Coefficient of Scaling Voltage		±0.02			±0.01			±0.005			±0.02			±0.005		%/°C
Supply Rejection (±15V ±1V)		*			±0.01			*			*			*		%
Nonlinearity: X (X = 20Vp-p, Y = 10V) Y (Y = 20Vp-p, X = 10V)		±0.4			±0.2	±0.3		±0.10	±0.12		±0.4			*	*	%
Feedthrough ⁽³⁾ X (Y Nulled, Y = 20Vp-p 50Hz) Y (X Nulled, Y = 20Vp-p 50Hz)		±0.3			±0.15	±0.3		±0.05	±0.12		±0.3			*	*	%
Output Offset Voltage		±5	±30		±0.01	±0.1		±0.003	*		*			*	*	mV
Output Offset Voltage Drift		200			±2	±15		*	±10		±5	±30		*	*	μV/°C
DYNAMICS Small Signal BW, (V _{OUT} = 0.1Vrms) 1% Amplitude Error (C _{LOAD} = 1000pF) Slew Rate (V _{OUT} = 20Vp-p) Settling Time (to 1%, ΔV _{OUT} = 20V)	*	*		1	3			*			*	*		*	*	MHz
		*			50			*			*	*		*	*	kHz
		*			20			*			*	*		*	*	V/μs
		*			2			*			*	*		*	*	μs
NOISE Noise Spectral Density: SF = 10V Wideband Noise: f = 10Hz to 5MHz f = 10Hz to 10kHz		*			0.8			*			*	*		*	*	μV/√Hz
		*			1			*			*	*		*	*	mVrms
		*			90			*			*	*		*	*	μVrms
OUTPUT Output Voltage Swing Output Impedance (f ≤ 1kHz) Output Short Circuit Current (R _L = 0, T _A = min to max) Amplifier Open Loop Gain (f = 50Hz)	*	*		±11				*			*	*		*	*	V
		*			0.1			*			*	*		*	*	Ω
		*			30			*			*	*		*	*	mA
		*			70			*			*	*		*	*	dB
INPUT AMPLIFIERS (X, Y and Z) Input Voltage Range Differential V _{IN} (V _{CM} = 0) Common-Mode V _{IN} (V _{DIFF} = 0) (see Typical Performance Curves) Offset Voltage X, Y Offset Voltage Drift X, Y Offset Voltage Z Offset Voltage Drift Z CMRR Bias Current Offset Current Differential Resistance					±12	±10		*	*		*	*		*	*	V
		*			±10			*	*		*	*		*	*	V
		±5	±20		±2	±10		*	*		±5	±20		*	*	mV
		100			50			*	*		100			*	*	μV/°C
		±5	±30		±2	±15		*	±10		±5	±30		*	*	mV
		200			100			*	*		500			*	*	μV/°C
	60	80		70	90		*	*	*	60	80		*	*	*	dB
		*	*		0.8	2.0		*	*		*	*		*	*	μA
		*			0.1			0.05	0.2		*	2.0		*	*	μA
		*			10			*	*		*	*		*	*	MΩ
DIVIDER PERFORMANCE Transfer Function (X ₁ > X ₂)		*		$10V \frac{(Z_2 - Z_1)}{(X_1 - X_2)} + Y_1$												
Total Error ⁽¹⁾ (X = 10V, -10V ≤ Z ≤ +10V)		±0.75			±0.35			±0.2			±0.75			*		%
(X = 1V, -1V ≤ Z ≤ +1V)		±2.0			±1.0			±0.8			±2.0			*		%
(0.1V ≤ X ≤ 10V, -10V ≤ Z ≤ 10V)		±2.5			±1.0			±0.8			±2.5			*		%

Or, Call Customer Service at 1-800-548-6132 (USA Only)

SPECIFICATIONS (CONT)

ELECTRICAL

T_a = +25°C and V_s = ±15VDC, unless otherwise specified.

PARAMETER	MPY534J			MPY534K			MPY534L			MPY534S			MPY534T			UNITS
	MIN	TYP	MAX	MIN	TYP	MAX	MIN	TYP	MAX	MIN	TYP	MAX	MIN	TYP	MAX	
SQUARE PERFORMANCE																
Transfer Function	*			$\frac{(X_1 - X_2)^2}{10V} + Z_2$			*			*			*			
Total Error (-10V ≤ X ≤ 10V)		0.6		±0.3				±0.2		±0.6				*		%
SQUARE-ROOTER PERFORMANCE																
Transfer Function (Z ₁ ≤ Z ₂)	*			$\sqrt{10V(Z_2 - Z_1) + X_2}$			*			*			*			
Total Error ⁽¹⁾ (1V ≤ Z ≤ 10V)		±1.0		±0.5				±0.25		±1.0				±0.5		%
POWER SUPPLY																
Supply Voltage:																
Rated Performance	*	*	*	±8	±15		*	*	*	*	*	*	*	*	*	VDC
Operating	*	*	*		4	±18	*	*	*	*	*	*	±20	*	*	VDC
Supply Current, Quiescent	*	*	*			6	*	*	*	*	*	*	*	*	±20	mA
TEMPERATURE RANGE																
Operating	*	*	*			+70	*	*	*	-55		+125	-55		+125	°C
Storage	*	*	*	-65		+150	*	*	*	*	*	*	*	*	*	°C

*Specifications same as for MPY534K.

NOTES: (1) Figures given are percent of full scale, ±10V (i.e., 0.01% = 1mV). (2) May be reduced to 3V using external resistor between -V_s and SF. (3) Irreducible component due to nonlinearity; excludes effect of offsets.

PIN CONFIGURATIONS

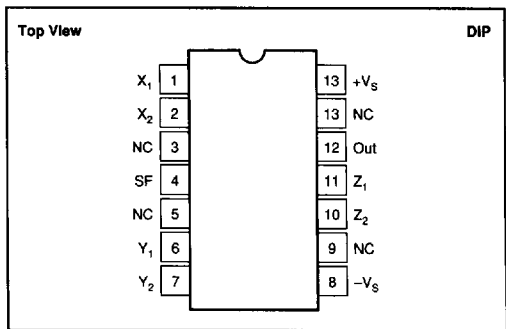
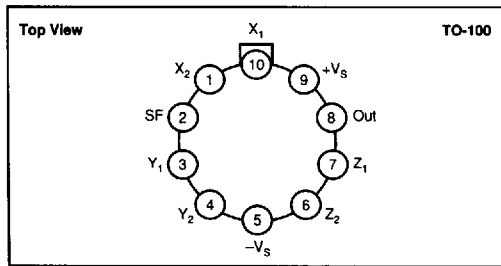

ABSOLUTE MAXIMUM RATINGS

PARAMETER	MPY534J, K, L	MPY534S, T
Power Supply Voltage	±18	±20
Power Dissipation	500mW	*
Output Short-Circuit to Ground	Indefinite	*
Input Voltage (all X, Y and Z)	±V _s	*
Operating Temperature Range	0°C to +70°C	-55°C to +125°C
Storage Temperature Range	-65°C to +150°C	*
Lead Temperature (soldering, 10s)	+300°C	*

*Specification same as for MPY534K.

PACKAGE INFORMATION⁽¹⁾

MODEL	PACKAGE	PACKAGE DRAWING NUMBER
MPY534JD	Ceramic DIP	169
MPY534JH	Metal TO-100	007
MPY534KD	Ceramic DIP	169
MPY534KH	Metal TO-100	007
MPY534LD	Ceramic DIP	169
MPY534LH	Metal TO-100	007
MPY534SD	Ceramic DIP	169
MPY534SH	Metal TO-100	007
MPY534TD	Ceramic DIP	169
MPY534TH	Metal TO-100	007

NOTE: (1) For detailed drawing and dimension table, please see end of data sheet, or Appendix D of Burr-Brown IC Data Book.

ORDERING INFORMATION

MODEL	PACKAGE	TEMPERATURE RANGE
MPY534JD	Ceramic DIP	0°C to +70°C
MPY534JH	Metal TO-100	0°C to +70°C
MPY534KD	Ceramic DIP	0°C to +70°C
MPY534KH	Metal TO-100	0°C to +70°C
MPY534LD	Ceramic DIP	0°C to +70°C
MPY534LH	Metal TO-100	0°C to +70°C
MPY534SD	Ceramic DIP	-55°C to +125°C
MPY534SH	Metal TO-100	-55°C to +125°C
MPY534TD	Ceramic DIP	-55°C to +125°C
MPY534TH	Metal TO-100	-55°C to +125°C



For Immediate Assistance, Contact Your Local Salesperson

DICE INFORMATION

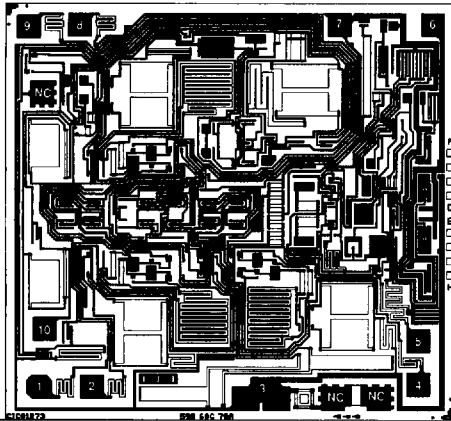

MPY534 DIE TOPOGRAPHY

PAD	FUNCTION
1	Y_1
2	Y_2
3	$-V_S$
4	Z_2
5	Z_1
6	Output
7	$+V_S$
8	X_1
9	X_2
10	SF (Scale Factor)

Substrate Bias: The back of the die should not be used for the $-V_S$ connection. NC = No Connection.

MECHANICAL INFORMATION

	MILS (0.001")	MILLIMETERS
Die Size	100 x 92 ±5	2.54 x 2.34 ±0.13
Die Thickness	20 ±3	0.51 ±0.08
Min. Pad Size	4 x 4	0.10 x 0.10
Backing		Gold

TYPICAL PERFORMANCE CURVES

$T_A = +25^\circ\text{C}$, $V_S = \pm 15\text{VDC}$, unless otherwise noted.

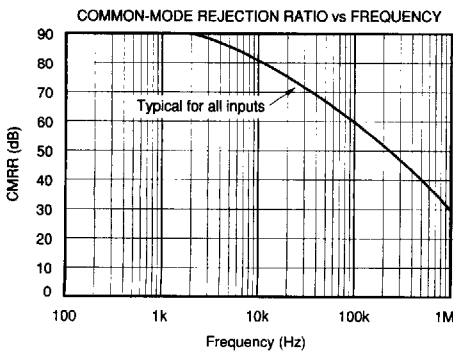
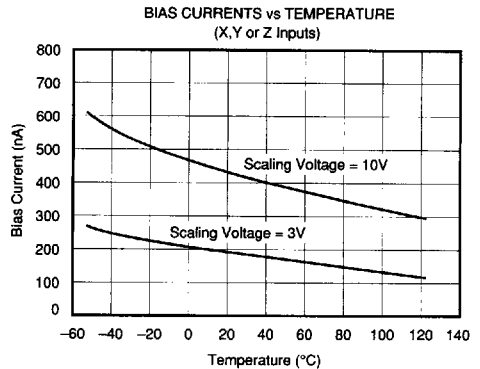
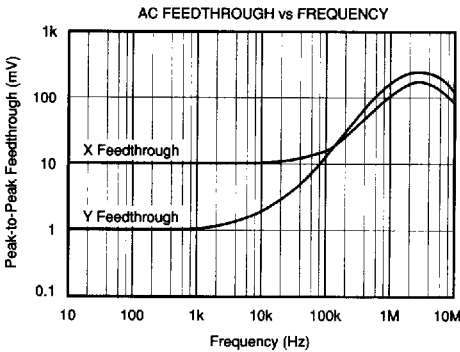

INPUT DIFFERENTIAL-MODE/COMMON-MODE VOLTAGE

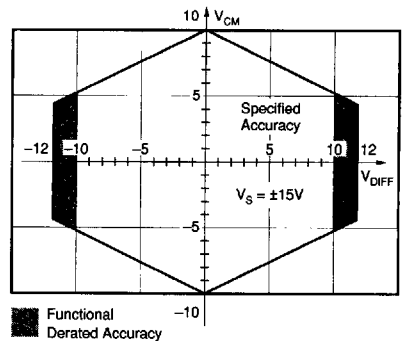

Or, Call Customer Service at 1-800-548-6132 (USA Only)

TYPICAL PERFORMANCE CURVES (CONT)

$T_A = +25^\circ\text{C}$, $\pm V_{CC} = 15\text{VDC}$, unless otherwise noted.

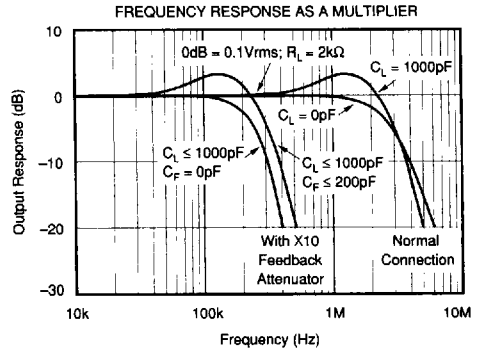
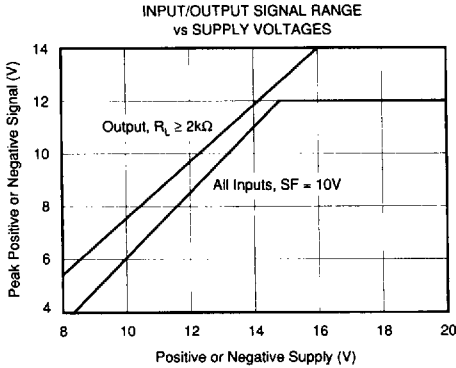
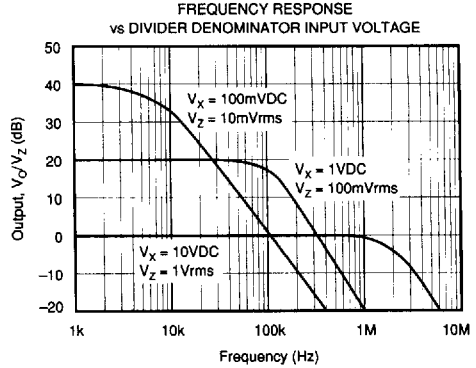
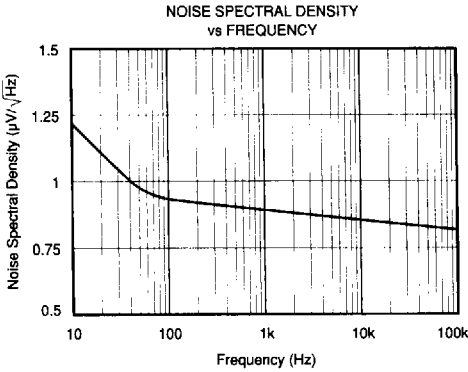

THEORY OF OPERATION

The transfer function for the MPY534 is:

$$V_{OUT} = A \left[\frac{(X_1 - X_2)(Y_1 - Y_2)}{SF} - (Z_1 - Z_2) \right]$$

where:

A = Open-loop gain of the output amplifier (typically 85dB at DC).

SF = Scale Factor. Laser-trimmed to 10V but adjustable over a 3V to 10V range using external resistor.

X, Y, A are input voltages. Full-scale input voltage is equal to the selected SF. (Max input voltage = ± 1.25 SF.)

An intuitive understanding of transfer function can be gained by analogy to an op amp. By assuming that the open-loop gain, A, of the output amplifier is infinite, inspection of the transfer function reveals that any V_{OUT} can be created with an infinitesimally small quantity within the brackets. Then,

an application circuit can be analyzed by assigning circuit voltages for all X, Y and Z inputs and setting the bracketed quantity equal to zero. For example, the basic multiplier connection in Figure 1, $Z_1 = V_{OUT}$ and $Z_2 = 0$. The quantity within the brackets then reduces to:

$$\frac{(X_1 - X_2)(Y_1 - Y_2)}{SF} - (V_{OUT} - 0) = 0$$

This approach leads to a simple relationship which can be solved for V_{OUT} .

The scale factor is accurately factory-adjusted to 10V and is typically accurate to within 0.1% or less. The scale factor may be adjusted by connecting a resistor or potentiometer between pin SF and the $-V_S$ power supply. The value of the external resistor can be approximated by:

$$R_{SF} = 5.4\text{k}\Omega \left[\frac{SF}{10 - SF} \right]$$

For Immediate Assistance, Contact Your Local Salesperson

Internal device tolerances make this relationship accurate to within approximately 25%. Some applications can benefit from reduction of the SF by this technique. The reduced input bias current and drift achieved by this technique can be likened to operating the input circuitry in a higher gain, thus reducing output contributions to these effects. Adjustment of the scale factor does not affect bandwidth.

The MPY534 is fully characterized at $V_s = \pm 15V$, but operation is possible down to $\pm 8V$ with an attendant reduction of input and output range capability. Operation at voltages greater than $\pm 15V$ allows greater output swing to be achieved by using an output feedback attenuator (Figure 2).

BASIC MULTIPLIER CONNECTION

Figure 1 shows the basic connection as a multiplier. Accuracy is fully specified without any additional user trimming circuitry. Some applications can benefit from trimming one or more of the inputs. The fully differential inputs facilitate referencing the input quantities to the source voltage common terminal for maximum accuracy. They also allow use of simple offset voltage trimming circuitry as shown on the X input.

The differential Z input allows an offset to be summed in V_{OUT} . In basic multiplier operation, the Z_2 input serves as the output voltage reference and should be connected to the ground reference of the driven system for maximum accuracy.

A method of changing (lowering) SF by connecting to the SF pin was discussed previously. Figure 2 shows another method of changing the effective SF of the overall circuit using an attenuator in the feedback connection to Z_1 . This method puts the output amplifier in a higher gain and is thus accompanied by a reduction in bandwidth and an increase in output offset voltage. The larger output offset may be reduced by applying a trimming voltage to the high impedance input Z_2 .

The flexibility of the differential Z inputs allows direct conversion of the output quantity to a current. Figure 3 shows the output voltage differentially-sensed across a series resistor forcing an output-controlled current. Addition of a capacitor load then creates a time integration function useful in a variety of applications such as power computation.

SQUARER CIRCUIT

Squarer operation is achieved by paralleling the X and Y inputs of the standard multiplier circuit. Inverted output can be achieved by reversing the differential input terminals of either the X or Y input. Accuracy in the squaring mode is typically a factor of two better than the specified multiplier mode with maximum error occurring with small (less than 1V) inputs. Better accuracy can be achieved for small input voltage levels by using a reduced SF value.

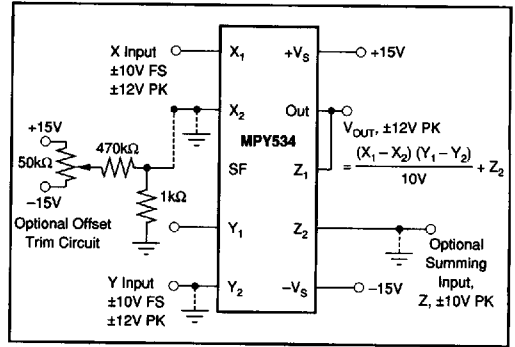

FIGURE 1. Basic Multiplier Connection.

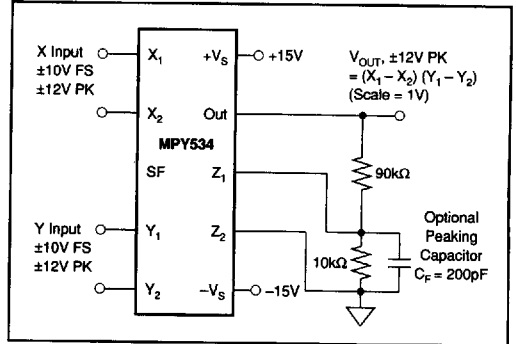

FIGURE 2. Connections for Scale-Factor of Unity.

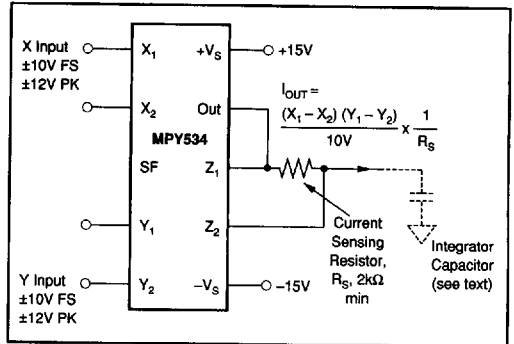

FIGURE 3. Conversion of Output to Current.

DIVIDER CIRCUIT

The MPY534 can be configured as a divider as shown in Figure 4. High impedance differential inputs for the numerator and denominator are achieved at the Z and X inputs, respectively. Feedback is applied to the Y_2 input, and Y_1 can be summed directly into V_{OUT} . Since the feedback connection is made to a multiplying input, the effective gain of the output op amp varies as a function of the denominator input voltage. Therefore, the bandwidth of the divider function is proportional to the denominator voltage (see Typical Performance Curves).

1731365 0028628 397

Or, Call Customer Service at 1-800-548-6132 (USA Only)

Accuracy of the divider mode typically ranges from 0.75% to 2.0% for a 10 to 1 denominator range depending on device grade. Accuracy is primarily limited by input offset voltages and can be significantly improved by trimming the offset of the X input. A trim voltage of $\pm 3.5\text{mV}$ applied to the "low side" X input (X_2 for positive input voltages on X_1) can produce similar accuracies over a 100 to 1 denominator range. To trim, apply a signal which varies from 100mV to 10V at a low frequency (less than 500Hz) to both inputs. An offset sine wave or ramp is suitable. Since the ratio of the quantities should be constant, the ideal output would be a constant 10V. Using AC coupling on an oscilloscope, adjust the offset control for minimum output voltage variation.

APPLICATIONS

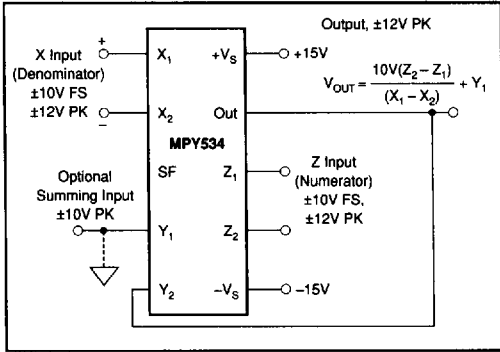

FIGURE 4. Basic Divider Connection.

SQUARE-ROOTER

A square-rooter connection is shown in Figure 5. Input voltage is limited to one polarity (positive for the connection shown). The diode prevents circuit latch-up should the input go negative. The circuit can be configured for negative input and positive output by reversing the polarity of both the X and Y inputs. The output polarity can be reversed by reversing the diode and X input polarity. A load resistance of approximately 10k Ω must be provided. Trimming for improved accuracy would be accomplished at the Z input.

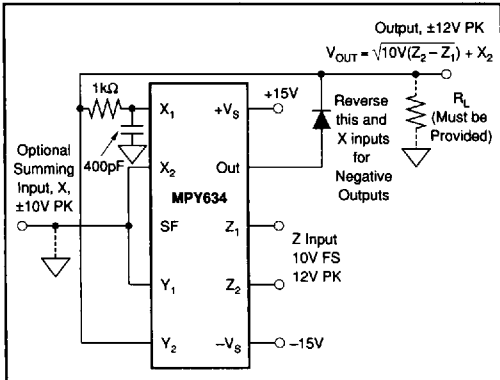

FIGURE 5. Square-Rooter Connection.

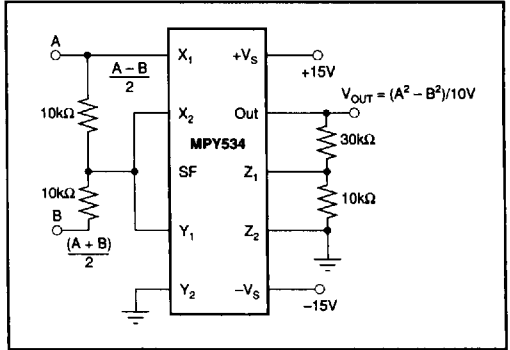
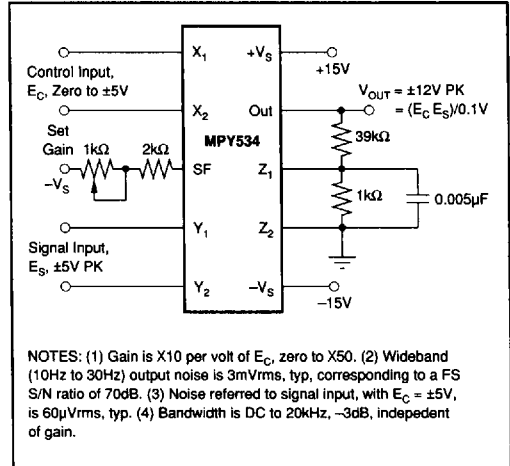

FIGURE 6. Difference-of-Squares.



NOTES: (1) Gain is X10 per volt of E_C , zero to X50. (2) Wideband (10Hz to 30Hz) output noise is 3mVrms, typ, corresponding to a FS S/N ratio of 70dB. (3) Noise referred to signal input, with $E_C = \pm 5\text{V}$, is 60 μVrms , typ. (4) Bandwidth is DC to 20kHz, -3dB , independent of gain.

FIGURE 7. Voltage-Controlled Amplifier.

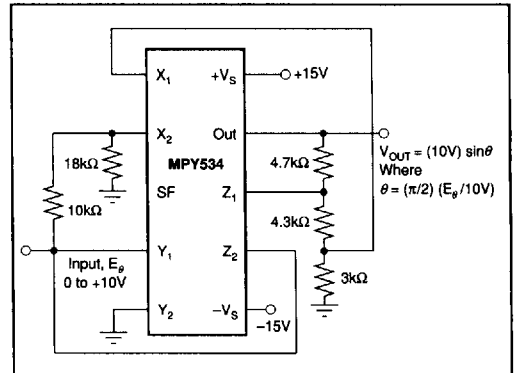

FIGURE 8. Sine-Function Generator.

MPY534

SPECIAL FUNCTIONS

For Immediate Assistance, Contact Your Local Salesperson

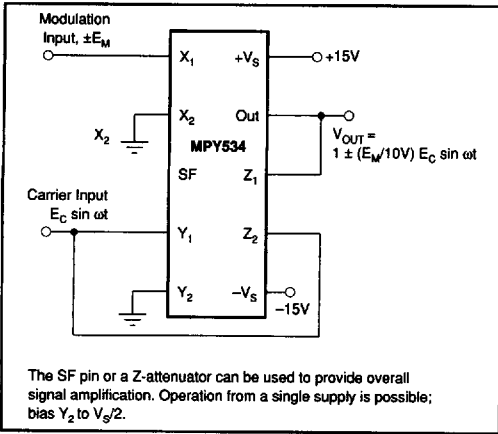

FIGURE 9. Linear AM Modulator.

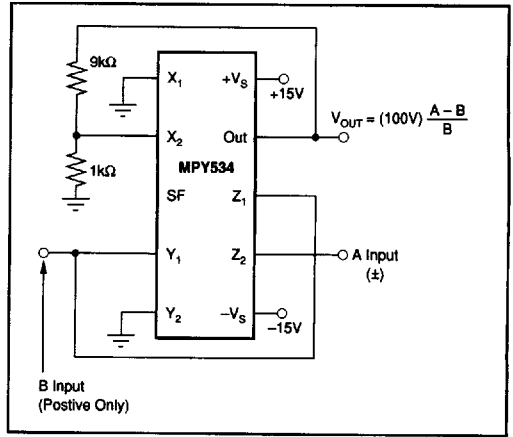

FIGURE 10. Percentage Computer.

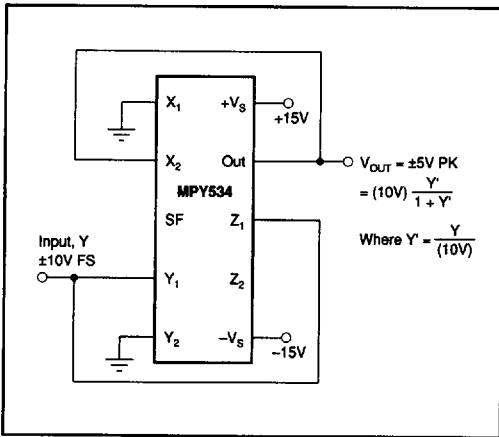

FIGURE 11. Bridge-Linearization Function.

The information provided herein is believed to be reliable; however, BURR-BROWN assumes no responsibility for inaccuracies or omissions. BURR-BROWN assumes no responsibility for the use of this information, and all use of such information shall be entirely at the user's own risk. Prices and specifications are subject to change without notice. No patent rights or licenses to any of the circuits described herein are implied or granted to any third party. BURR-BROWN does not authorize or warrant any BURR-BROWN product for use in life support devices and/or systems.