

Standard Products

ARX4418 & ARX4417 Variable Amplitude Transceiver for MACAIR (A3818, A4905, A5232, A5690), MIL-STD-1553 & SAE-AS15531

www.aeroflex.com/Avionics

March 31, 2005



FEATURES

- ARX4418 Transceiver meets Macair (A3818, A4905, A5232 and A5690) & MIL-STD-1553A/B
- ARX4417 Transceiver meets MIL-STD-1553 and SAE-AS15531
- Bipolar supply $\pm 15V$ to $\pm 12V$, Logic supply +5VDC
- Variable TX amplitude
- Variable receiver threshold capability
- Monolithic construction
- Voltage source output for higher bus drive power
- Designed for commercial, industrial and aerospace applications
- MIL-PRF-38534 compliant devices available
- Aeroflex-Plainview is a Class H & K MIL-PRF-38534 manufacturer
- DESC SMD 5962-9208503

GENERAL DESCRIPTION

The Aeroflex Plainview transceiver model ARX4418 and is a new generation monolithic transceiver which provide full compliance with Macair and MIL-STD-1553 data bus requirements while providing variable amplitude control.

The model ARX4418 and ARX4417 performs the front-end analog function of inputting and outputting data through a transformer to a MIL-STD-1553 or Macair data bus.

The ARX4418 can be considered a "Universal" Transceiver in that it is compatible with Macair (A-3818, A-4905, A-5232 and A-5690), MIL-STD-1553A/B and SAE-AS1553. The ARX4417 is compatible with MIL-STD-1553A/B and SAE-AS15531.

Design of these transceivers reflects particular attention to active filter performance. This results in low bit and word error rate with superior waveform purity and minimal zero crossover distortion. The ARX4418 active filter design has additional high frequency roll-off to provide the required Macair low harmonic distortion waveform without increasing the pulse delay characteristics significantly.

Efficient transmitter electrical and thermal design provides low internal power dissipation and heat rise at high and low duty cycles. An optional receiver input threshold adjustment can be accomplished by the use of the "External Threshold" terminals or by the use of the "Set Internal Threshold" terminals. Variable amplitude is adjusted with 0–10 VDC on the control pin.

TRANSMITTER

The Transmitter section accepts bi-phase TTL data at the input and when coupled to the data bus with a 1:1 transformer the data bus signal produced is 7.0 Volts minimum P-P at point A-A' (See Figure 5). When both DATA and $\overline{\text{DATA}}$ inputs are held low or high, the transmitter output becomes a high impedance and is "removed" from the line. In addition, an overriding "INHIBIT" input provides for the removal of the transmitter output from the line. A logic "1" applied to the "INHIBIT" takes priority over the condition of the data inputs and disables the transmitter (See Transmitter Logic Waveforms - Figure 1).

The transmitter utilizes an active filter to suppress harmonics above 1 MHz to meet Macair specifications A-3818, A-4905, A-5232 and A-5690. The transmitter may be safely operated for an indefinite period at 100% duty cycle into a data bus short circuit.

The transceiver utilizes an active filter to suppress harmonics above 1MHz. The Transmitter may be safely operated at 100% duty cycle for an indefinite period into a short circuited 1553 bus.

RECEIVER

The Receiver section accepts bi-phase differential data at the input and produces two TTL signals at the output. The outputs are DATA and $\overline{\text{DATA}}$, and represent positive and negative excursions of the input beyond a pre-determined threshold (See Receiver Logic Waveforms - Figure 2).

The internal threshold is nominally set to detect data bus signals exceeding 1.05 Vp-p and reject signals less than 0.6 Vp-p when used with a 1:1 turns ratio transformer (See Figure 5 for transformer data and typical connection). This threshold setting can be held by grounding the appropriate pins or modified with the use of external resistors.

A low level at the "STROBE" input inhibits the DATA and $\overline{\text{DATA}}$ outputs. If unused, a 2K Ohm pull-up to +5VDC is recommended.

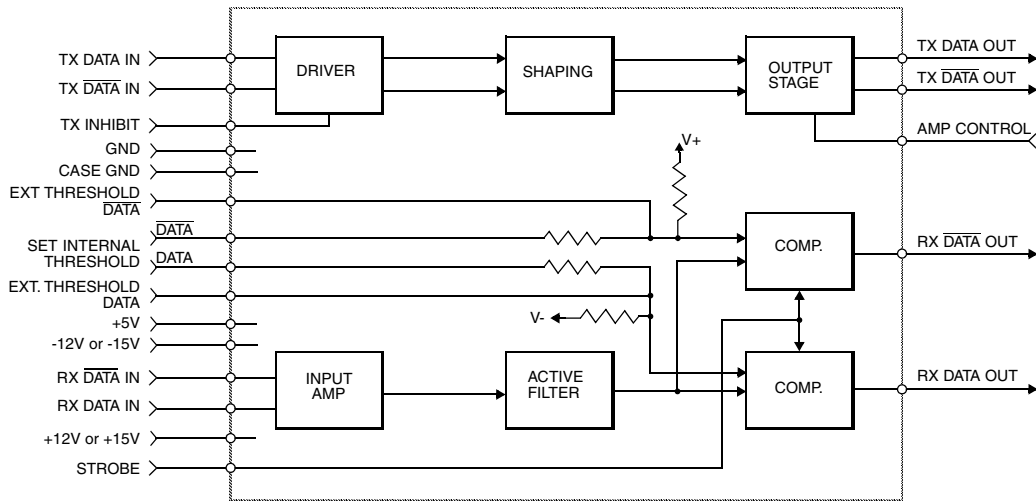

BLOCK DIAGRAM (WITHOUT TRANSFORMER)

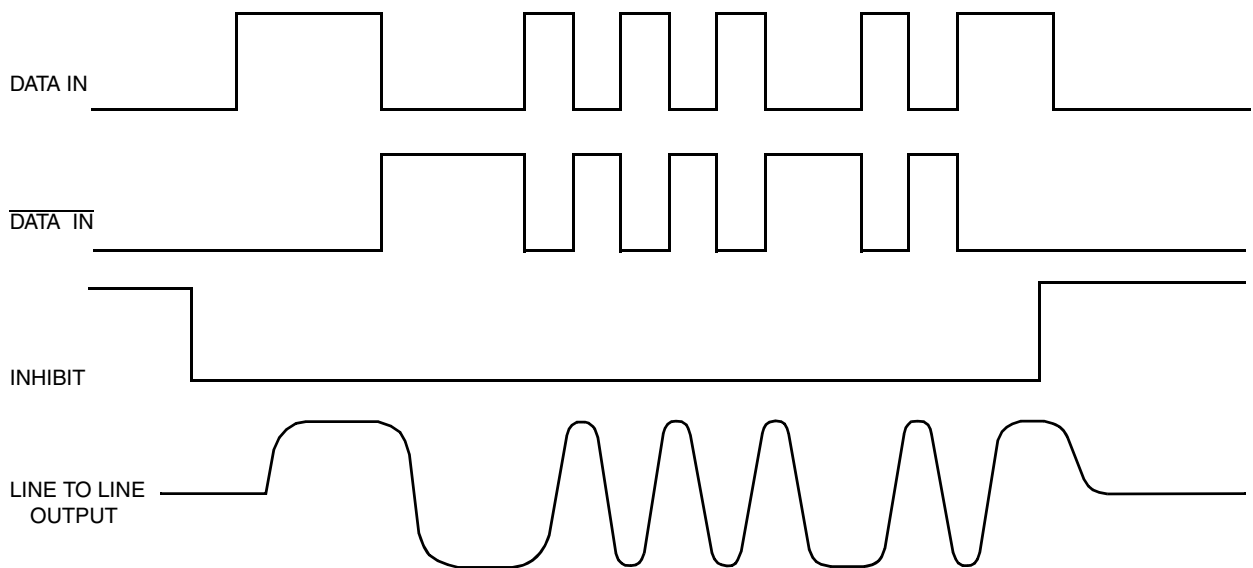

- Notes:
1. Line to line waveforms illustrate Macair signals, MIL-STD-1553 signals are trapezoidal.
 2. DATA and $\overline{\text{DATA}}$ inputs must be complementary waveforms or 50% duty cycle average, with no delays between them.
 3. DATA and $\overline{\text{DATA}}$ must be in the same state during off time (both high or low).

FIGURE 1 – TRANSMITTER LOGIC WAVEFORMS IDEALIZED

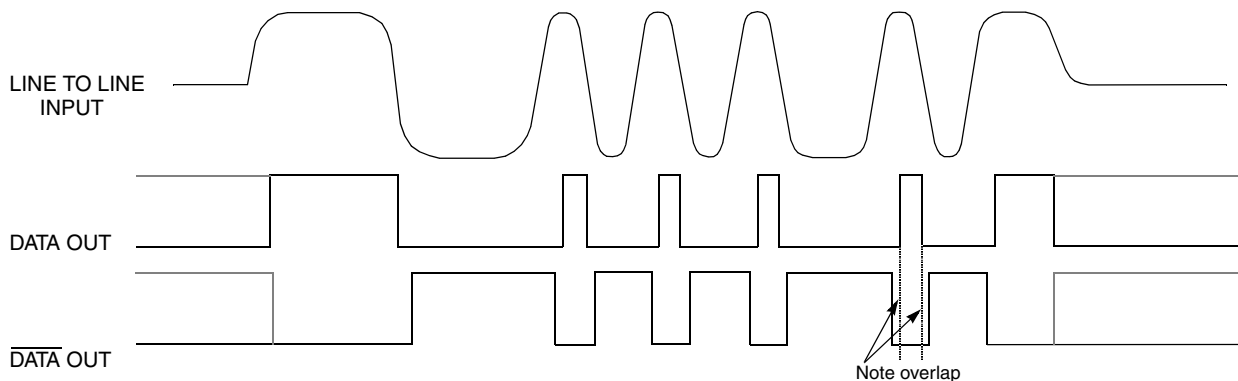

Note: Waveforms shown are for normally low devices. For normally high receiver output level devices, the receiver outputs are swapped as shown by the dashed lines

FIGURE 2 – RECEIVER LOGIC WAVEFORMS IDEALIZED

ABSOLUTE MAXIMUM RATINGS

Operating Case Temperature	-55°C to +125°C	
Storage Case Temperature	-65°C to +150°C	
Power Supply Voltages	±15VDC to ±18VDC	+5VDC to +7VDC
Logic Input Voltage	-0.3 V to +5.5 V	
Receiver Differential Input	±40 V	
Receiver Input Voltage (Common Mode)	±10V	
Driver Peak Output Current	300 mA	
Total Package Power Dissipation over the Full Operating Case Temperature Range	2.4 Watts	
Power Dissipation for hottest die, (100% duty cycle)	600 mW	
Maximum junction to case temperature rise for the hottest device (100 % duty cycle)	36°C	
Junction-Case, Thermal Resistance for hottest device	60°C/W	

ELECTRICAL CHARACTERISTICS – TRANSMITTER SECTION

INPUT CHARACTERISTICS, TX DATA IN OR TX DATA IN

Parameter	Condition	Symbol	Min	Typ	Max	Unit
"0" Input Current	$V_{IN} = 0.4V$	I_{ILD}	-	-0.2	-0.4	mA
"1" Input Current	$V_{IN} = 2.7V$	I_{IHD}	-	1	40	μA
"0" Input Voltage	-	V_{ILD}	-	-	0.7	V
"1" Input Voltage	-	V_{IHD}	2.0	-	-	V

INHIBIT CHARACTERISTICS

"0" Input Current	$V_{IN} = 0.4V$	I_{ILI}	-	-0.2	-0.4	mA
"1" Input Current	$V_{IN} = 2.7V$	I_{IHI}	-	1.0	40	μA
"0" Input Voltage	-	V_{ILI}	-	-	0.7	V
"1" Input Voltage	-	V_{IHI}	2	-	-	V
Delay from TX inhibit, (0→1) to inhibited output	Note 1	t_{DXOFF}	-	400	500	nS
Delay from TX inhibit, (1→0) to active output	Note 1	t_{DXON}	-	400	500	nS
Differential Output Noise, inhibit mode	-	V_{NOI}	-	0.8	10	mVp-p
Differential Output Impedance (inhibited)	Note 2	Z_{OI}	2K	-	-	Ω

OUTPUT CHARACTERISTICS

Differential output level at point B-B' Figure 5, $V_{cont} = 10 V_{dc}$, See Figure 6 for control voltage versus output level	$R_L = 140 \Omega$	V_O	28	30	36	V p-p
Rise and fall times (10% to 90% of p-p output)	-	t_R	200	250	300	nS
Output offset at point A-A' on Figure 5, 2.5 μS after midpoint crossing of the parity bit of the last word of a 660 μS message	$R_L = 35 \Omega$	V_{OS}	-	-	±90	mV peak
Delay from 50% point of TX DATA or TX DATA input to zero crossing of differential signal. (Note 1)	ARX4418	t_{DTX}	-	330	450	nS
	ARX4417		-	240	360	nS

ELECTRICAL CHARACTERISTICS – RECEIVER SECTION

Parameter	Condition	Symbol	Min	Typ	Max	Unit
Differential Input Impedance	f = 1MHz	Z _{IN}	10K	-	-	Ω
Differential Input Voltage Range	-	V _{IDR}	-	-	40	V _{p-p}
Input Common Mode Voltage Range	Note 1	V _{ICR}	10	-	-	V _{p-p}
Common Mode Rejection Ratio	Note 1	CMRR	40	-	-	dB

STROBE CHARACTERISTICS (LOGIC "0" INHIBITS OUTPUT)

"0" Input Current	V _S = 0.4V	I _{IL}	-	-0.2	-0.4	mA
"1" Input Current	V _S = 2.7V	I _{IH}	-	1	+40	μA
"0" Input Voltage	-	V _{IL}	-	-	0.7	V
"1" Input Voltage	-	V _{IH}	2.0	-	-	V
Strobe Delay (Turn-on or Turn-off)	Note 1	t _{SD}	-	-	150	nS

THRESHOLD CHARACTERISTICS (SINEWAVE INPUT)

Internal Threshold Voltage (referred to the bus) pins 6 and 11 grounded	100KHz - 1MHz	V _{TH}	0.60	0.8	1.05	V p-p
--	---------------	-----------------	------	-----	------	-------

OUTPUT CHARACTERISTICS, RX DATA AND RX DATA

"1" State	I _{OH} = -0.4 mA	V _{OH}	2.5	3.6	-	V
"0" State	I _{OL} = 4 mA	V _{OL}	-	0.35	0.5	V
Delay (average), from differential input zero crossings to RX DATA and RX DATA output 50% points	Note 1	t _{DRX}	-	300	450	nS

POWER DATA

POWER SUPPLY CURRENTS (POWER SUPPLIES SET AT +15V, -15V, +5V)

Transmitter Standby		I _{CC} I _{EE} I _L		30 50 25	60 75 35	mA
25% duty cycle		I _{CC} I _{EE} I _L		50 70 25	85 105 35	
50% duty cycle		I _{CC} I _{EE} I _L		75 45 25	110 130 35	
100% duty cycle		I _{CC} I _{EE} I _L		120 140 25	160 180 35	

RECOMMENDED POWER SUPPLY VOLTAGE RANGE

+V	+11.4 Volts to +15.75 Volts
-V	-11.4 Volts to -15.75 Volts
Logic	+4.5 Volts to +5.5 Volts

Notes: 1. Characteristics guaranteed by design, not production tested.

2. Power on or off, measured from 75KHz to 1MHz at point A-A' and transformer self impedance of 3KΩ minimum at 1MHz.

3. Specifications apply over the temperature range of -55°C to +125°C (Case Temperature) unless otherwise noted.

4. All typical values are measured at +25°C.

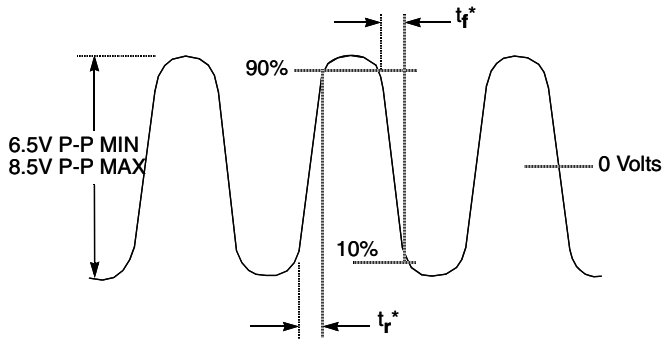

* Rise and fall times measured at point A-A' in Figure 5

FIGURE 3 – TRANSMITTER (TX) OUTPUT WAVEFORM

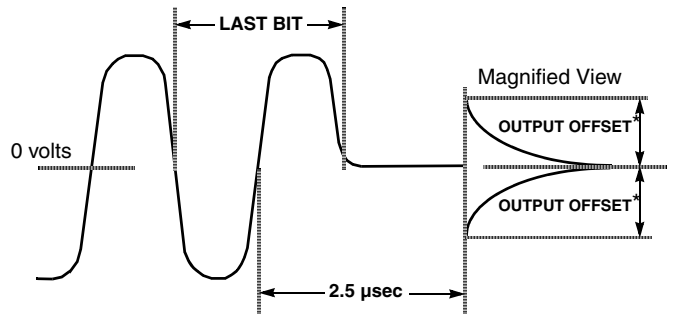

*Offset measured at point A-A' in Figure 5

FIGURE 4 – TRANSMITTER (TX) OUTPUT OFFSET

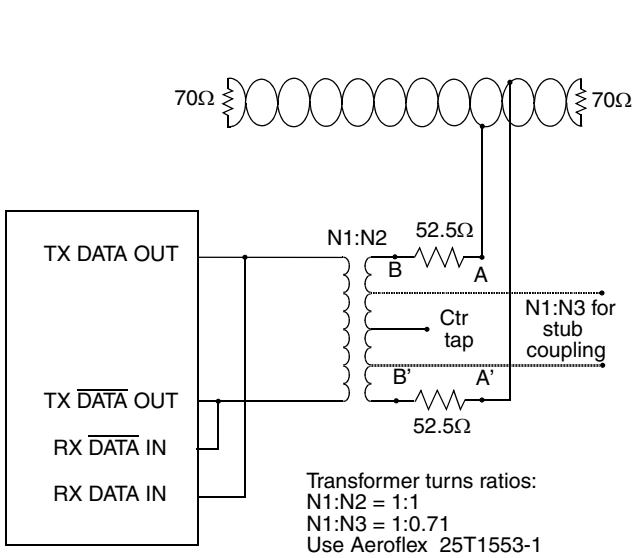

FIGURE 5 – TYPICAL TRANSFORMER CONNECTION

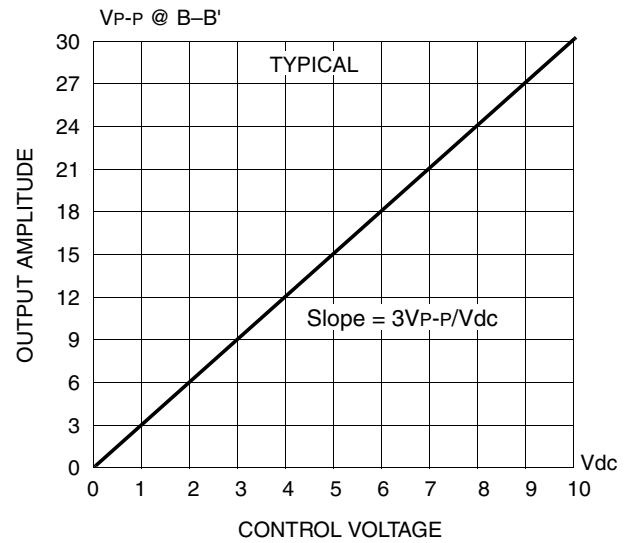

FIGURE 6 – TRANSMITTER (TX) OUTPUT AMPLITUDE vs. CONTROL VOLTAGE

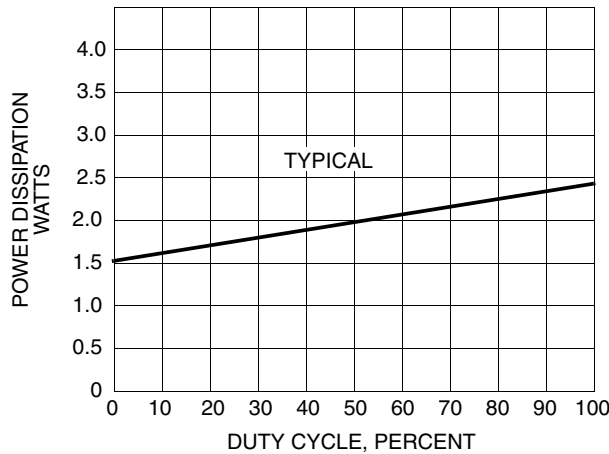

FIGURE 7 – TYPICAL POWER DISSIPATION vs. DUTY CYCLE

CONFIGURATIONS AND ORDERING INFORMATION *

Model No.	DSCC No.	Receiver Data level	Configuration	Specs.
ARX4418	5962-9208503HXX	Normally Low	Plug In	1553 & Macair
ARX4418-FP	5962-9208503HYX		Flat Pack	1553 & Macair
ARX4418-LPFP	-		Low Profile Flat Pack	1553 & Macair
ARX4417	-	Normally High	Plug In	1553
ARX4417-FP			Flat Pack	
ARX4417-LPFP			Low Profile Flat Pack	

* Not for new designs. See ACT4418N Series.

PACKAGE CONFIGURATION OUTLINE

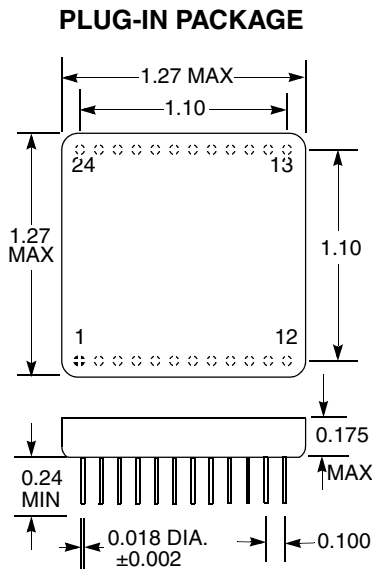

- Pin Function**
- 1 TX DATA OUT
 - 2 TX DATA OUT
 - 3 TX GND (+5)
 - 4 +15V (TX)
 - 5 EXT. DATA THRES
 - 6 INT. DATA THRES
 - 7 RX DATA OUT
 - 8 STROBE
 - 9 RX GND (+5V)
 - 10 RXDATA OUT
 - 11 INT. DATA THRES
 - 12 EXT. DATA THRES
 - 13 +15V (RX)
 - 14 AMP CONTROL
 - 15 RX DATA IN
 - 16 RX DATA IN
 - 17 GND
 - 18 CASE GND
 - 19 -15V (RX)
 - 20 +5V
 - 21 TX INHIBIT
 - 22 TX DATA IN
 - 23 TX DATA IN
 - 24 -15V(TX)

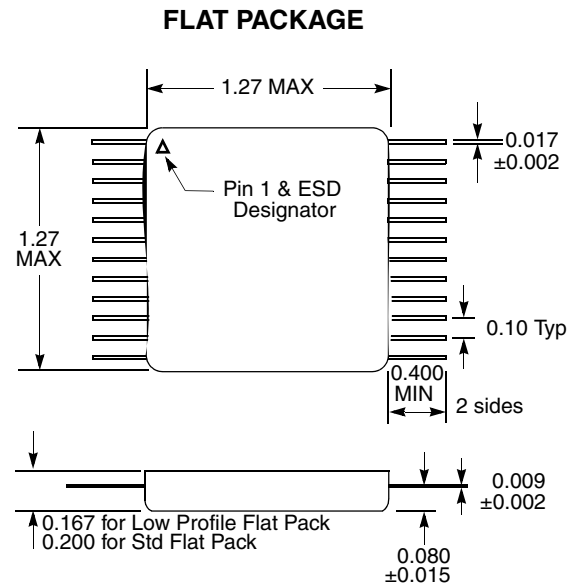

Notes

1. Dimensions shown are in inches.
2. Pins are equally spaced at 0.100±0.002 tolerance, non-cumulative, each row.

PLAINVIEW, NEW YORK
Toll Free: 800-THE-1553
Fax: 516-694-6715

INTERNATIONAL
Tel: 805-778-9229
Fax: 805-778-1980

NORTHEAST
Tel: 603-888-3975
Fax: 603-888-4585

SE AND MID-ATLANTIC
Tel: 321-951-4164
Fax: 321-951-4254

WEST COAST
Tel: 949-362-2260
Fax: 949-362-2266

CENTRAL
Tel: 719-594-8017
Fax: 719-594-8468

www.aeroflex.com info-ams@aeroflex.com



Aeroflex Microelectronic Solutions reserves the right to change at any time without notice the specifications, design, function, or form of its products described herein. All parameters must be validated for each customer's application by engineering. No liability is assumed as a result of use of this product. No patent licenses are implied.



Our passion for performance is defined by three attributes represented by these three icons: solution-minded, performance-driven and customer-focused