

# Technical Data Sheet

## 115.2Kbit/s Infrared Transceiver

---

### TM3204/TR2

#### Features

- Excellent Fluorescent Noise Immunity and Very High EMI Immunity
- Wide Operating Voltage Range from 2.4 to 5.0 Volts
- Independent IrED Operating Voltage Range from 2.0 to 6 Volts
- Ultra Small Surface Mount Package:
  - L 8.0mm \* W 3.0mm \* H 2.15mm
- Data Rate :2.4k ~ 115.2kbit/s
- Operating Temperature Range : -25°C to 85°C
- LED Drive Current : 60 mA Typical
- Low Shutdown Current :0.1  $\mu$  A Typical
- Few External Components Required
- Pb-free
- The product itself will remain within RoHS compliant version.



#### Descriptions

The TM3204/TR2 is a new generation of low-cost infrared transceiver modules. The module is in ultra-small surface mount package. Although the operating voltage can range from 2.4 to 5.0 Volts, the LED drive current is internally compensated to a constant 60 mA to assure that link distances meet the low power standard of IrDA 1.3 physical layer specification.

#### Applications

- PDA
- Digital Still and Video Cameras
- Handheld Battery Operated Products, ex: Handheld Printers
- Electronic wallet
- Mobile Telecommunication

**Package Dimensions**

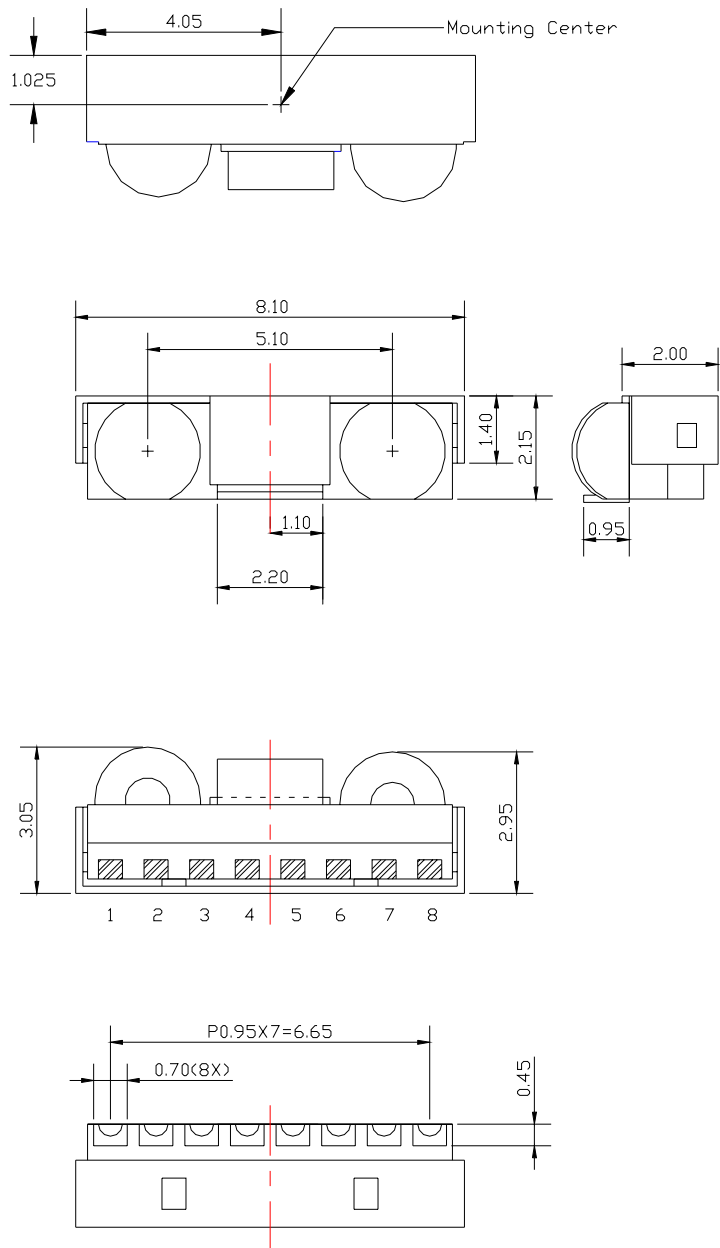

Unit : mm

Tolerance:  $\pm 0.2$  mm

**Device Selection Guide**

Mode	Standard		$\lambda_p$ (nm)	Operating Voltage (Vcc)	Data Rate (kbps)
	Link Distance	Angle $2\theta 1/2$			
TM3204/TR2	>50cm	+/-15~+/-30	850~900	2.4~5.0 Volts	2.4~115.2

**Pin Descriptions**

Pin	Symbol	Function	Description	I/O	Active
1	NC	No Connect			
2	NC	No Connect			
3	Vcc	Supply Voltage	Supply Voltage from 2.4 to 5.0 Volts. *Note 1		
4	GND	Ground	Connect to system ground		
5	SD	Shut Down	Must be driven either high or low. *Note 2	I	High
6	RXD	Receiver Data Output	Output is a low pulse when a light pulse is seen. *Note 3	O	Low
7	TXD	Transmitter Data Input	Logic High turn on the IrED. *Note 4	I	High
8	V <sub>LEDA</sub>	IrED Supply Voltage	IrED Supply Voltage from 2.0 to 6 Volts.		

Note 1: Receives power supply from 2.4 to 5.0 Volts. This pin provides power for the receiver and transmitter drive section. Power supply noise in 100KHz to 2MHz range must have a dv/dt of less than 50mV/us in receive mode.

Note 2: Asserting this pin above 1.4V causes the device to shut down, disabling transmitter and tri-stating the receiver output; however, it must be driven above V<sub>dd</sub>-1.3V for shutdown current consumption to be less 1uA.

Note 3: Normally high goes low for duration of receive pulse. Output is a CMOS driver providing rail to rail operation. RXD may go low continuously if the DC ambient exceeds input capacity. During shutdown RXD output tri-states with a weak (500K) pull up.

Note 4: Asserting this pin above 1.4V turns on transmitter. This input is gated by the shutdown function and AC coupled. Maximum transmit pulse width is ~50usec. Input has 500K pull down which is active even during shutdown.



## TM3204/TR2

**Absolute Maximum Ratings** ( $T_a=25^{\circ}\text{C}$ ) reference point Pin GND unless otherwise noted.

Typical values are for DESIGN AID ONLY, not guaranteed nor subject to production testing.

Parameters	Test Conditions	Symbol	Min.	Typ.	Max.	Unit
Supply Voltage	All States	V <sub>CC</sub>	-0.5		7	V
IrED Supply Voltage	SD=0, TXD=V <sub>CC</sub>	V <sub>LEDA</sub>	-0.5		V <sub>CC</sub> +4	V
Receiver Data Output	All States	RXD	-0.5		V <sub>CC</sub> +0.5	V
Transmitter Data Input	All States	TXD	-0.5		V <sub>CC</sub> +0.5	V
Shut Down	All States	SD	-0.5		V <sub>CC</sub> +0.5	V
Operating Temperature Range		T <sub>amb</sub>	-25		+85	°C
Storage Temperature Range		T <sub>stg</sub>	-40		100	°C
Soldering Temperature	See Recommended Solder Profile			-	245	°C

### Recommended Operating Conditions

Parameters	Test Conditions	Symbol	Min.	Typ.	Max.	Unit
Operating Temperature Range		T <sub>amb</sub>	-25		+85	°C
Supply Voltage	V <sub>CC</sub> to GND	V <sub>CC</sub>	2.4		5.0	V
TXD,SD Input Threshold	V <sub>CC</sub> =2.4 to 5.0V		2.4		5.0	V
Receiver Data Rate			2.4		115.2	kbps

### Electrical Characteristics

T<sub>amb</sub>=25°C, V<sub>CC</sub>=2.4V to 5.0V unless otherwise noted.

Typical values are for DESIGN AID ONLY, not guaranteed nor subject to production testing.

Parameters	Test Conditions / Pins	Symbol	Min.	Typ.	Max.	Unit
<b>Transceiver</b>						
Supply Voltage	V <sub>CC</sub> to GND	V <sub>CC</sub>	2.4		5.0	V
Supply Current Pin V <sub>CC</sub> (No signal)	V <sub>CC</sub> =3.6V	I <sub>CC</sub>		110		uA
Shut Down Current Pin SD	SD=V <sub>CC</sub> , V <sub>CC</sub> =2.4 to 5.0V	I <sub>SD</sub>		0.01	1.0	uA
Transmit Receiver Latency		T <sub>TRL</sub>		50	100	uA
Transceiver Power on Latency		T <sub>PON</sub>		100	150	us



## TM3204/TR2

### Opto-electronic Characteristics

Tamb=25°C, Vcc=2.4V to 5.0V unless otherwise noted.

Typical values are for DESIGN AID ONLY, not guaranteed nor subject to production testing.

Parameters	Test Conditions	Symbol	Min.	Typ.	Max.	Unit
<b>Receiver</b>						
Minimum Detection Threshold Irradiance	SIR Mode, Vcc=3.6V	Ee	-	-	4	uW/cm <sup>2</sup>
	SIR Mode, Vcc=2.7V	Ee	-	-	10	uW/m <sup>2</sup>
Maximum Detection Threshold Irradiance	SIR Mode, Vcc=3.6V	Ee	-	500		uW/cm <sup>2</sup>
	SIR Mode, Vcc=2.7V	Ee	-	1000		uW/cm <sup>2</sup>
Logic LOW Receiver Input Irradiance		Ee			0.4	uW/cm <sup>2</sup>
Output Voltage -Active	I <sub>OH</sub> =-200 μA, EI ≤ 0.3 uW/cm <sup>2</sup>	V <sub>OH</sub>	Vcc-0.2		Vcc	V
	I <sub>OL</sub> =200 μA,	V <sub>OL</sub>	0		0.4	V
Rise/Fall Time-RXD	Vcc=5.0V, C=15pF	t <sub>r</sub> /t <sub>f</sub> (RXD)		40		ns
	Vcc=2.4V, C=15pF	t <sub>r</sub> /t <sub>f</sub> (RXD)		60		ns
<b>Transmitter</b>						
IrED Operating Current	Vcc=2.4 to 5.0V	I <sub>IrED</sub>		60	-	mA
Logic LOW Transmitter Input Voltage		V <sub>IL</sub>	0		1/3Vcc	V
Logic HIGH Transmitter Input Voltage		V <sub>IH</sub>	2/3Vcc		Vcc	V
Output Radiant Intensity	Vcc=2.7V	I <sub>e</sub>	4	5		mW/sr
	TXD Logic LOW Level	I <sub>e</sub>			0.04	mW/sr
Angle of Half Intensity		2 θ <sub>1/2</sub>	30			°
Peak Wavelength of Emission		λ <sub>p</sub>	850	870	900	nm
Half-Width of Emission Spectrum		Δλ		40		nm
Average IrED Current		I <sub>IrED</sub> (DC)		11.25		mA
Repetitive Pulsed IrED Current	t<50 μs, t <sub>on</sub> <20%	I <sub>IrED</sub> (RP)		60		mA
Optical Rise/Fall Time,		t <sub>r</sub> /t <sub>f</sub>		180	600	ns
Optical Overshoot					25	%

**Recommended Circuit Diagram**

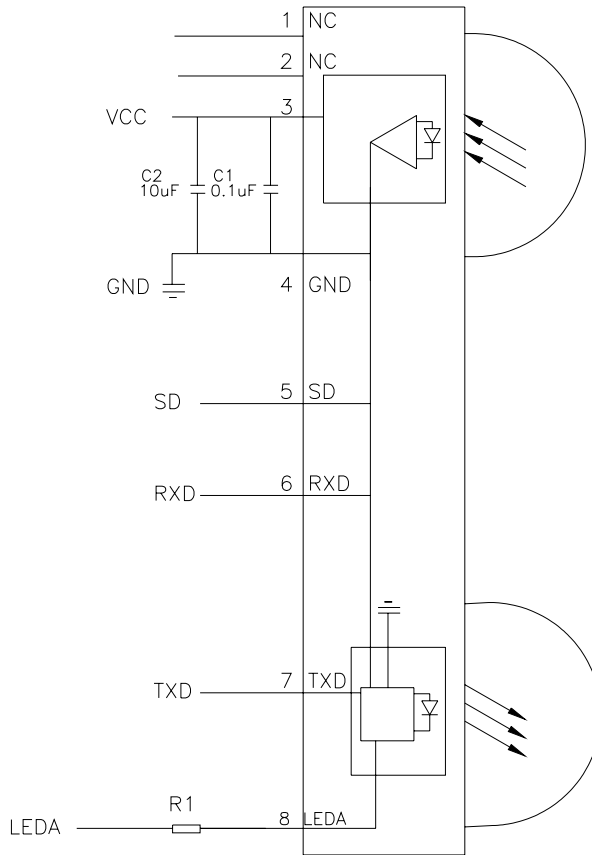

Note: Outlined components are optional depending on the quality of the power supply.

Component	Recommended Value
C1	0.1uF (Ceramic). It must be placed within 0.7cm of the TM3204/TR2
C2	10uF (Electrolytic). It must be placed within 15cm of the TM3204/TR2
R1	Recommended R1=10Ω, 16Ω, 22Ω, 30Ω 1/4 Watt at Vcc=2.4V, 2.7V, 3.0V, 3.6V. Resistor must have a positive temperature coefficient of 0.47% per degree C

**Recommended SMD Pad Layout**

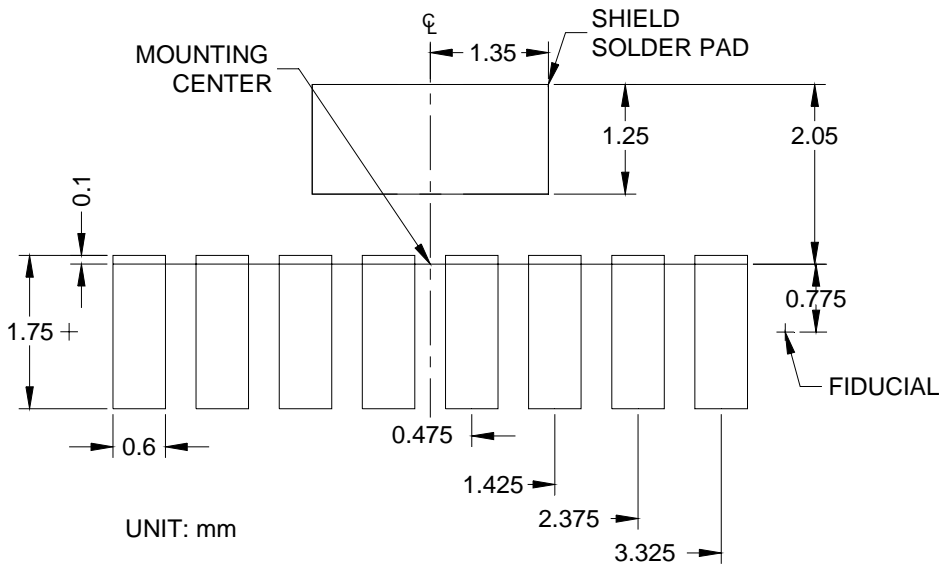

**Recommended Solder Profile**

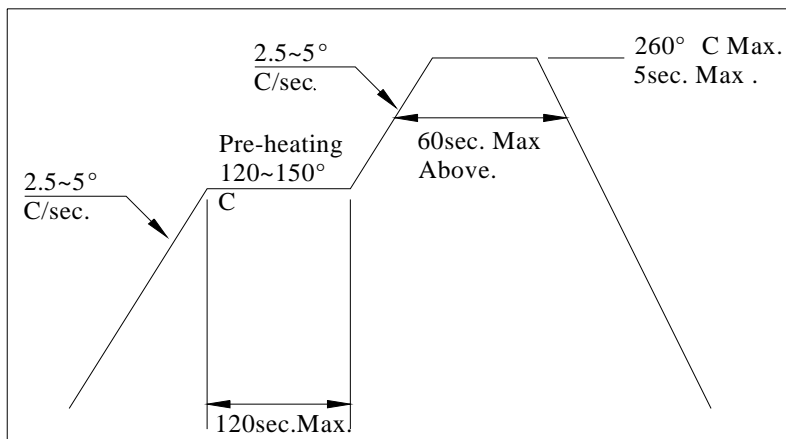

**Notice:**

- (1) Reflow soldering should not be done more than two times.
- (2) When soldering, do not put stress on the IrDA devices during heating.
- (3) After soldering, do not warp the circuit board.

**Taping and Packing Information**

**Shape of Reel and Dimensions**

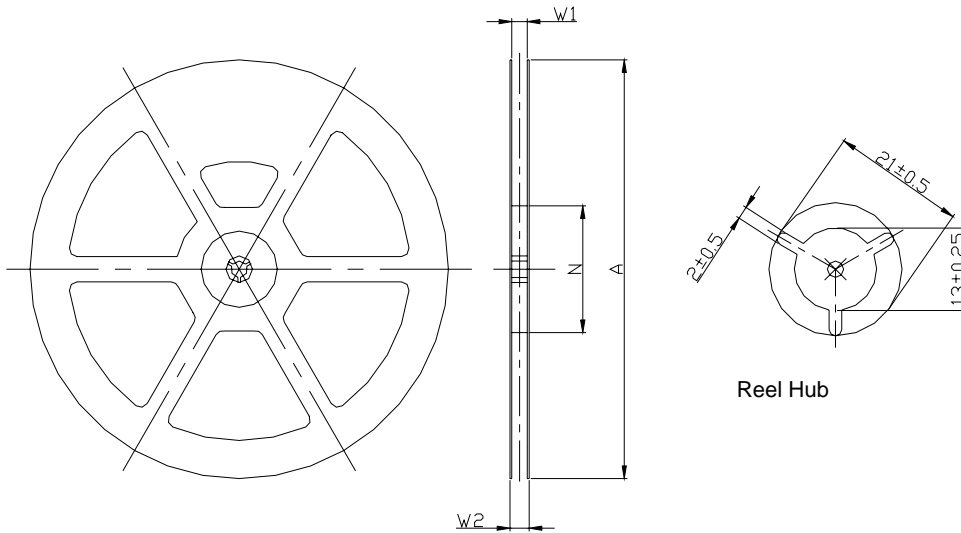

Version	Tape Width	A	N	W1	W2max
C	16	330±1	100±1.5	18±2	22

**Tape Dimensions**

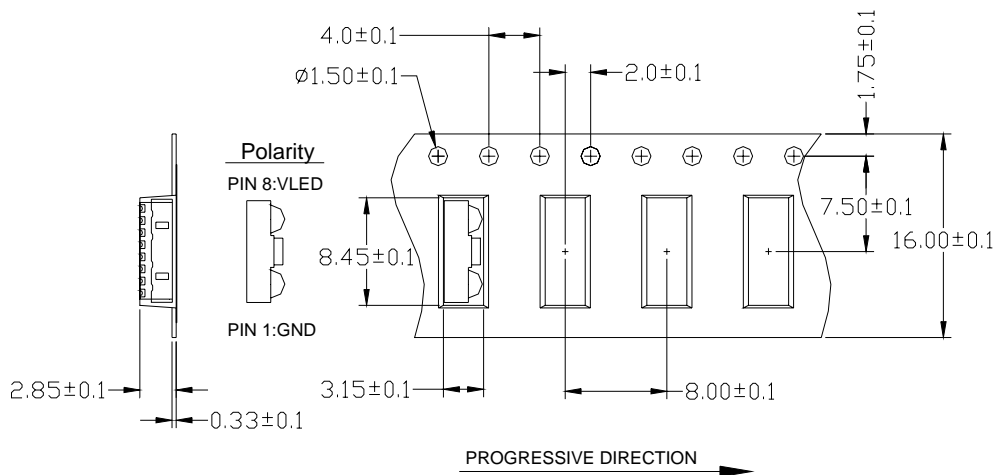

Leader and Trailer

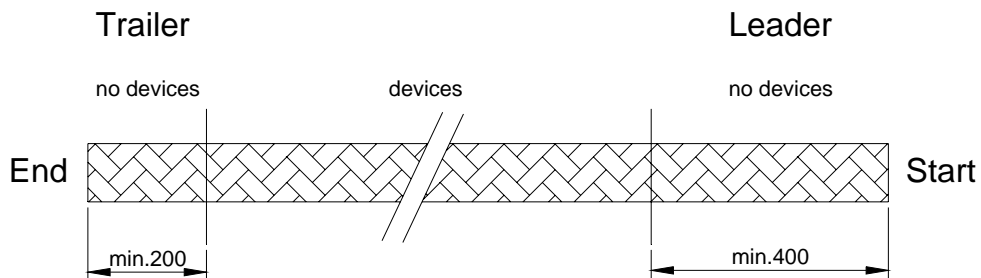

Quantity

TM3204/TR2 2500 pcs. per reel

Cover Tape Peel Strength

According to IEC 286

0.1 to 1.3N

300±10%mm/min

165° -180° peel angle

Damp Proof Packing.

The reel is packed in a damp proof aluminum bag to protect the devices from absorbing moisture during transportation and storage.

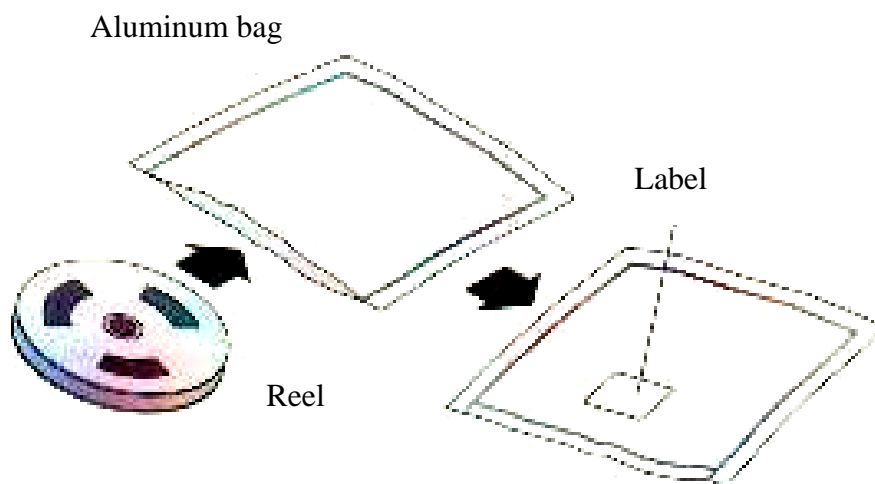

### Recommended Method of Storage

Dry box storage is recommended as soon as the aluminum bag has been opened to prevent moisture absorption. The following conditions should be observed, if dry boxes are not available:

- Storage temperature 10°C to 30°C
- Storage humidity  $\leq 60\%RH$  max.

After more than 72hours under these conditions moisture content will be too high for reflow soldering.

In case of moisture absorption, the devices will recover to the former condition by drying under the following condition:

192 hours at 40°C+5°C/-0°C and 5% RH(dry air/nitrogen) or

96 hours at 60°C+5°C and <5% RH for all device containers or

24 hours at 125°C+5°C not suitable for reel or tubes.

### ESD Precaution

Proper storage and handling procedures should be followed to prevent ESD damage to the devices especially when they are removed from the Antistatic Shielding Bag. Electro-Static Sensitive Devices warning labels are on the packing.

**EVERLIGHT ELECTRONICS CO., LTD.**

Office: No 25, Lane 76, Sec 3, Chung Yang Rd,  
Tucheng, Taipei 236, Taiwan, R.O.C

Tel: 886-2-2267-2000, 2267-9936

Fax: 886-2267-6244, 2267-6189, 2267-6306

<http://www.everlight.com>