

# ICM7226/D, ICM7226/W

## 8-Digit Multi-Function Frequency Counter/Timer



ICM7226/D, ICM7226/W

### GENERAL DESCRIPTION

The ICM7226 is a fully integrated Universal Counter and LED display driver. It combines a high frequency oscillator, a decade timebase counter, an 8 decade data counter and latches, a 7 segment decoder, digit multiplexer, and segment and digit drivers which can directly drive large LED displays. The counter inputs accept a maximum frequency of 5 MHz in **frequency** and **unit counter** modes and 2 MHz in the other modes. Both inputs are digital inputs. In many applications, amplification and level shifting will be required to obtain proper digital signals for these inputs.

The ICM7226 can function as a frequency counter, period counter, frequency ratio ( $f_A/f_B$ ) counter, time interval counter or a totalizing counter. The devices require either a 10 MHz or 1 MHz crystal timebase, or if desired an external timebase can also be used. For **period** and **time interval**, the 10 MHz timebase gives a 0.1  $\mu$ s resolution. In **period average** and **time interval average**, the resolution can be in the nanosecond range. In the **frequency** mode, the user can select accumulation time of 10 ms, 100 ms, 1s and 10s. With a 10s accumulation time, the frequency can be displayed to a resolution of 0.1 Hz. There is a 0.2s interval between measurements in all ranges. Control signals are provided to enable gating and storing of prescaler data.

Leading zero blanking has been incorporated with frequency display in kHz and time in  $\mu$ s. The display is multiplexed at a 500 Hz rate with a 12.2% duty cycle for each digit. The ICM7226A is designed for common anode displays with typical peak segment currents of 25 mA, and the ICM7226B is designed for common cathode displays with typical segment currents of 12 mA. In the **display off** mode, both digit drivers & segment drivers are turned off, allowing the display to be used for other functions.

### ORDERING INFORMATION

Part Number	Temperature	Form
ICM7226A/D	+ 25°C	Dice
ICM7226B/D	+ 25°C	Dice
ICM7226A/W	+ 25°C	Wafer
ICM7226B/W	+ 25°C	Wafer

### FEATURES

- CMOS Design for Very Low Power
- Output Drivers Directly Drive Both Digits and Segments of Large 8 Digit LED Displays. Both Common Anode and Common Cathode Versions Are Available
- Measures Frequencies From DC to 5 MHz; Periods From 0.5  $\mu$ s to 10s
- Stable High Frequency Oscillator Uses Either 1 MHz or 10 MHz Crystal
- Control Signals Available for External Systems Operation
- Multiplexed BCD Outputs

### APPLICATIONS

- Frequency Counter
- Period Counter
- Unit Counter
- Frequency Ratio Counter
- Time Interval Counter

INTERSIL'S SOLE AND EXCLUSIVE WARRANTY OBLIGATION WITH RESPECT TO THIS PRODUCT SHALL BE THAT STATED IN THE WARRANTY ARTICLE OF THE CONDITION OF SALE. THE WARRANTY SHALL BE EXCLUSIVE AND SHALL BE IN LIEU OF ALL OTHER WARRANTIES, EXPRESS, IMPLIED OR STATUTORY, INCLUDING THE IMPLIED WARRANTIES OF MERCHANTABILITY AND FITNESS FOR A PARTICULAR USE.

NOTE: All typical values have been characterized but are not tested.

## ABSOLUTE MAXIMUM RATINGS

Maximum Supply Voltage ( $V_{DD}-V_{SS}$ )	6.5V
Maximum Digit Output Current	400 mA
Maximum Segment Output Current	60 mA
Voltage on any Input or Output Terminal (Note 1) .. ( $V_{SS} - 0.3V$ ) to ( $V_{DD} + 0.3V$ )	
Operating Temperature Range	+25°C
Storage Temperature Range	-55°C to +125°C

**NOTE:** Stresses above those listed under "Absolute Maximum Ratings" may cause permanent damage to the device. These are stress ratings only and functional operation of the device at these or any other conditions above those indicated in the operational sections of the specifications is not implied. Exposure to absolute maximum rating conditions for extended periods may affect device reliability.

**NOTE 1:** Destructive latching may occur if input signals are applied before the power supply is established or if inputs or outputs are forced to voltages exceeding  $V_{DD}$  or  $V_{SS}$  by 0.3V.

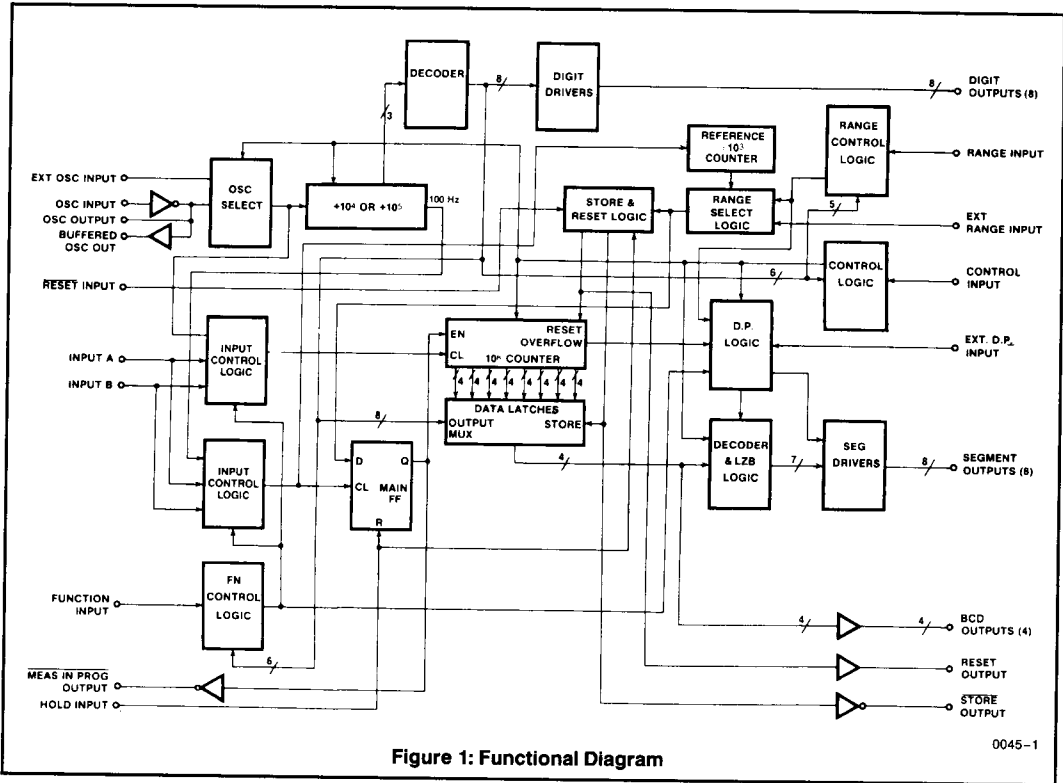

INTERSIL'S SOLE AND EXCLUSIVE WARRANTY OBLIGATION WITH RESPECT TO THIS PRODUCT SHALL BE THAT STATED IN THE WARRANTY ARTICLE OF THE CONDITION OF SALE. THE WARRANTY SHALL BE EXCLUSIVE AND SHALL BE IN LIEU OF ALL OTHER WARRANTIES, EXPRESS, IMPLIED OR STATUTORY, INCLUDING THE IMPLIED WARRANTIES OF MERCHANTABILITY AND FITNESS FOR A PARTICULAR USE.

NOTE: All typical values have been characterized but are not tested.

# ICM7226/D, ICM7226/W



ICM7226/D, ICM7226/W

## CHIP TOPOGRAPHIES

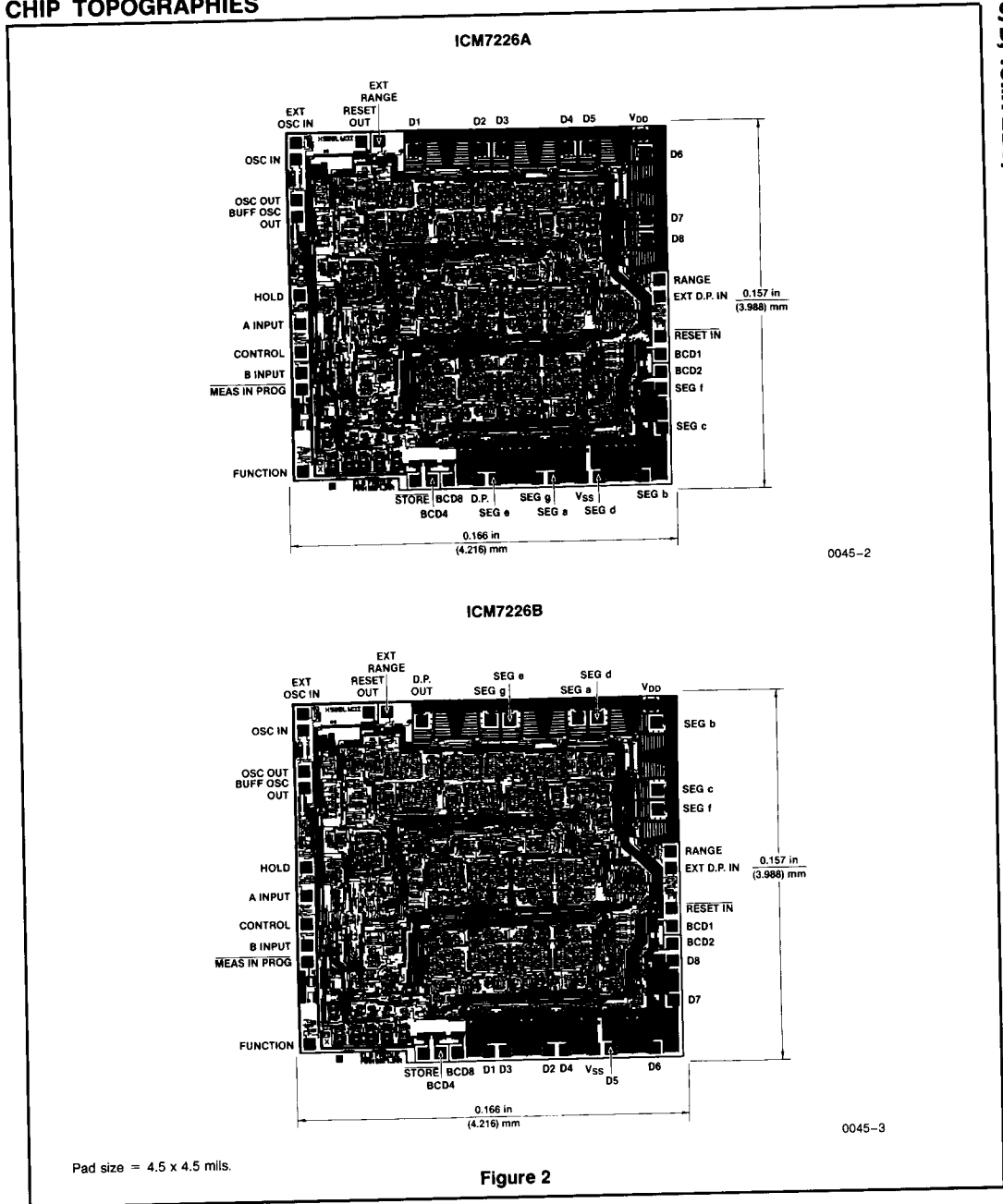

Figure 2

INTERMIL'S SOLE AND EXCLUSIVE WARRANTY OBLIGATION WITH RESPECT TO THIS PRODUCT SHALL BE THAT STATED IN THE WARRANTY ARTICLE OF THE CONDITION OF SALE. THE WARRANTY SHALL BE EXCLUSIVE AND SHALL BE IN LIEU OF ALL OTHER WARRANTIES, EXPRESS, IMPLIED OR STATUTORY, INCLUDING THE IMPLIED WARRANTIES OF MERCHANTABILITY AND FITNESS FOR A PARTICULAR USE.

NOTE: All typical values have been characterized but are not tested.

## ELECTRICAL CHARACTERISTICS

 $V_{DD} = 5.0V$ ,  $T_A = 25^\circ C$ , unless otherwise specified

Symbol	Parameter	Test Conditions	Min	Typ	Max	Units
$I_{DD}$	Operating Supply Current	Display Off Unused Inputs to $V_{SS}$		2	5	mA
$V_{SUPPLY}$	Supply Voltage Range $V_{DD}-V_{SS}$	Input A, Input B Frequency at $f_{MAX}$	4.75		6.0	V
$f_A$ (max)	Maximum Guaranteed Frequency Input A, Pin 40	$4.75V < V_{DD} < 6.0V$ Function = Frequency, Ratio, Unit Counter Function = Period, Time Interval	5 2.5	14		MHz
$f_B$ (max)	Maximum Frequency Input B, Pin 2	$4.75V < V_{DD} < 6.0V$	2.5			
	Minimum Separation Input A to Input B Time Interval Function	$4.75V < V_{DD} < 6.0V$	250			ns
$f_{osc}$	Osc. Freq. and Ext. Osc. Freq. (minimum Ext. Osc. Freq.)	$4.75V < V_{DD} < 6.0V$	5 (0.1)			MHz
$g_m$	Oscillator Transconductance	$V_{DD} = 4.75V$	2000			$\mu S$
$f_{mux}$	Multiplex Frequency	$f_{osc} = 5 MHz$		500		Hz
	Time Between Measurements	$f_{osc} = 5 MHz$		200		ms
$dV_{in}/dt$	Input Rate of Charge	Inputs A, B		15		$mV/\mu S$
$V_{IL}$	INPUT VOLTAGES PINS 2, 19, 33, 39, 40, 35 Input Low Voltage				1.0	V
$V_{IH}$	Input High Voltage		3.5			
$I_{ILK}$	PIN 2, 39, 40 INPUT LEAKAGE A, B				20	$\mu A$
$R_{IN}$	Input Resistance to $V_{DD}$ PINS 19, 33	$V_{IN} = V_{DD} - 1.0V$	100	400		k $\Omega$
$R_{IN}$	Input Resistance to $V_{SS}$ PIN 31	$V_{IN} = +1.0V$	50	100		
$I_{OL}$	Output Current PINS 3, 5, 6, 7, 17, 18, 32, 38	$V_{OL} = +0.4V$	400			$\mu A$
$I_{OH}$	PINS 5, 6, 7, 17, 18, 32	$V_{OH} = +2.4V$	100			$\mu A$
$I_{OH}$	PINS 3, 38	$V_{OH} = V_{DD} - 0.8V$	265			
$I_{OH}$	ICM7226A PINS 22, 23, 24, 26, 27, 28, 29, 30 DIGIT DRIVER High Output Current	$V_O = V_{DD} - 2.0V$	150	180		mA
$I_{OL}$	Low Output Current	$V_O = +1.0V$		-0.3		
$I_{OL}$	SEGMENT DRIVER PINS 8, 9, 10, 11, 13, 14, 15, 16 Low Output Current	$V_O = +1.5V$	25	35		mA
$I_{OH}$	High Output Current	$V_O = V_{DD} - 1.0V$		100		
$V_{IL}$	MULTIPLEX INPUTS PINS 1, 4, 20, 21 Input Low Voltage				0.8	V
$V_{IH}$	Input High Voltage		2.0			
$R_{IN}$	Input Resistance to $V_{SS}$	$V_{IN} = +1.0V$	50	100		

INTERSIL'S SOLE AND EXCLUSIVE WARRANTY OBLIGATION WITH RESPECT TO THIS PRODUCT SHALL BE THAT STATED IN THE WARRANTY ARTICLE OF THE CONDITION OF SALE. THE WARRANTY SHALL BE EXCLUSIVE AND SHALL BE IN LIEU OF ALL OTHER WARRANTIES, EXPRESS, IMPLIED OR STATUTORY, INCLUDING THE IMPLIED WARRANTIES OF MERCHANTABILITY AND FITNESS FOR A PARTICULAR USE.

NOTE: All typical values have been characterized but are not tested.