

MN4532B/MN4532BS

8-Bit Priority Encoder

■ Outline

The MN4532B/S is a 8-bit input priority encoder having active "H" priority inputs ($I_0 \sim I_7$), active "H" outputs ($O_0 \sim O_2$), an active "H" enable input (E_{in}), an active "H" output (E_{out}), and an active "H" group select output (GS).

Data is input to $I_0 \sim I_7$, and when the level of E_{in} is "H", the most significant "H" level input of the priority inputs ($I_0 \sim I_7$) is converted into a binary code and output to $O_0 \sim O_2$. The level of E_{out} becomes "H" when the levels of $I_0 \sim I_7$ is "L" and the level of E_{in} is "H". The level of GS, on the other hand, becomes "H" when the level of at least one priority input is "H" and the level of E_{in} is "H".

When the level of E_{in} is "L", the levels of all the outputs ($O_0 \sim O_2$, GS, E_{out}) become "L".

Pin description

- I_0 to I_7 : Priority input
- E_{in} : Enable input
- E_{out} : Enable output
- GS : Group select output
- O_0 to O_2 : Active output

■ Logic Diagram

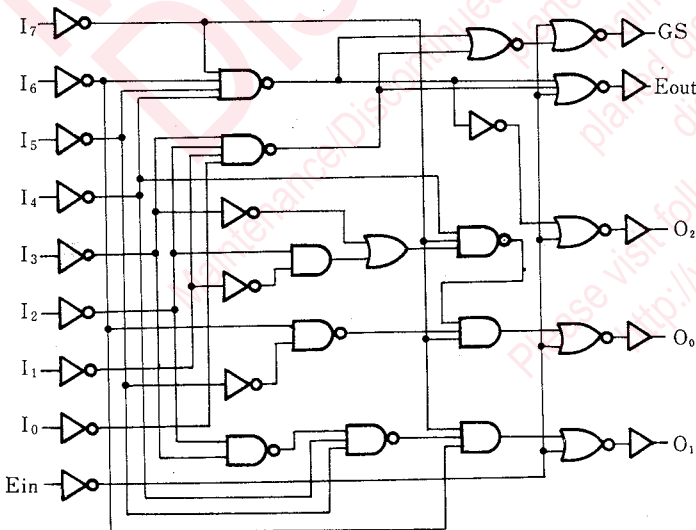

P-3

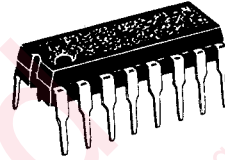

16-pin plastic DIL package

P-4

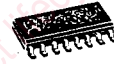

16-pin PANAFLAT package (SO-16D)

Pin Configuration

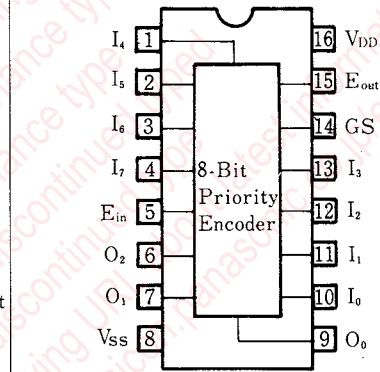

■ Absolute Maximum Ratings (Ta=25°C)

| Item | Symbol | Rating | Unit |
|------------------------------------|-------------------|---|------|
| Supply voltage | V _{DD} | -0.5~+18 | V |
| Input voltage | V _I | -0.5~V _{DD} +0.5* | V |
| Output pin voltage | V _O | -0.5~V _{DD} +0.5* | V |
| Peak input · output pin current | ±I _I | max. 10 | mA |
| Power dissipation (per package) | P _D | max. 400 | mW |
| | | Decrease to 200mW at the rate of 8mW/°C | |
| Power dissipation (per output pin) | P _D | max. 100 | mW |
| Operating ambient temperature | T _{opr} | -40~+85 | °C |
| Storage temperature | T _{strg} | -65~+150 | °C |

* V_{DD}+0.5V should be lower than 18V.

■ DC Characteristics (V_{SS}=0V)

| Item | V _{DD} (V) | Symbol | Condition | Ta=-40°C | | Ta=25°C | | Ta=85°C | | Unit | |
|---------------------------|---------------------|------------------|--|---|------|---------|------|---------|------|------|---|
| | | | | min. | max. | min. | max. | min. | max. | | |
| Static supply current | 5 | I _{DD} | V _I =V _{SS} or V _{DD} | — | 20 | — | 20 | — | 150 | μA | |
| | 10 | | | — | 40 | — | 40 | — | 300 | | |
| | 15 | | | — | 80 | — | 80 | — | 600 | | |
| Output voltage low level | 5 | V _{OL} | V _I =V _{SS} or V _{DD} I _O <1μA | — | 0.05 | — | 0.05 | — | 0.05 | V | |
| | 10 | | | — | 0.05 | — | 0.05 | — | 0.05 | | |
| | 15 | | | — | 0.05 | — | 0.05 | — | 0.05 | | |
| Output voltage high level | 5 | V _{OH} | V _I =V _{SS} or V _{DD} I _O <1μA | 4.95 | — | 4.95 | — | 4.95 | — | V | |
| | 10 | | | 9.95 | — | 9.95 | — | 9.95 | — | | |
| | 15 | | | 14.95 | — | 14.95 | — | 14.95 | — | | |
| Input voltage low level | 5 | V _{IL} | I _O <1μA | V _O =0.5V or 4.5V V _O =1V or 9V V _O =1.5V or 13.5V | — | 1.5 | — | 1.5 | — | 1.5 | V |
| | 10 | | | | — | 3 | — | 3 | — | 3 | |
| | 15 | | | | — | 4 | — | 4 | — | 4 | |
| Input voltage high level | 5 | V _{IH} | I _O <1μA | V _O =0.5V or 4.5V V _O =1V or 9V V _O =1.5V or 13.5V | 3.5 | — | 3.5 | — | 3.5 | — | V |
| | 10 | | | | 7 | — | 7 | — | 7 | — | |
| | 15 | | | | 11 | — | 11 | — | 11 | — | |
| Output current low level | 5 | I _{OL} | V _O =0.4V, V _I =0 or 5V V _O =0.5V, V _I =0 or 10V V _O =1.5V, V _I =0 or 15V | 0.52 | — | 0.44 | — | 0.36 | — | mA | |
| | 10 | | | 1.3 | — | 1.1 | — | 0.9 | — | | |
| | 15 | | | 3.6 | — | 3 | — | 2.4 | — | | |
| Output current high level | 5 | -I _{OH} | V _O =4.6V, V _I =0 or 5V V _O =9.5V, V _I =0 or 10V V _O =13.5V, V _I =0 or 15V | 0.52 | — | 0.44 | — | 0.36 | — | mA | |
| | 10 | | | 1.3 | — | 1.1 | — | 0.9 | — | | |
| | 15 | | | 3.6 | — | 3 | — | 2.4 | — | | |
| Output current high level | 5 | -I _{OH} | V _O =2.5V, V _I =0 or 5V | 1.7 | — | 1.4 | — | 1.1 | — | mA | |
| Input leakage current | 15 | ±I _I | V _I =0 or 15V | — | 0.3 | — | 0.3 | — | 1 | μA | |

■ Switching Characteristics (Ta=25°C, V_{SS}=0V, C_L=50pF)

| Item | V _{DD} (V) | Symbol | min. | typ. | max. | Unit |
|---|---------------------|------------------|------|------|------|------|
| Output rise time | 5 | | — | 60 | 120 | |
| | 10 | t _{TLH} | — | 30 | 60 | ns |
| | 15 | | — | 20 | 40 | |
| Output fall time | 5 | | — | 60 | 120 | |
| | 10 | t _{THL} | — | 30 | 60 | ns |
| | 15 | | — | 20 | 40 | |
| Propagation time E _{in} →E _{out} (L→H) | 5 | | — | 80 | 160 | |
| | 10 | t _{PLH} | — | 35 | 70 | ns |
| | 15 | | — | 30 | 60 | |
| Propagation time E _{in} →E _{out} (H→L) | 5 | | — | 95 | 190 | |
| | 10 | t _{PHL} | — | 45 | 90 | ns |
| | 15 | | — | 35 | 70 | |
| Propagation time E _{in} →GS (L→H) | 5 | | — | 80 | 160 | |
| | 10 | t _{PLH} | — | 40 | 80 | ns |
| | 15 | | — | 30 | 60 | |
| Propagation time E _{in} →GS (H→L) | 5 | | — | 85 | 170 | |
| | 10 | t _{PHL} | — | 45 | 90 | ns |
| | 15 | | — | 35 | 70 | |
| Propagation time E _{in} →On (L→H) | 5 | | — | 85 | 170 | |
| | 10 | t _{PLH} | — | 40 | 80 | ns |
| | 15 | | — | 30 | 60 | |
| Propagation time E _{in} →On (H→L) | 5 | | — | 80 | 160 | |
| | 10 | t _{PHL} | — | 40 | 80 | ns |
| | 15 | | — | 30 | 60 | |
| Propagation time In→On (H→L) | 5 | | — | 115 | 230 | |
| | 10 | t _{PLH} | — | 50 | 100 | ns |
| | 15 | | — | 35 | 70 | |
| Propagation time In→On (H→L) | 5 | | — | 115 | 230 | |
| | 10 | t _{PHL} | — | 50 | 100 | ns |
| | 15 | | — | 35 | 70 | |
| Propagation time In→GS (L→H) | 5 | | — | 115 | 230 | |
| | 10 | t _{PHL} | — | 50 | 100 | ns |
| | 15 | | — | 40 | 80 | |
| Propagation time In→GS (H→L) | 5 | | — | 115 | 230 | |
| | 10 | t _{PLH} | — | 50 | 100 | ns |
| | 15 | | — | 40 | 80 | |
| Input capacitance | | C _I | — | — | 7.5 | pF |

■ Truth Table

| inputs | | | | | | | | | outputs | | | | |
|----------|-------|-------|-------|-------|-------|-------|-------|-------|---------|-------|-------|-------|-----------|
| E_{in} | I_7 | I_6 | I_5 | I_4 | I_3 | I_2 | I_1 | I_0 | GS | O_2 | O_1 | O_0 | E_{out} |
| L | × | × | × | × | × | × | × | × | L | L | L | L | L |
| H | L | L | L | L | L | L | L | L | L | L | L | L | H |
| H | H | × | × | × | × | × | × | × | H | H | H | H | L |
| H | L | H | × | × | × | × | × | × | H | H | H | L | L |
| H | L | L | H | × | × | × | × | × | H | H | L | H | L |
| H | L | L | L | H | × | × | × | × | H | H | H | L | L |
| H | L | L | L | L | H | × | × | × | H | L | H | H | L |
| H | L | L | L | L | L | H | × | × | H | L | H | L | L |
| H | L | L | L | L | L | L | H | × | H | L | L | H | L |
| H | L | L | L | L | L | L | L | H | H | L | L | L | L |

H : "H" state

L : "L" state

× : state is immaterial

● Switching time measuring waveforms

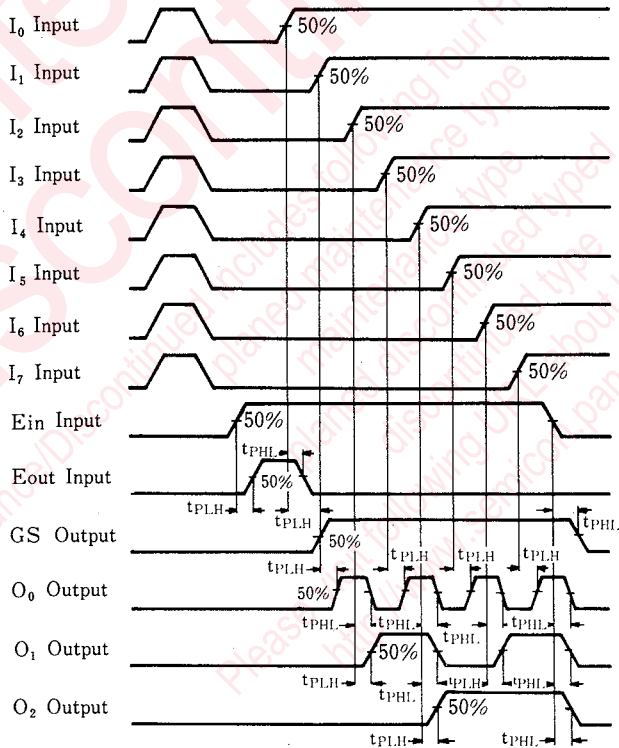

Request for your special attention and precautions in using the technical information and semiconductors described in this book

- (1) If any of the products or technical information described in this book is to be exported or provided to non-residents, the laws and regulations of the exporting country, especially, those with regard to security export control, must be observed.
- (2) The technical information described in this book is intended only to show the main characteristics and application circuit examples of the products. No license is granted in and to any intellectual property right or other right owned by Panasonic Corporation or any other company. Therefore, no responsibility is assumed by our company as to the infringement upon any such right owned by any other company which may arise as a result of the use of technical information described in this book.
- (3) The products described in this book are intended to be used for standard applications or general electronic equipment (such as office equipment, communications equipment, measuring instruments and household appliances).
Consult our sales staff in advance for information on the following applications:
 - Special applications (such as for airplanes, aerospace, automobiles, traffic control equipment, combustion equipment, life support systems and safety devices) in which exceptional quality and reliability are required, or if the failure or malfunction of the products may directly jeopardize life or harm the human body.
 - Any applications other than the standard applications intended.
- (4) The products and product specifications described in this book are subject to change without notice for modification and/or improvement. At the final stage of your design, purchasing, or use of the products, therefore, ask for the most up-to-date Product Standards in advance to make sure that the latest specifications satisfy your requirements.
- (5) When designing your equipment, comply with the range of absolute maximum rating and the guaranteed operating conditions (operating power supply voltage and operating environment etc.). Especially, please be careful not to exceed the range of absolute maximum rating on the transient state, such as power-on, power-off and mode-switching. Otherwise, we will not be liable for any defect which may arise later in your equipment.
 - Even when the products are used within the guaranteed values, take into the consideration of incidence of break down and failure mode, possible to occur to semiconductor products. Measures on the systems such as redundant design, arresting the spread of fire or preventing glitch are recommended in order to prevent physical injury, fire, social damages, for example, by using the products.
- (6) Comply with the instructions for use in order to prevent breakdown and characteristics change due to external factors (ESD, EOS, thermal stress and mechanical stress) at the time of handling, mounting or at customer's process. When using products for which damp-proof packing is required, satisfy the conditions, such as shelf life and the elapsed time since first opening the packages.
- (7) This book may be not reprinted or reproduced whether wholly or partially, without the prior written permission of our company.