

(TLP330)

PROGRAMMABLE CONTROLLERS

AC/DC-INPUT MODULE

TELECOMMUNICATION

The TOSHIBA TLP330 consists of a photo-transistor optically coupled to two gallium arsenide infrared emitting diode connected inverse parallel in a six lead plastic DIP package. This is suitable for application of AC input current up to 150mA.

- I_F Maximum Rating : $\pm 150\text{mA}$
- Collector-Emitter Voltage : 55V (Min.)
- Current Transfer Ratio : 25% (Min.) ($I_F = \pm 20\text{mA}$)
- Isolation Voltage : 5000Vrms (Min.)
- UL Recognized : UL1577, File No. E67349

PIN CONFIGURATIONS (TOP VIEW)

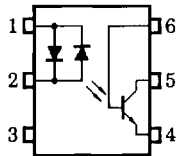

- 1 : ANODE, CATHODE
- 2 : CATHODE, ANODE
- 3 : NC
- 4 : EMITTER
- 5 : COLLECTOR
- 6 : BASE

Unit in mm

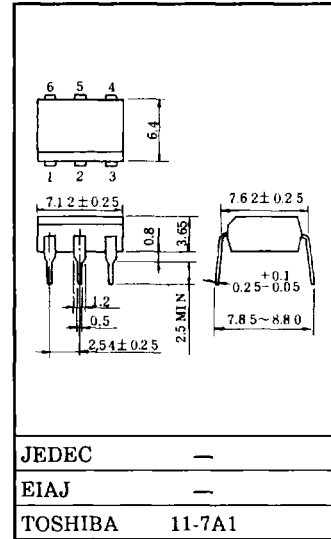

Weight : 0.4g

(TLP330)

MAXIMUM RATINGS (Ta = 25°C)

CHARACTERISTIC		SYMBOL	RATING	UNIT
LED	Forward Current	I _F	±150	mA
	Forward Current Derating (Ta ≥ 25°C)	ΔI _F /°C	-1.5	mA/°C
	Peak Forward Current (100μs pulse, 100pps)	I _{FP}	±1	A
	Junction Temperature	T _j	125	°C
DETECTOR	Collector-Emitter Voltage	V _{CEO}	55	V
	Collector-Base Voltage	V _{CBO}	80	V
	Emitter-Collector Voltage	V _{ECO}	7	V
	Emitter-Base Voltage	V _{EBO}	7	V
	Collector Current	I _C	80	mA
	Power Dissipation	P _C	150	mW
	Power Dissipation Derating (Ta ≥ 25°C)	ΔP _C /°C	-1.5	mW/°C
	Junction Temperature	T _j	125	°C
	Storage Temperature Range	T _{stg}	-55~125	°C
Operating Temperature Range	T _{opr}	-55~100	°C	
Lead Soldering Temperature (10 s)	T _{sol}	260	°C	
Total Package Power Dissipation	P _T	250	mW	
Total Package Power Dissipation Derating (Ta ≥ 25°C)	ΔP _T /°C	-2.5	mW/°C	
Isolation Voltage (AC, 1 min, RH ≤ 60%) (Note 1)	BV _S	5000	Vrms	

Note 1 : Device considered a two terminal device : Pins 1, 2 and 3 shorted together and pins 4, 5 and 6 shorted together.

(TLP330)

INDIVIDUAL ELECTRICAL CHARACTERISTICS (Ta = 25°C)

CHARACTERISTIC		SYMBOL	CONDITION	MIN.	TYP.	MAX.	UNIT
LED	Forward Voltage	V _F	I _F = ±100mA	—	1.4	1.7	V
	Forward Current	I _F	V _F = ±0.7V	—	2.5	20	μA
	Capacitance	C _T	V = 0, f = 1MHz	—	100	—	pF
DETECTOR	Collector-Emitter Breakdown Voltage	V _{(BR)CEO}	I _C = 0.5mA	55	—	—	V
	Emitter-Collector Breakdown Voltage	V _{(BR)ECO}	I _E = 0.1mA	7	—	—	V
	Collector-Base Breakdown Voltage	V _{(BR)CBO}	I _C = 0.1mA	80	—	—	V
	Emitter-Base Breakdown Voltage	V _{(BR)EBO}	I _E = 0.1mA	7	—	—	V
	Collector Dark Current	I _{CEO}	V _{CE} = 24V	—	10	100	nA
			V _{CE} = 24V, Ta = 85°C	—	2	50	μA
	Collector Dark Current	I _{CER}	V _{CE} = 24V, Ta = 85°C R _{BE} = 1MΩ	—	0.5	10	μA
	Collector Dark Current	I _{CBO}	V _{CB} = 10V	—	0.1	—	nA
	DC Forward Current Gain	h _{FE}	V _{CE} = 5V, I _C = 0.5mA	—	400	—	—
Capacitance (Collector to Emitter)	C _{CE}	V = 0, f = 1MHz	—	10	—	pF	

COUPLED ELECTRICAL CHARACTERISTICS (Ta = 25°C)

CHARACTERISTIC	SYMBOL	CONDITION	MIN.	TYP.	MAX.	UNIT
Current Transfer Ratio	I _C / I _F	I _F = ±20mA V _{CE} = 1V	25	—	—	%
	I _C / I _F (high)	I _F = ±100mA V _{CE} = 1V	20	—	80	%
Base Photo-Current	I _{PB}	V _F = ±5mA, V _{CB} = 5V	—	10	—	μA
Collector-Emitter Saturation Voltage	V _{CE(sat)}	I _C = 2.4mA, I _F = 20mA	—	—	0.4	V
		I _C = 2.4mA, I _F = ±100mA	—	—	0.4	
Off-State Collector Current	I _{C(off)}	V _F = ±0.7V, V _{CE} = 24V	—	1	10	μA
CTR Symmetry	I _C (ratio)	I _C (I _F = -20mA) / I _C (I _F = +20mA)	0.5	1	2	—

(TLP330)

ISOLATION CHARACTERISTICS (Ta = 25°C)

CHARACTERISTIC	SYMBOL	TEST CONDITION	MIN.	TYP.	MAX.	UNIT
Capacitance (Input to Output)	C _S	V _S =0, f=1MHz	—	0.8	—	pF
Isolation Resistance	R _S	V _S =500V	5×10 ¹⁰	10 ¹⁴	—	Ω
Isolation Voltage	BV _S	AC, 1 minute	5000	—	—	V _{rms}
		AC, 1 second, in oil	—	10000	—	V _{rms}
		DC, 1 minute, in oil	—	10000	—	V _{dc}

SWITCHING CHARACTERISTICS (Ta = 25°C)

CHARACTERISTIC	SYMBOL	TEST CONDITION	MIN.	TYP.	MAX.	UNIT
Rise Time	t _r	V _{CC} =10V I _C =2mA R _L =100Ω	—	2	—	μs
Fall Time	t _f		—	3	—	
Turn-on Time	t _{on}		—	3	10	
Turn-off Time	t _{off}		—	3	10	
Turn-on Time	t _{ON}	R _L =1.9kΩ (Fig.1)	—	2	—	μs
Storage Time	t _s	R _{BE} =OPEN	—	15	—	
Turn-off Time	t _{OFF}	V _{CC} =5V, I _F =±16mA	—	25	—	
Turn-on Time	t _{ON}	R _L =1.9kΩ (Fig.1)	—	2	—	μs
Storage Time	t _s	R _{BE} =220kΩ	—	12	—	
Turn-off Time	t _{OFF}	V _{CC} =5V, I _F =±16mA	—	20	—	

Fig.1 Switching Time Test Circuit

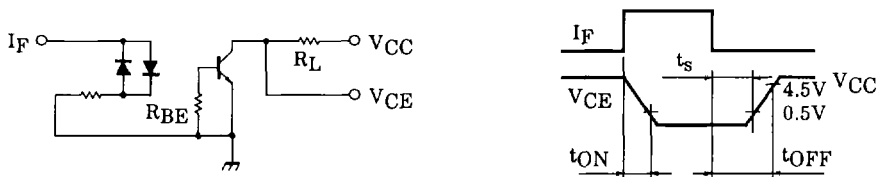

RECOMMENDED OPERATING CONDITIONS

CHARACTERISTIC	SYMBOL	MIN.	TYP.	MAX.	UNIT
Supply Voltage	V _{CC}	—	5	24	V
Forward Current	I _F (RMS)	—	20	120	mA
Collector Current	I _C	—	1	10	mA
Operating Temperature	T _{opr}	-25	—	85	°C

(TLP330)

