

### FEATURES

- HIGH OUTPUT POWER: 2 W MIN
- HIGH LINEAR GAIN: 7.0 dB MIN
- HIGH EFFICIENCY: 30% TYP
- INDUSTRY STANDARD PACKAGING
- INTERNALLY MATCHED FOR OPTIMUM PERFORMANCE IN 14.0 TO 14.5 GHz BAND

### DESCRIPTION

The NEZ1414-2E is a Ku band GaAs MESFET designed for transmit amplifiers used in VSAT terminals. The device is internally matched for the 14.0 to 14.5 GHz band and can deliver 2 W of output power when biased with 9 V. The device incorporates a Wsi (tungsten silicide) gate structure for high reliability, SiO<sub>2</sub> glassivation for surface stability, and a plated heat sink for reduced thermal resistance.

The NEZ1414-2E transistors are manufactured to NEC's stringent quality assurance standards to ensure highest reliability and consistent superior performance.

### OUTLINE DIMENSIONS

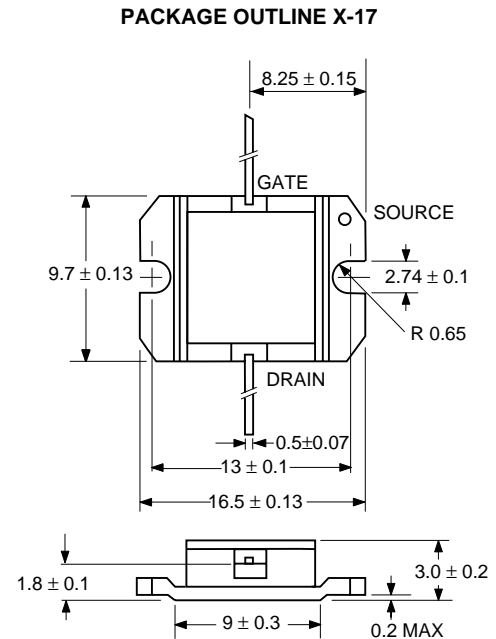

### ELECTRICAL CHARACTERISTICS (T<sub>c</sub> = 25°C)

PART NUMBER			NEZ1414-2E			TEST CONDITIONS
SYMBOLS	CHARACTERISTICS	UNITS	MIN	TYP	MAX	
P <sub>1dB</sub>	Power Out at 1 dB Compression	dBm	33.0	34.0		f = 14.0 to 14.5 GHz V <sub>DS</sub> = 9 V I <sub>DSQ</sub> = 0.7 A
G <sub>L</sub>	Linear Gain	dB	7.0	7.5		
η <sub>ADD</sub>	Power Added Efficiency @ P <sub>1dB</sub>	%		30		
I <sub>DS</sub>	Drain Source Current	A		0.8	1.0	
IM <sub>3</sub>	3rd Order Intermodulation Distortion	dBc		-45		P <sub>OUT</sub> = 23 dBm S.C.L. f = 14.25 GHz, Δf = 10 MHz
I <sub>DSS</sub>	Saturated Drain Current	A	0.7	1.6	2.5	V <sub>DS</sub> = 1.5 V, V <sub>GS</sub> = 0 V
V <sub>P</sub>	Pinch-off Voltage	V	-2.5	-1.3	-0.5	V <sub>DS</sub> = 2.5 V; I <sub>DS</sub> = 10 mA
BV <sub>GD</sub>	Gate-Drain Breakdown Voltage	V		15		I <sub>GD</sub> = 10 mA
R <sub>TH</sub>	Thermal Resistance	°C/W		5.5	7.0	Channel to Case

**ABSOLUTE MAXIMUM RATINGS**

(Tc = 25 °C unless otherwise noted)

SYMBOLS	PARAMETERS	UNITS	RATINGS
Vds	Drain to Source Voltage	V	15
Vgs	Gate to Source Voltage	V	-7
Ids	Drain Current	A	2.5
Igf	Gate Forward Current	mA	20
Igr	Gate Reverse Current	mA	-20
PT	Total Power Dissipation	W	15
Tch	Channel Temperature	°C	175
Tstg	Storage Temperature	°C	-65 to +175

Note:

1. Operation in excess of any one of these parameters may result in permanent damage.

**RECOMMENDED OPERATING LIMITS**

SYMBOLS	PARAMETERS	UNITS	MIN	TYP	MAX
Vds	Drain to Source Voltage	V		9	9
Tch	Channel Temperature	°C			130
GCOMP	Gain Compression	dB			3.0
Rg	Gate Resistance	Ω		100	200

**TYPICAL SCATTERING PARAMETERS**

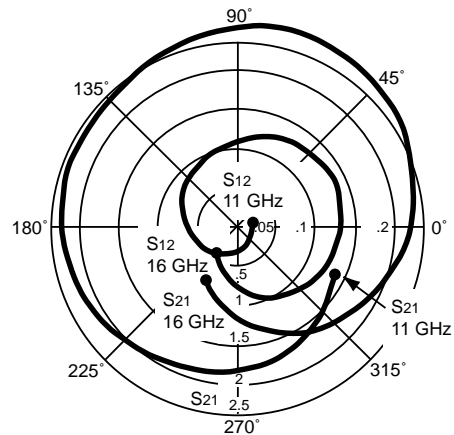
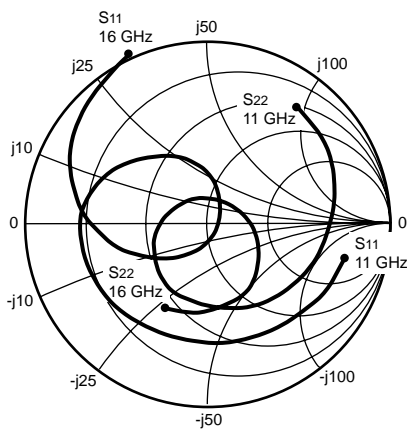

Vds = 9 V, Ids = 500 mA, Vgs = -1.05 V

FREQUENCY (GHz)	S11		S21		S12		S22		K	MAG <sup>1</sup> (dB)
	MAG	ANG	MAG	ANG	MAG	ANG	MAG	ANG		
11.000	0.779	-14.20	1.447	-24.50	0.020	6.80	0.808	51.10	1.98	12.9
11.500	0.690	-61.30	1.790	-63.60	0.029	-63.40	0.757	25.70	2.22	11.7
12.000	0.665	-113.50	2.005	-104.90	0.044	-123.00	0.661	-4.50	1.99	10.9
12.500	0.695	-156.60	2.203	-144.50	0.064	-170.30	0.579	-37.10	1.49	11.2
13.000	0.673	167.80	2.432	172.10	0.090	143.50	0.492	-76.10	1.30	11.1
13.500	0.522	135.10	2.447	129.20	0.108	100.50	0.409	-122.10	1.45	9.6
14.000	0.283	89.40	2.693	83.80	0.135	57.00	0.247	173.80	1.40	9.2
14.100	0.212	75.10	2.729	73.30	0.140	46.90	0.205	154.50	1.40	9.1
14.200	0.139	55.20	2.736	62.20	0.144	36.50	0.168	130.10	1.41	9.0
14.300	0.075	14.00	2.717	51.00	0.146	25.60	0.148	99.10	1.42	8.9
14.400	0.080	-67.40	2.677	39.60	0.146	14.80	0.149	65.70	1.43	8.7
14.500	0.153	-105.70	2.611	28.30	0.144	4.10	0.172	36.80	1.45	8.6
15.000	0.581	-173.30	2.067	-26.80	0.119	-47.90	0.364	-40.40	1.45	8.4
15.500	0.893	143.60	1.392	-77.60	0.078	-94.50	0.484	-83.00	1.03	11.5
16.000	1.012	115.10	0.870	-118.60	0.045	-126.80	0.528	-117.10	0.03	12.9

Note:

1. Gain Calculation:

$$MAG = \frac{|S_{21}|}{|S_{12}|} \left( K \pm \sqrt{K^2 - 1} \right). \text{ When } K \leq 1, \text{ MAG is undefined and MSG values are used. } MSG = \frac{|S_{21}|}{|S_{12}|}, K = \frac{1 + |\Delta|^2 - |S_{11}|^2 - |S_{22}|^2}{2 |S_{12} S_{21}|}, \Delta = S_{11} S_{22} - S_{21} S_{12}$$

MAG = Maximum Available Gain      MSG = Maximum Stable Gain

**TYPICAL SCATTERING PARAMETERS**

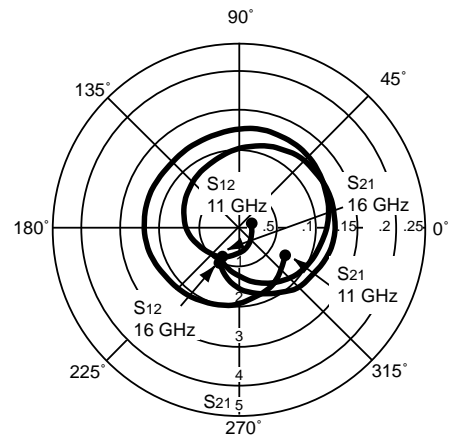
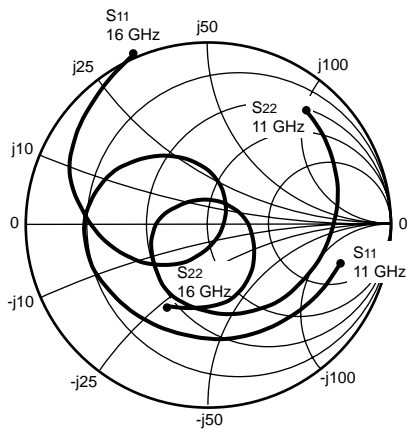

**V<sub>DS</sub> = 9 V, I<sub>DS</sub> = 700 mA, V<sub>GS</sub> = -0.868 V**

FREQUENCY (GHz)	S <sub>11</sub>		S <sub>21</sub>		S <sub>12</sub>		S <sub>22</sub>		K	MAG <sup>1</sup> (dB)
	MAG	ANG	MAG	ANG	MAG	ANG	MAG	ANG		
11.00	0.752	-17.70	1.499	-27.50	0.021	15.40	0.816	50.10	1.84	13.2
11.50	0.665	-65.90	1.852	-66.70	0.027	-54.60	0.768	24.60	2.23	12.1
12.00	0.646	-118.50	2.072	-108.20	0.040	-118.30	0.674	-6.10	2.06	11.3
12.50	0.678	-161.50	2.278	-148.00	0.059	-168.50	0.596	-39.20	1.54	11.5
13.00	0.647	162.90	2.503	168.40	0.083	144.00	0.514	-78.40	1.36	11.2
13.50	0.492	129.50	2.533	125.50	0.101	100.70	0.436	-124.20	1.49	9.8
14.00	0.245	78.80	2.783	79.20	0.128	56.20	0.270	175.10	1.44	9.5
14.10	0.175	61.00	2.815	68.40	0.131	45.90	0.224	157.80	1.44	9.4
14.20	0.108	30.10	2.812	57.30	0.134	35.40	0.181	136.60	1.45	9.2
14.30	0.081	-31.00	2.782	45.90	0.136	24.60	0.150	108.40	1.46	9.1
14.40	0.129	-84.80	2.731	34.50	0.135	13.70	0.137	75.40	1.48	9.9
14.50	0.206	-111.50	2.652	23.30	0.134	3.10	0.149	43.10	1.50	8.8
15.00	0.621	-175.30	2.080	-31.50	0.110	-48.30	0.330	-40.60	1.46	8.7
15.50	0.905	141.50	1.390	-82.00	0.072	-94.10	0.454	-82.90	1.01	12.2
16.00	1.010	113.10	0.867	-122.80	0.041	-125.50	0.503	-116.80	0.02	13.2

Note:

1. Gain Calculation:

$$MAG = \frac{|S_{21}|}{|S_{12}|} (K \pm \sqrt{K^2 - 1})$$

When  $K \leq 1$ , MAG is undefined and MSG values are used.  $MSG = \frac{|S_{21}|}{|S_{12}|}$ ,  $K = \frac{1 + |\Delta|^2 - |S_{11}|^2 - |S_{22}|^2}{2 |S_{12} S_{21}|}$ ,  $\Delta = S_{11} S_{22} - S_{21} S_{12}$

MAG = Maximum Available Gain      MSG = Maximum Stable Gain

TYPICAL SCATTERING PARAMETERS

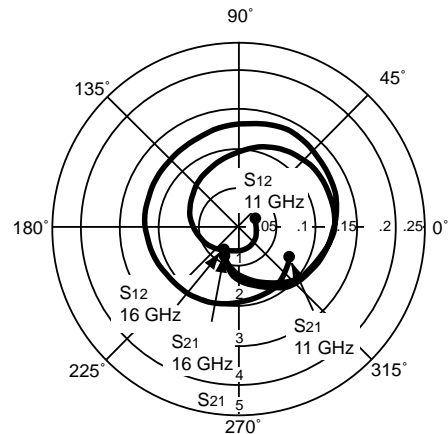
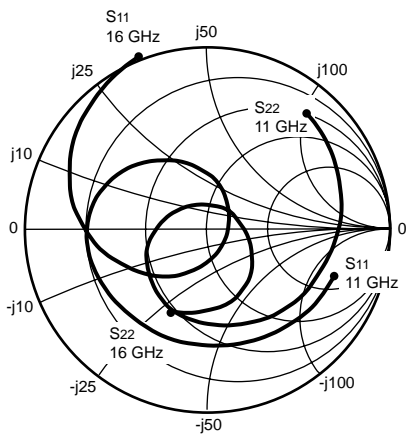

V<sub>DS</sub> = 9 V, I<sub>DS</sub> = 900 mA, V<sub>GS</sub> = -0.698 V

FREQUENCY	S <sub>11</sub>		S <sub>21</sub>		S <sub>12</sub>		S <sub>22</sub>		K	MAG <sup>1</sup>
(GHz)	MAG	ANG	MAG	ANG	MAG	ANG	MAG	ANG		(dB)
11.00	0.740	-19.40	1.546	-28.50	0.023	22.80	0.825	50.00	1.59	13.8
11.50	0.652	-68.00	1.909	-67.70	0.026	-46.70	0.781	24.50	2.10	12.7
12.00	0.637	-120.90	2.136	-109.10	0.037	-113.30	0.690	-6.30	2.04	11.8
12.50	0.671	-163.90	2.354	-149.00	0.055	-165.50	0.615	-39.60	1.53	12.0
13.00	0.636	160.30	2.587	167.20	0.078	145.90	0.537	-79.00	1.36	11.6
13.50	0.478	126.20	2.625	124.20	0.096	102.10	0.459	-124.60	1.49	10.2
14.00	0.229	70.40	2.890	77.40	0.122	56.90	0.294	176.60	1.43	9.9
14.10	0.161	48.60	2.915	66.50	0.126	46.40	0.246	160.50	1.43	9.7
14.20	0.109	9.70	2.909	55.30	0.129	35.90	0.200	141.30	1.44	9.6
14.30	0.109	-46.90	2.873	43.80	0.130	24.90	0.162	116.50	1.46	9.4
14.40	0.163	-87.50	2.812	32.50	0.130	14.20	0.140	86.00	1.48	9.3
14.50	0.240	-111.30	2.727	21.20	0.128	3.70	0.140	52.70	1.50	9.1
15.00	0.644	-175.40	2.127	-33.60	0.104	-47.60	0.305	-38.30	1.44	9.2
15.50	0.917	141.10	1.416	-83.90	0.068	-93.10	0.431	-81.30	0.94	13.2
16.00	1.016	112.60	0.881	-124.60	0.039	-123.70	0.486	-115.20	-0.13	13.5

Note:

1. Gain Calculation:

$$MAG = \frac{|S_{21}|}{|S_{12}|} (K \pm \sqrt{K^2 - 1})$$

When  $K \leq 1$ , MAG is undefined and MSG values are used.  $MSG = \frac{|S_{21}|}{|S_{12}|}$ ,  $K = \frac{1 + |\Delta|^2 - |S_{11}|^2 - |S_{22}|^2}{2 |S_{12} S_{21}|}$ ,  $\Delta = S_{11} S_{22} - S_{21} S_{12}$

MAG = Maximum Available Gain      MSG = Maximum Stable Gain

EXCLUSIVE NORTH AMERICAN AGENT FOR **NEC** RF, MICROWAVE & OPTOELECTRONIC SEMICONDUCTORS

**CEL** CALIFORNIA EASTERN LABORATORIES • Headquarters • 4590 Patrick Henry Drive • Santa Clara, CA 95054-1817 • (408) 988-3500 • Telex 34-6393 • FAX (408) 988-0279  
24-Hour Fax-On-Demand: 800-390-3232 (U.S. and Canada only) • Internet: <http://WWW.CEL.COM>

DATA SUBJECT TO CHANGE WITHOUT NOTICE

10/16/2000