

### 1. General Description

The H18GDA23H is a CMOS (0.18 $\mu$ m, 1-poly, 3-metal, MIM) 10-bit DAC( Digital-to-Analog converter ) for industry. This DAC cell adapts resistor string method which enables simple implementation.

This DAC offers low speed (2MHz), low power consumption.

### 2. Features

- Resistor string type
- Resolution: 10 bits
- Conversion rate: 2Msps
- Power supply: 3.3 V
- Power dissipation: 19.2mW (@2MHz)
- Process: 0.18 $\mu$ m CMOS generic Process (1-Poly, 3-Metal, MIM-cap, Thick Gox)
- Cell Size: 480 $\mu$ m  $\times$  760  $\mu$ m( with guard ring )

### 3. Block Diagram with Recommended Application Circuit

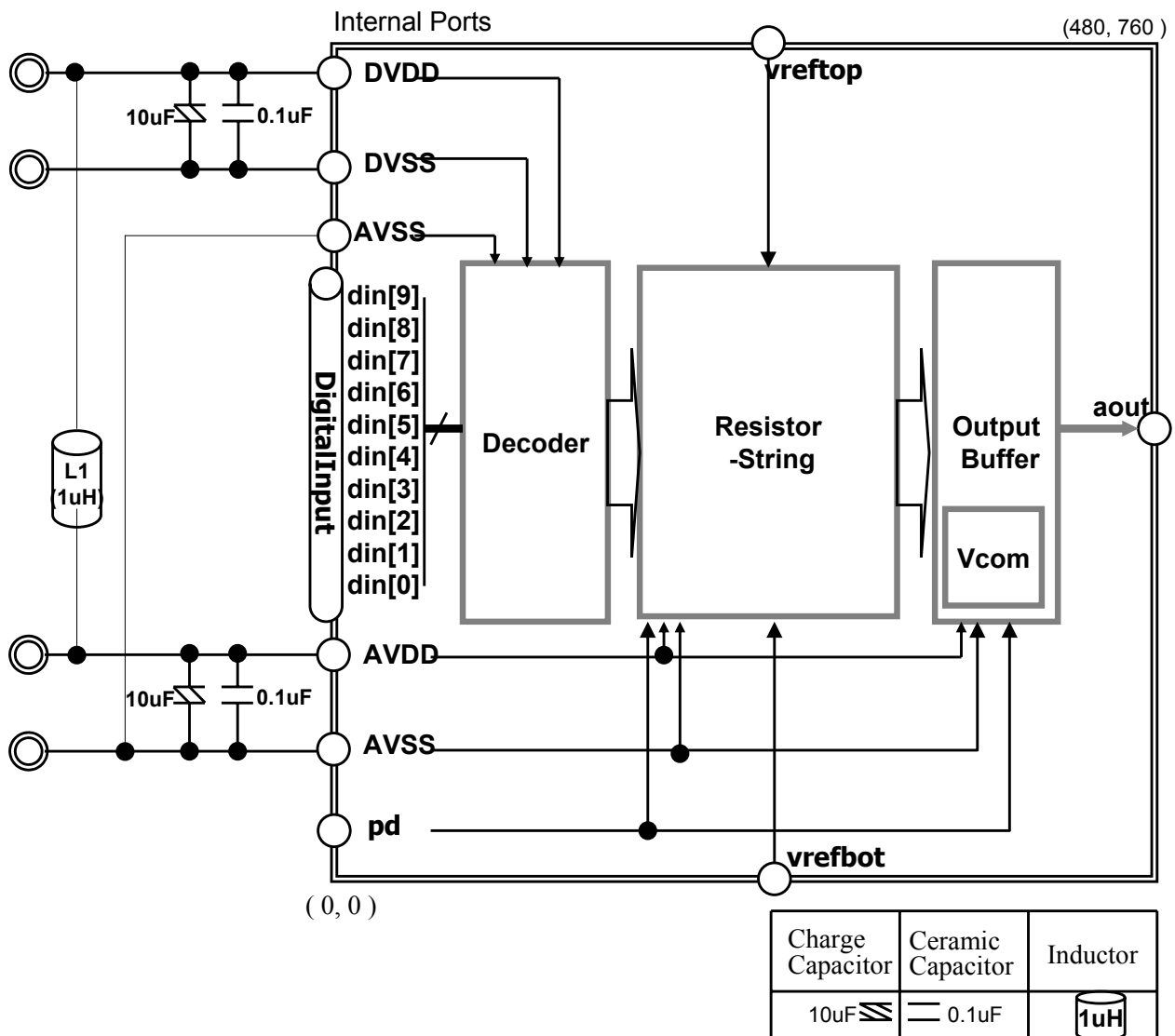

## 4. Pin Descriptions

Name	Type	Description
AVDD	Power	Analog Power
AVSS	Ground	Analog Ground
DVDD	Power	Digital Power
DVSS	Ground	Digital Ground
din[0]	Input	Digital Input[LSB]
din[1]	Input	Digital Input
din[2]	Input	Digital Input
din[3]	Input	Digital Input
din[4]	Input	Digital Input
din[5]	Input	Digital Input
din[6]	Input	Digital Input
din[7]	Input	Digital Input
din[8]	Input	Digital Input
din[9]	Input	Digital Input[MSB]
pd	Input	Power Down switch
vreftop	Input	Reference top voltage(3.3V)
vrefbot	Input	Reference bottom voltage(0V)
aout	Output	Analog Output Signal

## 5. Function Descriptions

### Normal Operation

When the input digital(din[9] ~ din[0]) is applied, the decoder produces column line bit and row line bit. The column/row line bit selects one voltage point and the selected voltage level produces the output voltage through the output buffer. The range of output voltage is 0.45v ~ 2.85v.

### Power down Operation

To minimize power consumption, a power-down mode is provided. For power down, an external high signal is applied to pd. In the power-down mode, the average power consumption is reduced to  $\geq 1\mu\text{A}$

## 6. Operating Conditions

Symbol	Parameter	Min.	Typ.	Max.	Unit
DVDD	Digital Power Supply	3.0	3.3	3.6.	V
AVDD	Analog Power Supply	3.0	3.3	3.6.	V
T <sub>PWL</sub>	Clock Pulse Width	0.25	-	-	us
T <sub>PWH</sub>		0.25	-	-	
T <sub>OP</sub>	Operating Temperature	0	25	100	°C

## 7. Electrical Characteristics

Symbol	Parameter	Conditions	Min.	Typ.	Max.	Unit
I <sub>dd</sub>	Normal Operation	pd=Low		5.8	6	mA.
	Power Down	pd=High		-	≤1	uA
Accuracy	Resolution			10		bits
INL	Integral Nonlinearity	DC	-1.0		+1.0	LSB
DNL	Differential Nonlinearity	DC	-0.5		+0.5	LSB
SNR	Signal to Noise Ratio		45	50		dB
THD	Total Harmonic Distortion			50		dB
f <sub>CON</sub>	Conversion Speed			2		Msp/s
tr/tf	Rise/Fall time	with ±10%Error		0.02/0.02		us
t <sub>d</sub>	Output Delay Time			0.02		us
t <sub>s</sub>	Output Settling time			0.05		us
V <sub>OP-P</sub>	Output Voltage Range		0.45		2.85	V

## 8. Timing Diagram

