

The RF TMOS® Line
Power Field Effect Transistor
N-Channel Enhancement Mode

Designed for wideband large-signal amplifier and oscillator applications to 500 MHz.

- Guaranteed 28 Volt, 400 MHz Performance
 Output Power = 2.0 Watts
 Minimum Gain = 16 dB
 Efficiency = 55% (Typical)
- Grounded Source Package for High Gain and Excellent Heat Dissipation (MRF158R)
- Facilitates Manual Gain Control, ALC and Modulation Techniques
- 100% Tested for Load Mismatch at All Phase Angles with 30:1 VSWR
- Excellent Thermal Stability, Ideally Suited for Class A Operation

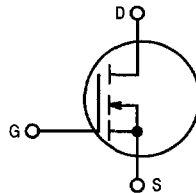

MRF158
MRF158R

Motorola Preferred Devices

2.0 W, to 500 MHz
TMOS
BROADBAND
RF POWER FET

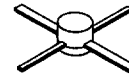

CASE 305A, STYLE 2

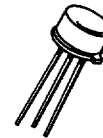

CASE 79-05, STYLE 7

MAXIMUM RATINGS

Rating	Symbol	Value	Unit
Drain-Source Voltage	V_{DSS}	65	Vdc
Drain-Gate Voltage ($R_{GS} = 1.0 \text{ M}\Omega$)	V_{DGR}	65	Vdc
Gate-Source Voltage	V_{GS}	± 40	Vdc
Drain Current — Continuous	I_D	0.5	Adc
Total Device Dissipation @ $T_C = 25^\circ\text{C}$ Derate above 25°C	P_D	8.0 45	Watts mW/ $^\circ\text{C}$
Storage Temperature Range	T_{stg}	-65 to +150 -65 to +200	$^\circ\text{C}$
Operating Junction Temperature	T_J	200	$^\circ\text{C}$

THERMAL CHARACTERISTICS

Characteristic	Symbol	Max	Unit
Thermal Resistance, Junction to Case	$R_{\theta JC}$	13.2 22	$^\circ\text{C}/\text{W}$

NOTE — **CAUTION** — MOS devices are susceptible to damage from electrostatic charge. Reasonable precautions in handling and packaging MOS devices should be observed.

Preferred devices are Motorola recommended choices for future use and best overall value.

ELECTRICAL CHARACTERISTICS ($T_C = 25^\circ\text{C}$ unless otherwise noted.)

Characteristic	Symbol	Min	Typ	Max	Unit
----------------	--------	-----	-----	-----	------

OFF CHARACTERISTICS

Drain-Source Breakdown Voltage ($V_{GS} = 0$, $I_D = 5.0$ mA)	$V_{(BR)DSS}$	65	—	—	Vdc
Zero Gate Voltage Drain Current ($V_{DS} = 28$ V, $V_{GS} = 0$)	I_{DSS}	—	—	0.5	mAdc
Gate-Source Leakage Current ($V_{GS} = 40$ V, $V_{DS} = 0$)	I_{GSS}	—	—	1.0	μAdc

ON CHARACTERISTICS

Gate Threshold Voltage ($I_D = 10$ mA, $V_{DS} = 10$ V)	$V_{GS(th)}$	1.0	4.0	6.0	Vdc
Forward Transconductance ($V_{DS} = 10$ V, $I_D = 100$ mA)	g_{fs}	50	85	—	mmhos

DYNAMIC CHARACTERISTICS

Input Capacitance ($V_{DS} = 28$ V, $V_{GS} = 0$, $f = 1.0$ MHz)	C_{iss}	—	3.0	—	pF
Output Capacitance ($V_{DS} = 28$ V, $V_{GS} = 0$, $f = 1.0$ MHz)	C_{oss}	—	4.2	—	pF
Reverse Transfer Capacitance ($V_{DS} = 28$ V, $V_{GS} = 0$, $f = 1.0$ MHz)	C_{rss}	—	0.45	—	pF

FUNCTIONAL CHARACTERISTICS (Figure 1)

Common Source Power Gain ($V_{DD} = 28$ Vdc, $P_{out} = 2.0$ W, $f = 400$ MHz, $I_{DQ} = 100$ mA)	G_{ps}	16	20	—	dB
Drain Efficiency (Figure 1) ($V_{DD} = 28$ Vdc, $P_{out} = 2.0$ W, $f = 400$ MHz, $I_{DQ} = 100$ mA)	η	45	55	—	%
Electrical Ruggedness (Figure 1) ($V_{DD} = 28$ Vdc, $P_{out} = 2.0$ W, $f = 400$ MHz, $I_{DQ} = 100$ mA, VSWR 30:1 at all Phase Angles)	ψ	No Degradation in Outout Power			
MRF158 Series Equivalent Input Impedance ($V_{DD} = 28$ V, $P_{out} = 2.0$ W, $f = 400$ MHz, $I_{DQ} = 100$ mA)	Z_{in}	—	$8.8 - j27.37$	—	Ohms
Series Equivalent Output Impedance ($V_{DD} = 28$ V, $P_{out} = 2.0$ W, $f = 400$ MHz, $I_{DQ} = 100$ mA)	Z_{out}	—	$16.96 - j62$	—	Ohms

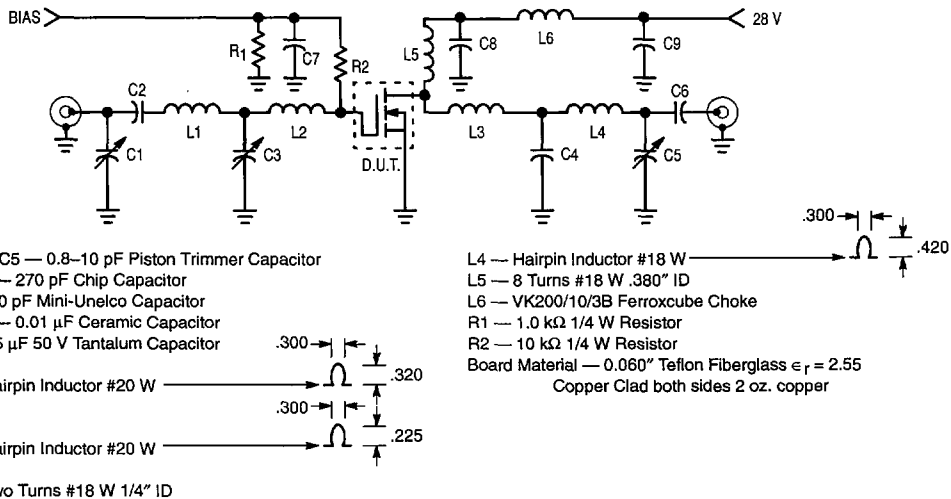

Figure 1. 400 MHz Test Circuit, MRF158R

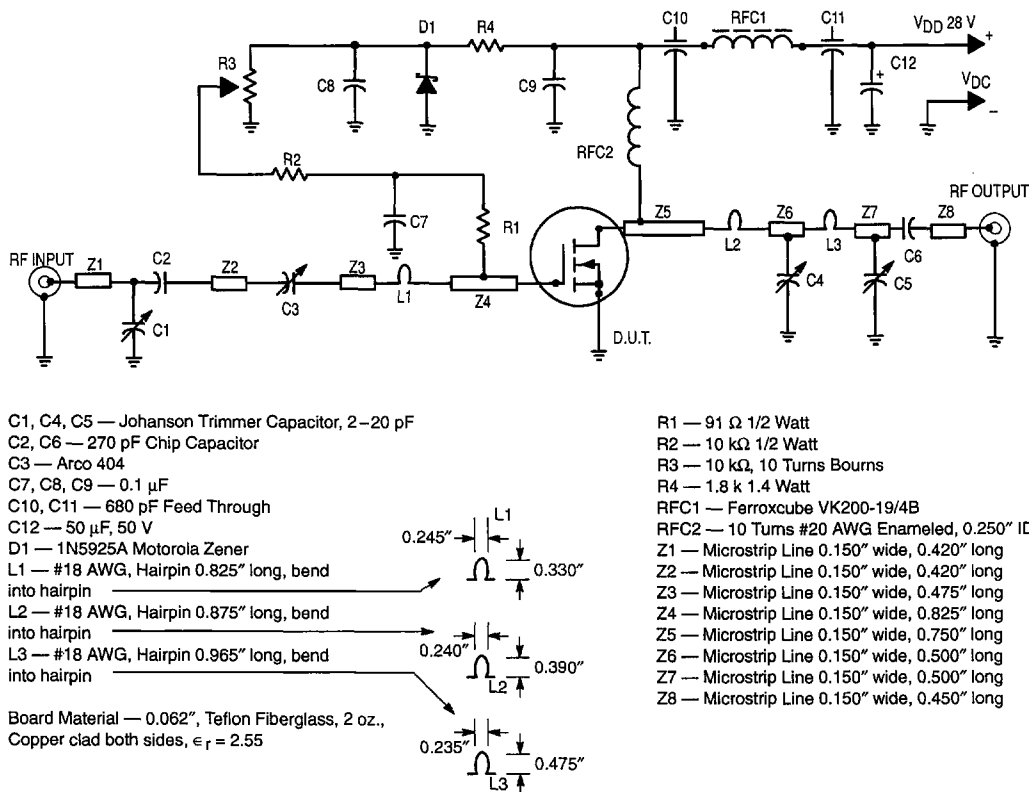

Figure 2. 400 MHz Test Circuit, MRF158

TYPICAL CHARACTERISTICS

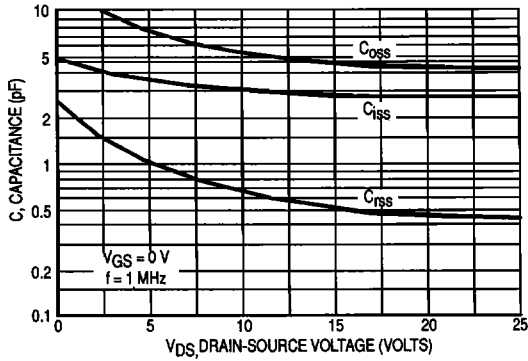

Figure 3. Capacitance versus Drain-Source Voltage

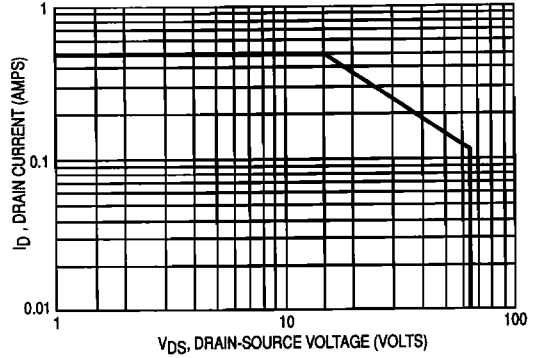

Figure 4. DC Safe Operating Area

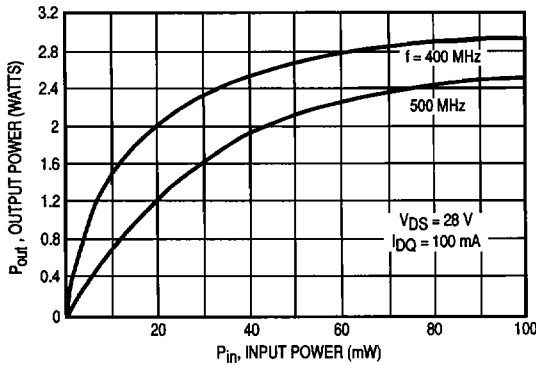

Figure 5. Output Power versus Input Power

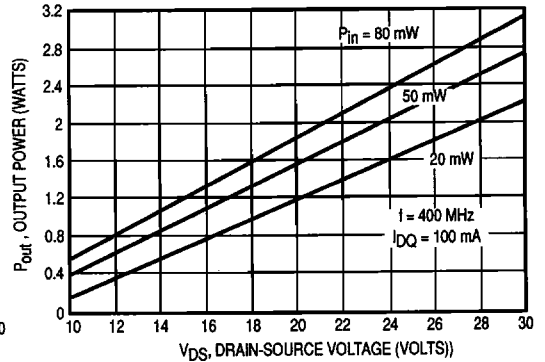

Figure 6. Output Power versus Voltage

MRF158R ONLY

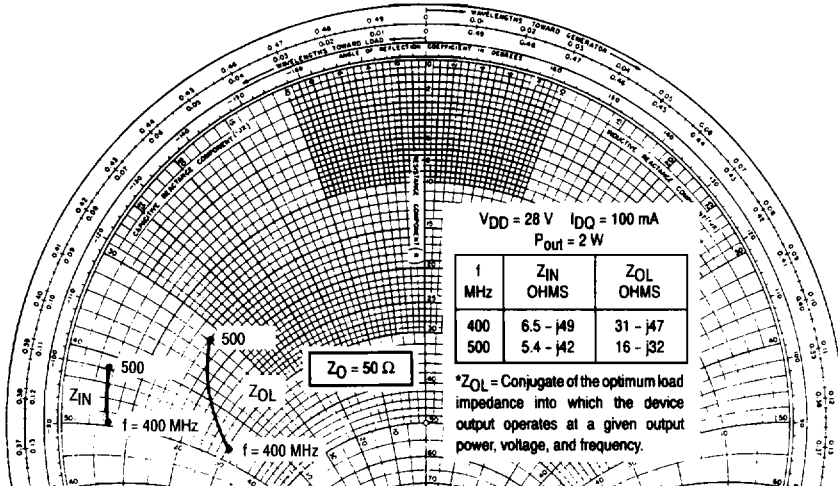

Figure 7. Series Equivalent Input and Output Impedances

Table 1. Typical Common Emitter S-Parameters (MRF158R)

V _{DS} (Volts)	I _D (mA)	f (MHz)	S ₁₁		S ₂₁		S ₁₂		S ₂₂	
			S ₁₁	∠φ	S ₂₁	∠φ	S ₁₂	∠φ	S ₂₂	∠φ
28	100	5	1.00	-3.0	6.47	178	0.003	54	0.95	-3.0
		10	1.00	-3.0	5.95	176	0.003	83	0.95	-2.0
		20	1.00	-5.0	5.87	174	0.006	76	0.95	-4.0
		30	0.99	-8.0	5.86	171	0.009	82	0.95	-6.0
		40	0.99	-10	5.77	168	0.011	81	0.95	-8.0
		50	0.98	-12	5.71	165	0.014	77	0.95	-10
		100	0.95	-24	5.42	153	0.026	68	0.92	-20
		150	0.89	-34	5.07	141	0.034	61	0.89	-28
		200	0.83	-43	4.64	131	0.039	55	0.85	-36
		250	0.78	-51	4.26	121	0.040	51	0.80	-43
		300	0.73	-59	3.87	112	0.039	50	0.77	-48
		350	0.68	-65	3.55	104	0.036	53	0.73	-53
		400	0.64	-71	3.22	97	0.033	63	0.70	-58
		500	0.58	-82	2.77	84	0.037	96	0.64	-69
		600	0.54	-94	2.42	72	0.064	115	0.62	-79
		700	0.54	-107	2.19	63	0.100	117	0.62	-91
800	0.54	-118	1.99	53	0.147	117	0.64	-101		
900	0.55	-129	1.81	45	0.209	112	0.64	-112		
1000	0.56	-138	1.66	37	0.283	105	0.64	-120		

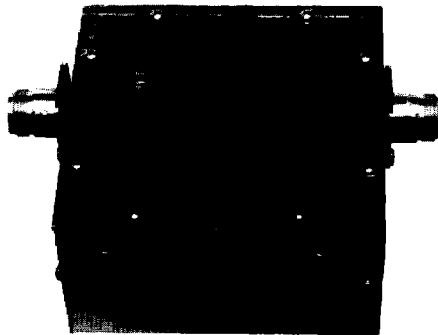

Figure 8. Test Circuit, Top View (MRF158R)



Figure 9. Test Circuit, Bottom View (MRF158R)

MRF158 ONLY

Table 2. Typical Common Emitter S-Parameters (MRF158)

V _{DS} (Volts)	I _D (mA)	f (MHz)	S ₁₁		S ₂₁		S ₁₂		S ₂₂	
			S ₁₁	∠φ	S ₂₁	∠φ	S ₁₂	∠φ	S ₂₂	∠φ
28	100	5	1.00	-2.0	3.84	-179	0.003	73	0.97	-2.0
		10	1.00	-2.0	3.81	179	0.004	83	0.97	-2.0
		30	1.00	-7.0	3.74	174	0.011	81	0.97	-6.0
		50	1.00	-11	3.72	170	0.018	78	0.96	-9.0
		100	0.98	-21	3.62	159	0.034	70	0.95	-19
		200	0.93	-41	3.28	137	0.061	52	0.90	-35
		300	0.88	-58	2.88	120	0.077	39	0.86	-50
		400	0.83	-75	2.57	104	0.088	27	0.81	-63
		500	0.79	-87	2.24	91	0.090	17	0.78	-74
		600	0.75	-99	1.94	78	0.084	8.0	0.75	-84
		700	0.73	-110	1.72	68	0.077	2.0	0.75	-93
		800	0.72	-120	1.52	58	0.067	-3.0	0.75	-99
900	0.71	-130	1.35	48	0.055	-6.0	0.74	-108		
1000	0.71	-139	1.18	40	0.043	-4.0	0.73	-114		

2



Figure 10. Test Circuit (MRF158)

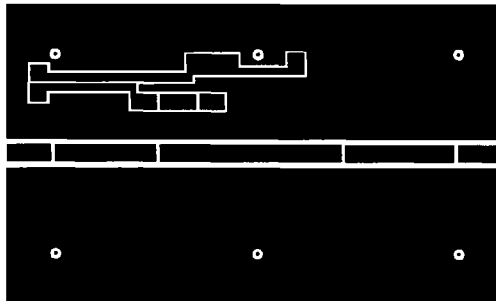

(Not to Scale)

Figure 11. PC Board Photomaster (MRF158)