

2M x 32 5.0V IC DRAM Card
Features

- Industry Standard 88Pin IC DRAM Card
- Performance:

		-70
t_{RAC}	\overline{RAS} Access Time	70ns
t_{CAC}	\overline{CAS} Access Time	29ns
t_{AA}	Access Time From Address	46ns
t_{RC}	Cycle Time	130ns
t_{PC}	Fast Page Mode Cycle Time	50ns

- Industry Standard DRAM functions & timings
- High Performance CMOS process

- Single 5.0V, $\pm 0.25V$ Power Supply
- All inputs buffered except \overline{RAS} and DATA inputs
- Multiple \overline{RAS} inputs for x16 or x32 selectability
- 10/10 Addressing (Row/Column)
- Optional Fast Page Mode access cycle
- Refresh Modes: \overline{RAS} -Only, \overline{CAS} before \overline{RAS} and BBU (Battery Backup)
- 1024 refresh cycles distributed across 128ms
- Polarized Connector

Description

The IBM11J2320BL is a 8MB industry standard 88-pin IC DRAM card. It is organized as a 2M x 32 high speed memory array. It is built using 16 - 1Mx4 devices and is compatible to the JEDEC/PCM-CIA/JEIDA 88-pin standard. Improved system performance is provided by the on-card buffering of selected input signals. The specified timings include all buffer, net and skew delays, which allow the system designer to work with a simpler interface. The DQ and \overline{RAS} signals are not buffered, which preserves the access specification of 70ns. Multiple \overline{RAS} inputs are used to conserve power by allowing individual bank selection. In the x32 configuration

the memory may be utilized as two banks, each having four unique bytes. The x16 configuration may be utilized as four banks each having two unique bytes. Only one bank is activated by each \overline{RAS} , leaving the other banks in standby mode, thus saving power. All IBM IC DRAM cards are packaged in a rugged metal case for maximum device protection in portable applications. The related 2M x 36 version of this ICDRAM card is IBM11J2360BLA

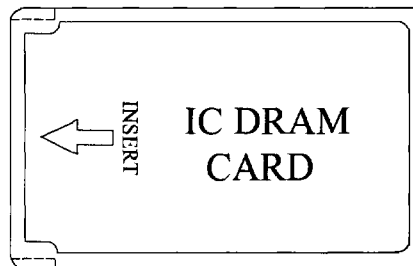
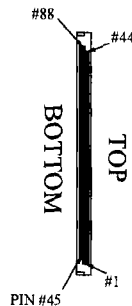
Card Outline



2M x 32 5.0V IC DRAM Card

Pin Description

$\overline{\text{RAS0}} - \overline{\text{RAS3}}$	Row Address Strobe
$\overline{\text{CAS0}} - \overline{\text{CAS3}}$	Column Address Strobe
$\overline{\text{WE}}$	Read/write Input
A0 - A9	Address Inputs
DQ0-7, 9-16, 18-25, 27-34	Data Input/output
V _{CC}	Power (+5V)
V _{SS}	Ground
NC	No Connect
PD1 - PD8	Presence Detects

Pinout

Pin#	Name	Pin#	Name	Pin#	Name	Pin#	Name
1	V _{SS}	23	CAS0	45	V _{SS}	67	V _{SS}
2	DQ0	24	CAS1	46	DQ18	68	CAS3
3	DQ1	25	NC	47	DQ19	69	RAS3
4	DQ2	26	RAS2	48	DQ20	70	WE
5	DQ3	27	V _{CC}	49	DQ21	71	PD1
6	DQ4	28	PD2	50	DQ22	72	PD3
7	DQ5	29	PD4	51	DQ23	73	V _{SS}
8	DQ6	30	PD6	52	DQ24	74	PD5
9	V _{CC}	31	NC	53	DQ25	75	PD7
10	DQ7	32	NC	54	NC	76	PD8
11	NC	33	NC	55	NC	77	NC
12	NC	34	DQ9	56	V _{SS}	78	NC
13	A0	35	NC	57	A1	79	NC
14	A2	36	DQ10	58	A3	80	DQ27
15	V _{CC}	37	V _{CC}	59	A5	81	DQ28
16	A4	38	DQ11	60	A7	82	DQ29
17	NC	39	DQ12	61	A9	83	DQ30
18	A6	40	DQ13	62	NC	84	DQ31
19	A8	41	DQ14	63	V _{SS}	85	DQ32
20	NC	42	DQ15	64	NC	86	DQ33
21	NC	43	DQ16	65	RAS1	87	DQ34
22	RAS0	44	V _{SS}	66	CAS2	88	V _{SS}

1. DQ numbering is compatible with parity (x36) version)

Ordering Information

Part Number	Organization	Speed	Notes
IBM11J2320BLA-70	2M x 32	70ns	For 80ns applications use this 70ns Part Number. Be aware if the application makes use of PD's, PD6 & PD7 are different from the 70ns version.

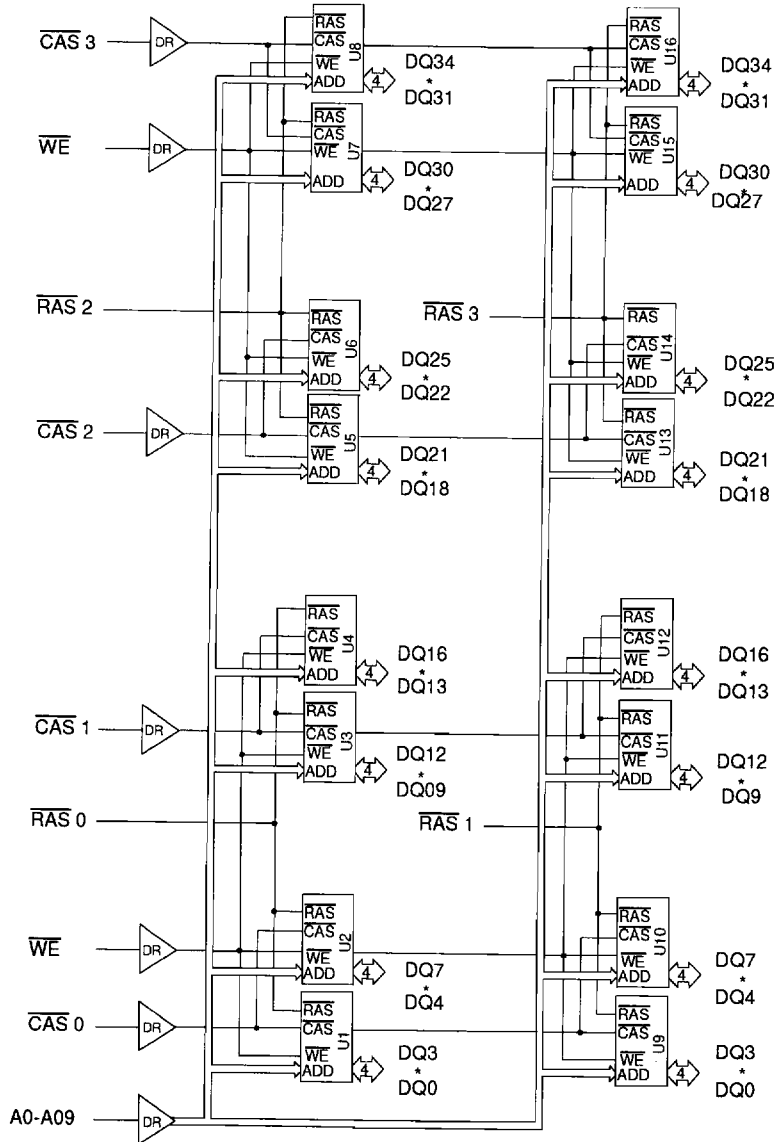
Block Diagram

2M x 32 5.0V IC DRAM Card
Truth Table

Function	$\overline{\text{RAS}}$	$\overline{\text{CAS}}$	$\overline{\text{WE}}$	Row Address	Column Address	All DQ bits
Standby	H	X	X	X	X	High Impedance
Read	L	L	H	Row	Col	Valid Data Out
Early-Write	L	L	L	Row	Col	Valid Data In
Fast Page Mode - Read: 1st Cycle	L	H→L	H	Row	Col	Valid Data Out
Subsequent Cycles	L	H→L	H	N/A	Col	Valid Data Out
Fast Page Mode - Write: 1st Cycle	L	H→L	L	Row	Col	Valid Data In
Subsequent Cycles	L	H→L	L	N/A	Col	Valid Data In
$\overline{\text{RAS}}$ -Only Refresh	L	H	X	Row	N/A	High Impedance
$\overline{\text{CAS}}$ -Before- $\overline{\text{RAS}}$ Refresh	H→L	L	H	X	X	High Impedance

Presence Detect

Pin	-70
PD1 (PD1 - PD4: Addressing/Dram Type)	V_{SS}
PD2	NC
PD3	V_{SS}
PD4	V_{SS}
PD5 (Number of Banks/Organization)	V_{SS}
PD6 (Speed)	V_{SS}
PD7	NC
PD8 (Refresh Type)	NC
1. NC= OPEN, V_{SS} = GND	

Absolute Maximum Ratings

Symbol	Parameter	Rating	Units	Notes
V_{CC}	Power Supply Voltage	-1.0 to +6.0	V	1
V_{IN}	Input Voltage (\overline{RAS} & DATA)	-1.0 to +6.0	V	1
	Input Voltage (Redriven Signals)	-0.5 to $V_{CC} + 0.5$	V	1
V_{OUT}	Output Voltage	-1.0 to +6.0	V	1
T_{OPR}	Operating Temperature	0 to +55	°C	1
T_{STG}	Storage Temperature	-40 to +85	°C	1
P_D	Power Dissipation	11.8	W	1, 2
I_{OUT}	Short Circuit Output Current	50	mA	1

1. Stresses greater than those listed may cause permanent damage to the device. This is a stress rating only, and device functional operation at or above the conditions indicated is not implied. Exposure to absolute maximum rating conditions for extended periods may affect reliability.
2. Maximum power occurs when all banks are active.

Recommended DC Operating Conditions ($T_A = 0$ to 55°C)

Symbol	Parameter	Min	Typ	Max	Units	Notes
V_{CC}	Supply Voltage	4.75	5.0	5.25	V	1
V_{IH}	Input High Voltage (\overline{RAS} & DATA)	2.4	—	$V_{CC} + 0.5$	V	1
	Input High Voltage (Redriven Signals)	2.0	—	V_{CC}	V	1
V_{IL}	Input Low Voltage (\overline{RAS} & DATA)	-0.5	—	0.8	V	1
	Input Low Voltage (Redriven Signals)	0.0	—	0.8	V	1

1. All voltages referenced to V_{SS} .

Capacitance ($T_A = 0$ to $+55^\circ\text{C}$, $V_{CC} = 5.0 \pm 0.25\text{V}$)

Symbol	Parameter	Max	Units	Notes
C_{I1}	Input Capacitance (A0~A9)	15	pF	
C_{I2}	Input Capacitance (\overline{RAS})	57	pF	
C_{I3}	Input Capacitance (CAS)	15	pF	
C_{I4}	Input Capacitance (\overline{WE})	20	pF	
$C_{I/O}$	Output Capacitance (DQ0~DQ34)	32	pF	

2M x 32 5.0V IC DRAM Card

DC Electrical Characteristics ($T_A = 0$ to $+55^\circ\text{C}$, $V_{CC} = 5.0 \pm 0.25\text{V}$)

Symbol	Parameter	Min	Max	Units	Notes	
I_{CC1}	Operating Current Average Power Supply Operating Current ($\overline{\text{RAS}}$, $\overline{\text{CAS}}$, Address Cycling: $t_{RC} = t_{RC \text{ min}}$)	-70	—	800	mA	
I_{CC2}	Standby Current (TTL) Power Supply Standby Current ($\overline{\text{RAS}} = \overline{\text{CAS}} \geq V_{IH}$)	—	32	mA	1, 3	
I_{CC3}	$\overline{\text{RAS}}$ Only Refresh Current Average Power Supply Current, $\overline{\text{RAS}}$ Only Mode ($\overline{\text{RAS}}$ Cycling, $\overline{\text{CAS}} \geq V_{IH}$: $t_{RC} = t_{RC \text{ min}}$)	-70	—	800	mA	
I_{CC4}	Fast Page Mode Current Average Power Supply Current, Fast Page Mode ($\overline{\text{RAS}} = V_{IL}$, $\overline{\text{CAS}}$, Address Cycling: $t_{PC} = t_{PC \text{ min}}$)	-70	—	800	mA	1, 2, 3
I_{CC5}	Standby Current (CMOS) Power Supply Standby Current ($\overline{\text{RAS}} = \overline{\text{CAS}} = V_{CC} - 0.2\text{V}$)	—	3.2	mA		
I_{CC6}	$\overline{\text{CAS}}$ Before $\overline{\text{RAS}}$ Refresh Current Average Power Supply Current, $\overline{\text{CAS}}$ Before $\overline{\text{RAS}}$ Mode ($\overline{\text{RAS}}$, $\overline{\text{CAS}}$, Cycling: $t_{RC} = t_{RC \text{ min}}$)	-70	—	800	mA	
I_{CC7}	Battery Backup Refresh Current Average Power Supply Current during Battery Backup refresh ($\overline{\text{CAS}} \leq V_{IL}$, $\overline{\text{WE}} \geq V_{IH}$, $t_{RAS} \leq 1\mu\text{Sec}$, $t_{RC} = 125\mu\text{Sec}$)		4.8	mA	1, 2	
I_{IL}	Input Leakage Current Input Leakage Current, any input ($0.0 \leq V_{IN} \leq (V_{CC} < 6.0\text{V})$) All Other Pins Not Under Test = 0V	$\overline{\text{RAS}}$	-40	+40	μA	
		$\overline{\text{CAS}}$, $\overline{\text{ADD}}$	-10	+10		
		$\overline{\text{WE}}$	-20	+20		
I_{OL}	Output Leakage Current (D_{OUT} is disabled, $0.0 \leq V_{OUT} \leq V_{CC}$)	-20	+20	μA		
V_{OH}	Output High Level Output "H" Level Voltage ($I_{OUT} = -2\text{mA}$ @ 2.4V)	2.4	—	V		
V_{OL}	Output Low Level Output "L" Level Voltage ($I_{OUT} = +2\text{mA}$ @ 0.4V)	—	0.4	V	4	

1. I_{CC1} , I_{CC3} , I_{CC4} and I_{CC6} depend on cycle rate.
2. I_{CC1} , I_{CC4} depend on output loading. Specified values are obtained with the output open.
3. Address can be changed once or less while $\overline{\text{RAS}} = V_{IL}$. In the case of I_{CC4} , it can be changed once or less when $\overline{\text{CAS}} = V_{IH}$
4. Refresh current is specified for the X32 configuration using One Bank

AC Characteristics ($T_A = 0$ to $+55^\circ\text{C}$, $V_{CC} = 5.0 \pm 0.25\text{V}$)

- V_{IH} (min) and V_{IL} (max) are reference levels for measuring timing of input signals. Transition times are measured between V_{IH} and V_{IL} .
- An initial pause of $100\mu\text{s}$ is required after power-up followed by 8 $\overline{\text{RAS}}$ only refresh cycles before proper device operation is achieved. In case of using internal refresh counter, a minimum of 8 $\overline{\text{CAS}}$ before $\overline{\text{RAS}}$ refresh cycles instead of 8 $\overline{\text{RAS}}$ only refresh cycles is required.
- The specified timings include buffer, loading and skew delays: 2ns minimum, 10ns ($\overline{\text{CAS}}$, $\overline{\text{WE}}$) or 11ns (Address) maximum delay, no pulse shrinkage. The data and $\overline{\text{RAS}}$ signals are not buffered, which preserves the DRAMs access specifications of 70ns
- AC measurements assume $t_T = 5\text{ns}$.

Read, Write, and Refresh Cycles (Common Parameters)

Symbol	Parameter	-70		Units	Notes
		Min	Max		
t_{RC}	Random Read or Write Cycle Time	130	—	ns	
t_{RP}	$\overline{\text{RAS}}$ Precharge Time	50	—	ns	
t_{CP}	$\overline{\text{CAS}}$ Precharge Time	10	—	ns	
t_{RAS}	$\overline{\text{RAS}}$ Pulse Width	70	10K	ns	
t_{CAS}	$\overline{\text{CAS}}$ Pulse Width	21	—	ns	2
t_{ASR}	Row Address Setup Time	11	—	ns	
t_{RAH}	Row Address Hold Time	10	—	ns	
t_{ASC}	Column Address Setup Time	3	—	ns	
t_{CAH}	Column Address Hold Time	17	—	ns	
t_{RCD}	$\overline{\text{RAS}}$ to $\overline{\text{CAS}}$ Delay Time	20	42	ns	2
t_{RAD}	$\overline{\text{RAS}}$ to Column Address Delay Time	15	24	ns	3
t_{RSH}	$\overline{\text{RAS}}$ Hold Time	29	—	ns	
t_{CSH}	$\overline{\text{CAS}}$ Hold Time	70	—	ns	
t_{CRP}	$\overline{\text{CAS}}$ to $\overline{\text{RAS}}$ Precharge Time	20	—	ns	
t_{DZC}	$\overline{\text{CAS}}$ Delay Time from D_{IN}	0	—	ns	
t_{AR}	Column Address Hold Time Referenced to $\overline{\text{RAS}}$	—	—	ns	4
t_T	Transition Time (Rise and Fall)	3	50	ns	

- The minimum t_{CAS} requires t_{CSH} to be met for both writes and reads. Also, because of the buffer, the minimum t_{CAS} for a read cycle must be extended to guarantee the data out window (t_{OH}) in the application. For example, a t_{CAS} of 21ns plus a minimum t_{OH} of 2ns would result in turning data out of the card at 23ns (6ns before max t_{CAC} of 29ns).
- Operation within the t_{RCD} (max) limit ensures that t_{RAC} (max) can be met. t_{RCD} (max) is specified as a reference point only: if t_{RCD} is greater than the specified t_{RCD} (max) limit, then access time is controlled by t_{CAC} .
- Operation within the t_{RAD} (max) limit ensures that t_{RAC} (max) can be met. t_{RAD} (max) is specified as a reference point only: If t_{RAD} is greater than the specified t_{RAD} (max) limit, then access time is controlled by t_{AA} .
- This timing parameter is not applicable to this product, but may apply to a related product in this family.

2M x 32 5.0V IC DRAM Card
Write Cycle

Symbol	Parameter	-70		Units	Notes
		Min	Max		
t_{WCS}	Write Command Set Up Time	2	—	ns	
t_{WCH}	Write Command Hold Time	15	—	ns	
t_{WP}	Write Command Pulse Width	16	—	ns	
t_{RWL}	Write Command to \overline{RAS} Lead Time	—	—	ns	1
t_{CWL}	Write Command to \overline{CAS} Lead Time	—	—	ns	1
t_{WCR}	Write Command Hold Time Referenced to \overline{RAS}	—	—	ns	1
t_{DHR}	Data Hold Time Referenced to \overline{RAS}	—	—	ns	1
t_{DS}	D_{IN} Setup Time	0	—	ns	
t_{DH}	D_{IN} Hold Time	25	—	ns	

1. This timing parameter is not applicable to this product, but may be applicable to a related product in this family.

Read Cycle

Symbol	Parameter	-70		Units	Notes
		Min	Max		
t_{RAC}	Access Time from \overline{RAS}	—	70	ns	1, 2
t_{CAC}	Access Time from \overline{CAS}	—	29	ns	1, 2
t_{AA}	Access Time from Address	—	46	ns	1, 2
t_{RCS}	Read Command Setup Time	2	—	ns	
t_{RCH}	Read Command Hold Time to \overline{CAS}	0	—	ns	3
t_{RRH}	Read Command Hold Time to \overline{RAS}	0	—	ns	3
t_{RAL}	Column Address to \overline{RAS} Lead Time	46	—	ns	
t_{CAL}	Column Address to \overline{CAS} Lead Time	—	—	ns	4
t_{CLZ}	\overline{CAS} to Output in Low-Z	2	—	ns	
t_{OH}	Output Data Hold Time	2	—	ns	
t_{CDD}	\overline{CAS} to D_{IN} Delay Time	29	—	ns	
t_{OFF}	Output Buffer Turn-off Delay	2	29	ns	5

1. Access time is determined by the later of t_{RAC} , t_{CAC} , t_{AA} or t_{CPA} .
2. Measured with two TTL loads and 100pF.
3. Either t_{RCH} or t_{RRH} must be satisfied for a read cycle.
4. This timing parameter is not applicable to this product, but may be applicable to a related product in this family.
5. t_{OFF} (max) defines the time at which the output achieves the open circuit condition and is not referenced to output voltage levels.

Fast Page Mode Cycle

Symbol	Parameter	-70		Units	Notes
		Min	Max		
t_{PC}	Fast Page Mode Cycle Time	50	—	ns	
t_{RASP}	Fast Page Mode \overline{RAS} Pulse Width	70	10K	ns	
t_{CPRH}	\overline{RAS} Hold Time from \overline{CAS} Precharge	49	—	ns	
t_{CPA}	Access Time from \overline{CAS} Precharge	—	49	ns	1, 2

1. Access time is determined by the latter of t_{RAC} , t_{CAC} , t_{CPA} , t_{AA} .
 2. Access time assumes a load of 100pf.

Refresh Cycle

Symbol	Parameter	-70		Units	Notes
		Min	Max		
t_{CHR}	\overline{CAS} Hold Time (\overline{CAS} before \overline{RAS} Refresh Cycle)	13	—	ns	
t_{CSR}	\overline{CAS} Setup Time (\overline{CAS} before \overline{RAS} Refresh Cycle)	20	—	ns	
t_{WRP}	\overline{WE} Setup Time (\overline{CAS} before \overline{RAS} Refresh Cycle)	20	—	ns	
t_{WRH}	\overline{WE} Hold Time (\overline{CAS} before \overline{RAS} Refresh Cycle)	8	—	ns	
t_{RPC}	\overline{RAS} Precharge to \overline{CAS} Hold Time	8	—	ns	
t_{REF}	Refresh Period	—	128	ms	1

1. 1024 refreshes are required every 128ms.

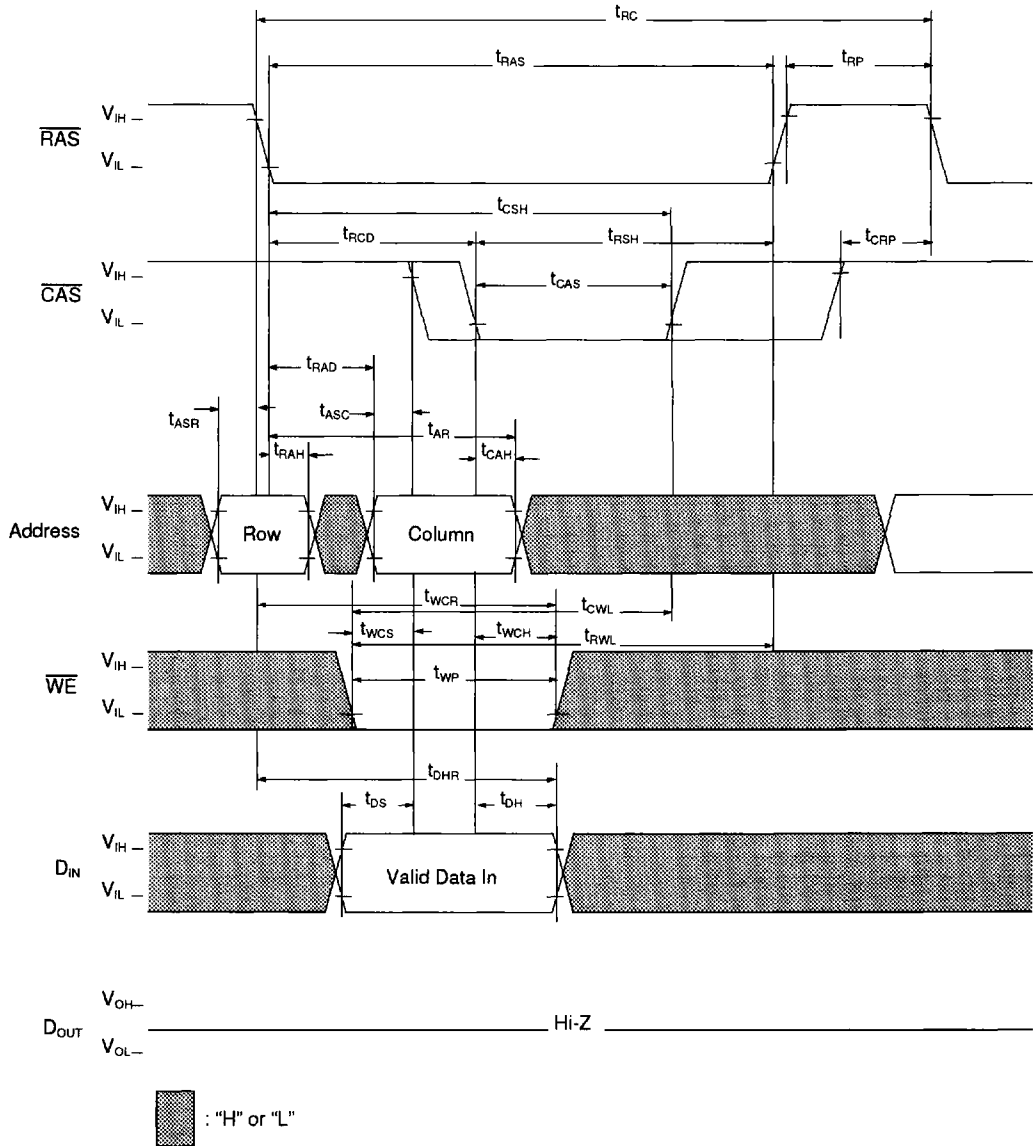
Write Cycle (Early Write)

Fast Page Mode Read Cycle

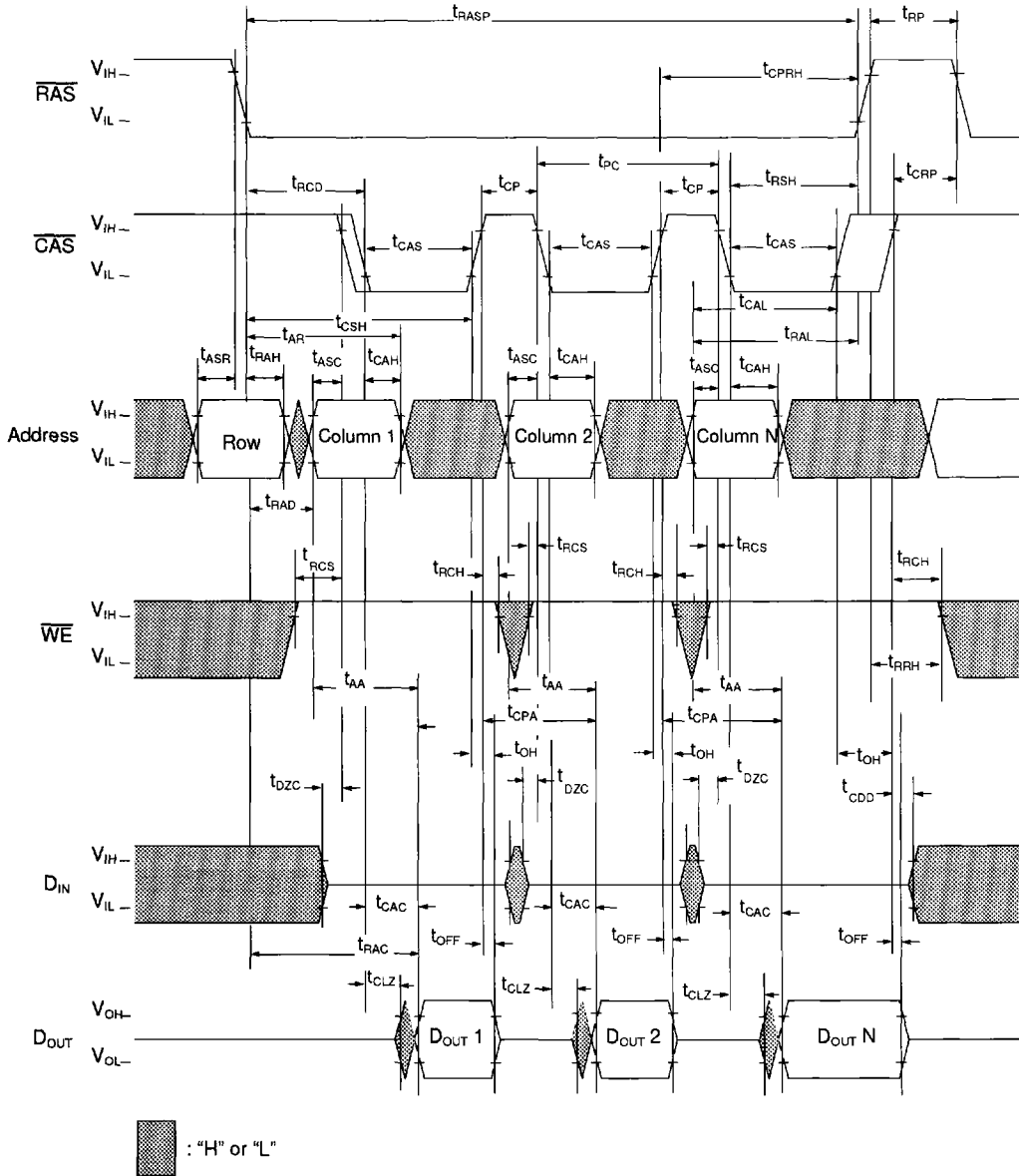

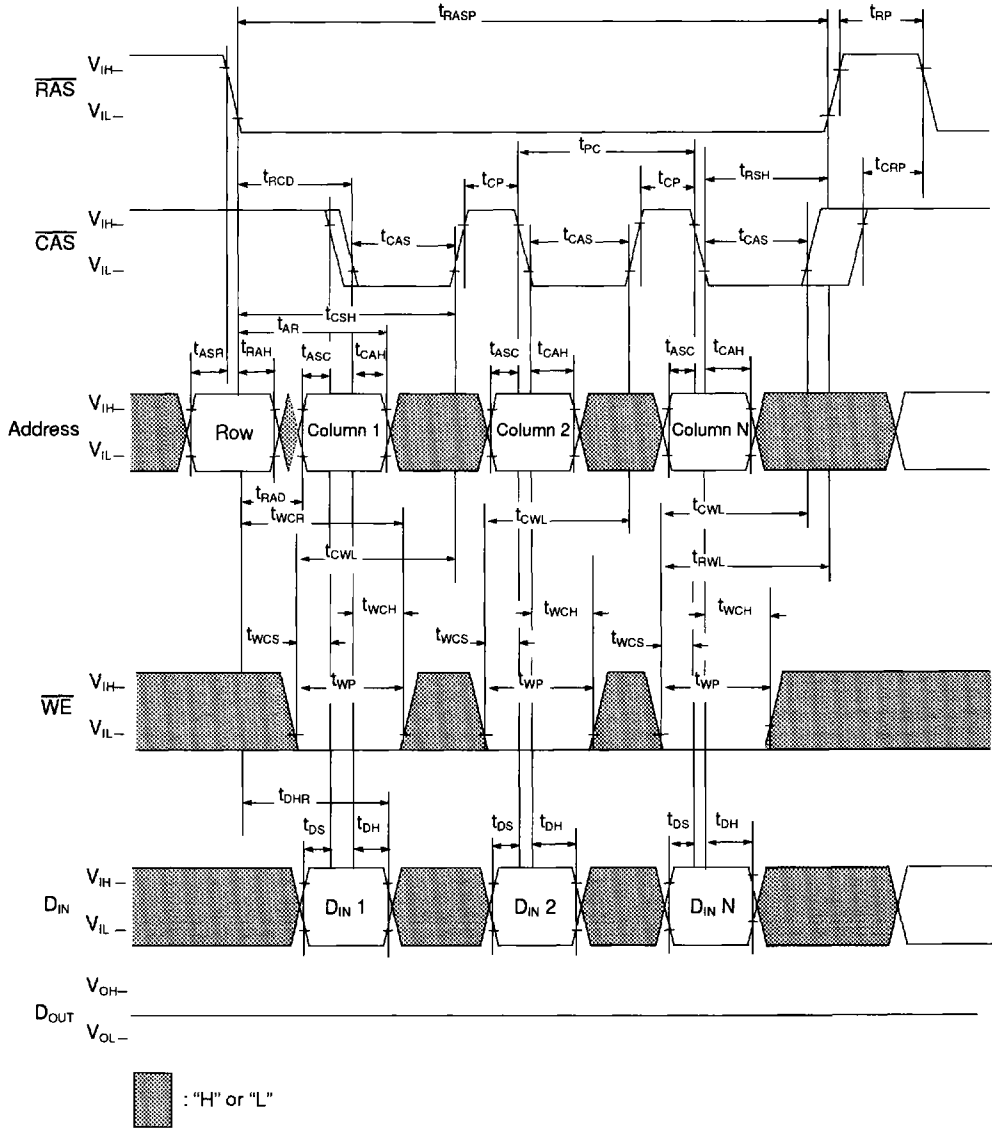
Fast Page Mode Write Cycle

RAS Only Refresh Cycle

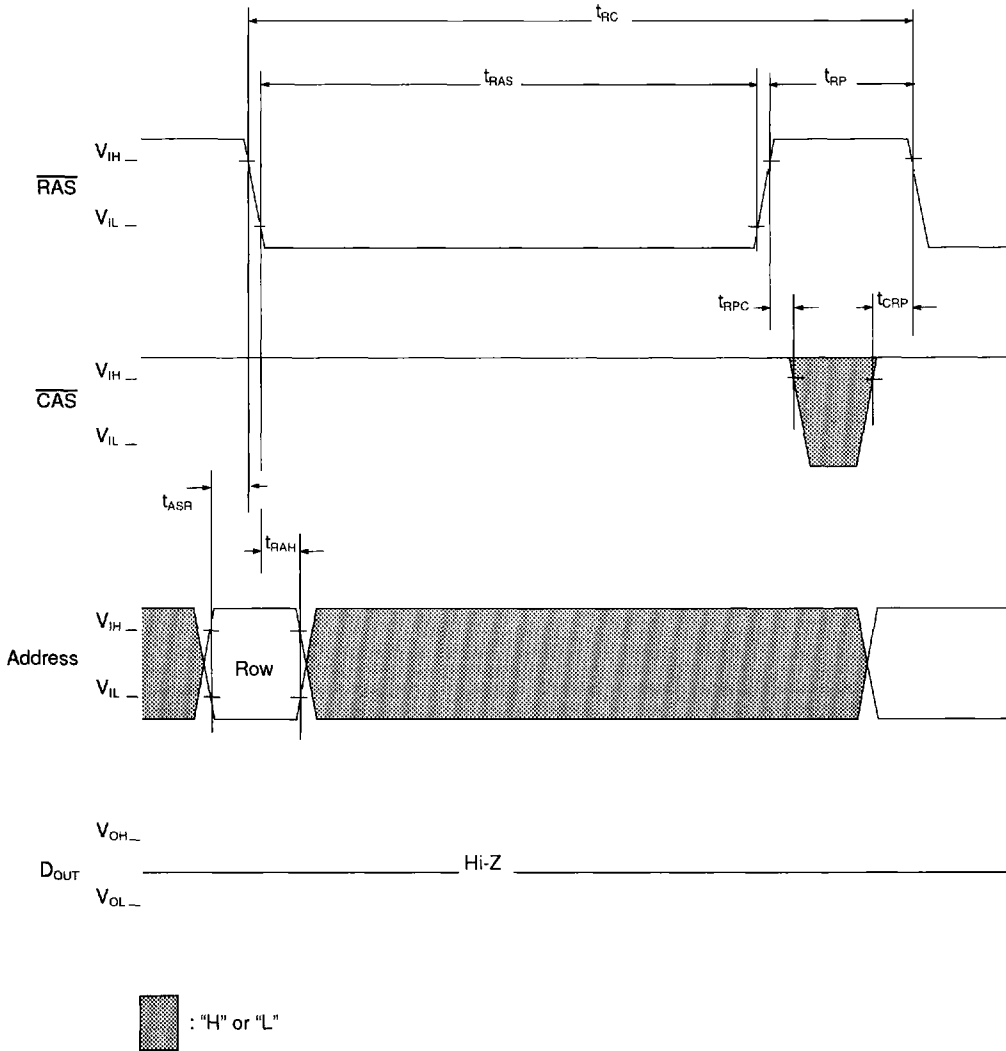

Note: $\overline{\text{WE}}$, D_{IN} are "H" or "L"

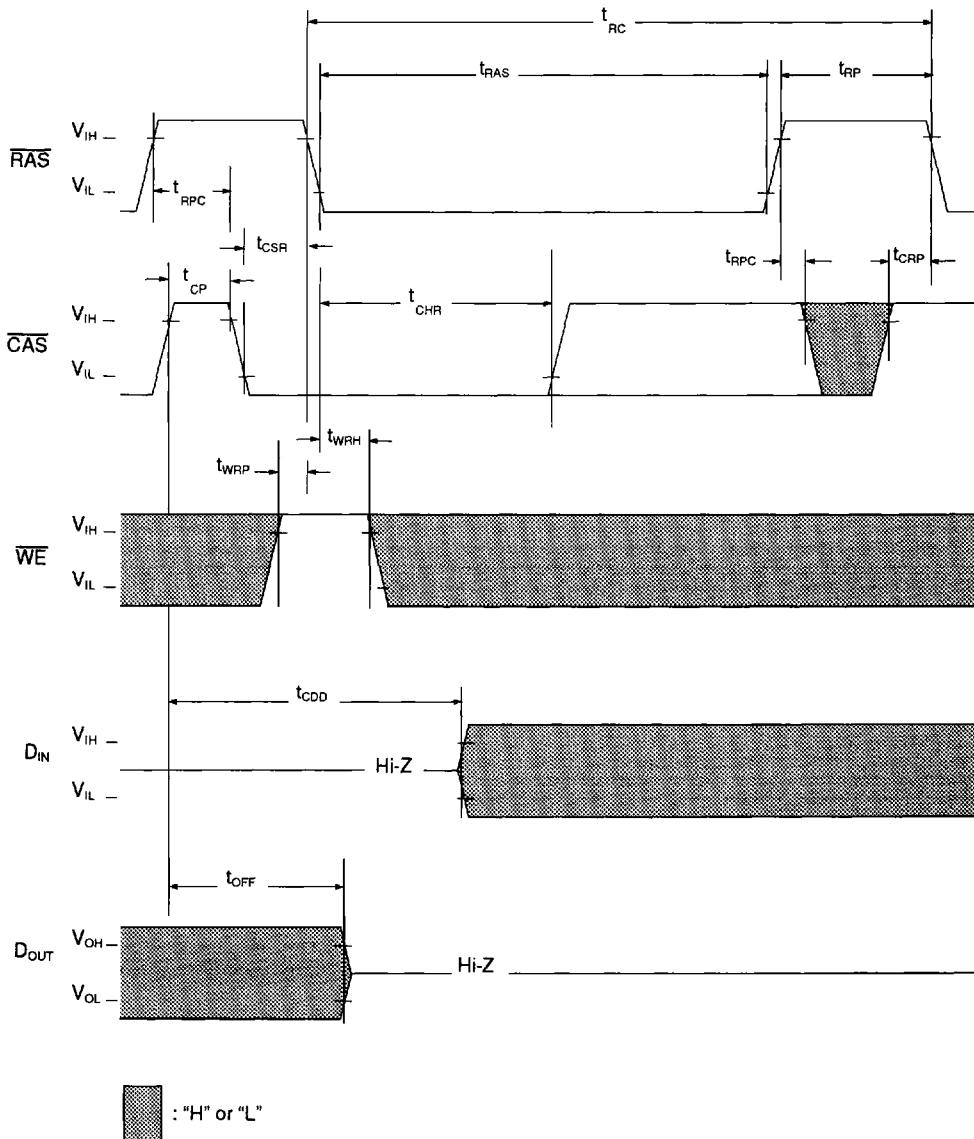
CAS Before RAS Refresh Cycle

Note: Addresses are "H" or "L"

2M x 32 5.0V IC DRAM Card

Layout Drawing

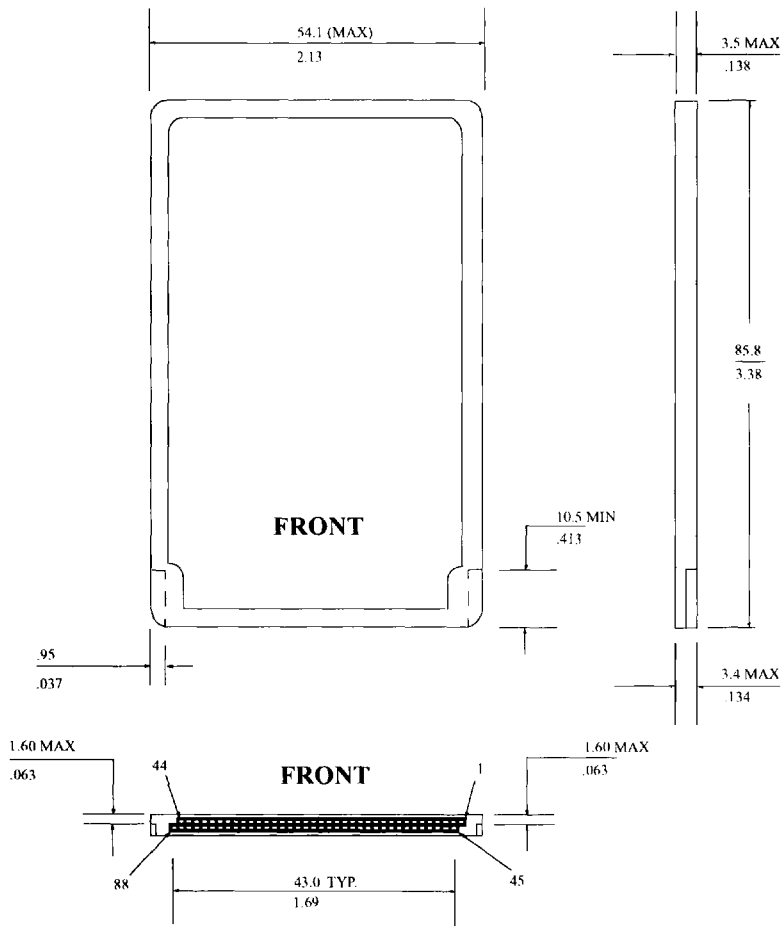

NOTE: All dimensions are typical unless otherwise stated. $\frac{\text{MILLIMETERS}}{\text{INCHES}}$