

DESCRIPTION:

The DPS128M8CnY/BnY, DPS128X8CA3/BA3 High Speed SRAM devices are a revolutionary new memory subsystem using Dense-Pac Microsystems' ceramic Stackable Leadless Chip Carriers (SLCC). Available in straight leaded, "J" leaded or gullwing leaded packages, or mounted on a 50-pin PGA co-fired ceramic substrate. These devices pack 1-Megabits of low-power CMOS static RAM in an area as small as 0.463 in², while maintaining a total height as low as 0.082 inches.

The SLCC devices contain an individual 128K x 8 SRAMs, each packaged in a hermetically sealed SLCC, making the modules suitable for commercial, industrial and military applications.

The DPS128M8BnY/DPS128X8BA3 has one active low Chip Enable (\overline{CE}) while the DPS128M8CnY/DPS128X8CA3 has an active low Chip Enable (\overline{CE}) and an active high Select Line (SEL).

By using SLCCs, the "Stack" family of modules offer a higher board density of memory than available with conventional through-hole, surface mount or hybrid techniques.

FEATURES:

- Organization Available: 128Kx8
- Access Times: 20*, 25, 30, 35, 45ns
- Fully Static Operation - No clock or refresh required
- Single +5V Power Supply, $\pm 10\%$ Tolerance
- TTL Compatible
- Common Data Inputs and Outputs
- Low Data Retention Voltage: 2.0V min.
- Packages Available:
 - 48 - Pin SLCC
 - 48 - Pin Straight Leaded SLCC
 - 48 - Pin "J" Leaded SLCC
 - 48 - Pin Gullwing Leaded SLCC
 - 50 - Pin PGA Dense-Stack

* Commercial only.

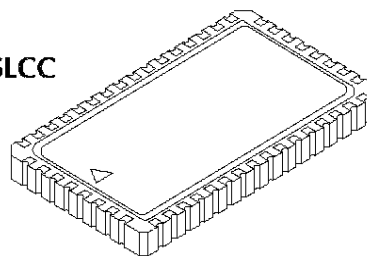
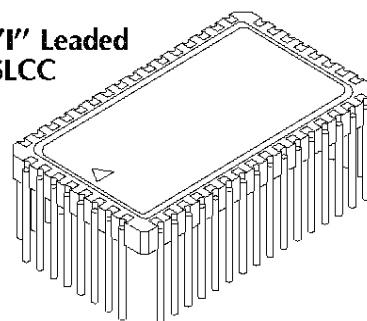
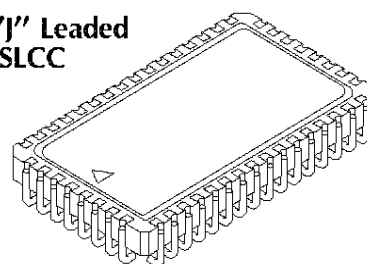
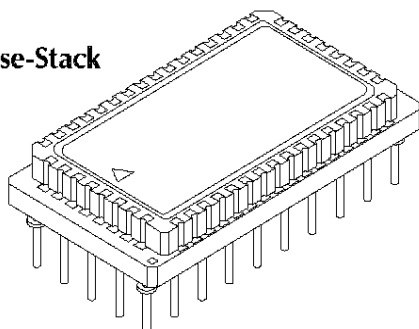
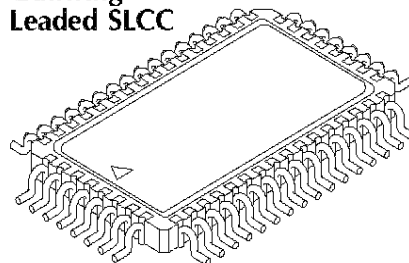
SLCC**"J" Leaded SLCC****"J" Leaded SLCC****Dense-Stack****Gullwing Leaded SLCC**

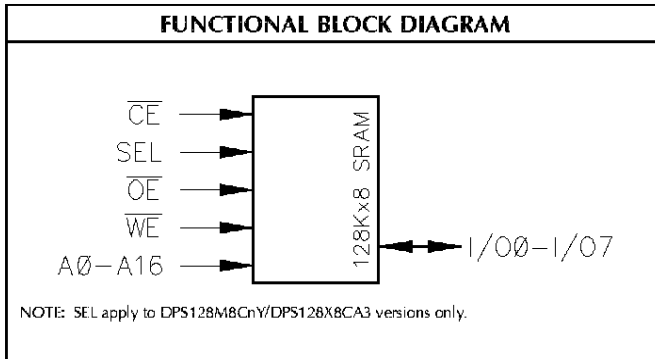

PIN NAMES	
A0 - A16	Address Inputs
I/O0 - I/O7	Data Input/Output
\overline{CE}	Low Chip Enable
SEL	High Chip Enable
\overline{WE}	Write Enable
\overline{OE}	Output Enable
V _{DD}	Power (+ 5V)
V _{SS}	Ground
N.C.	No Connect

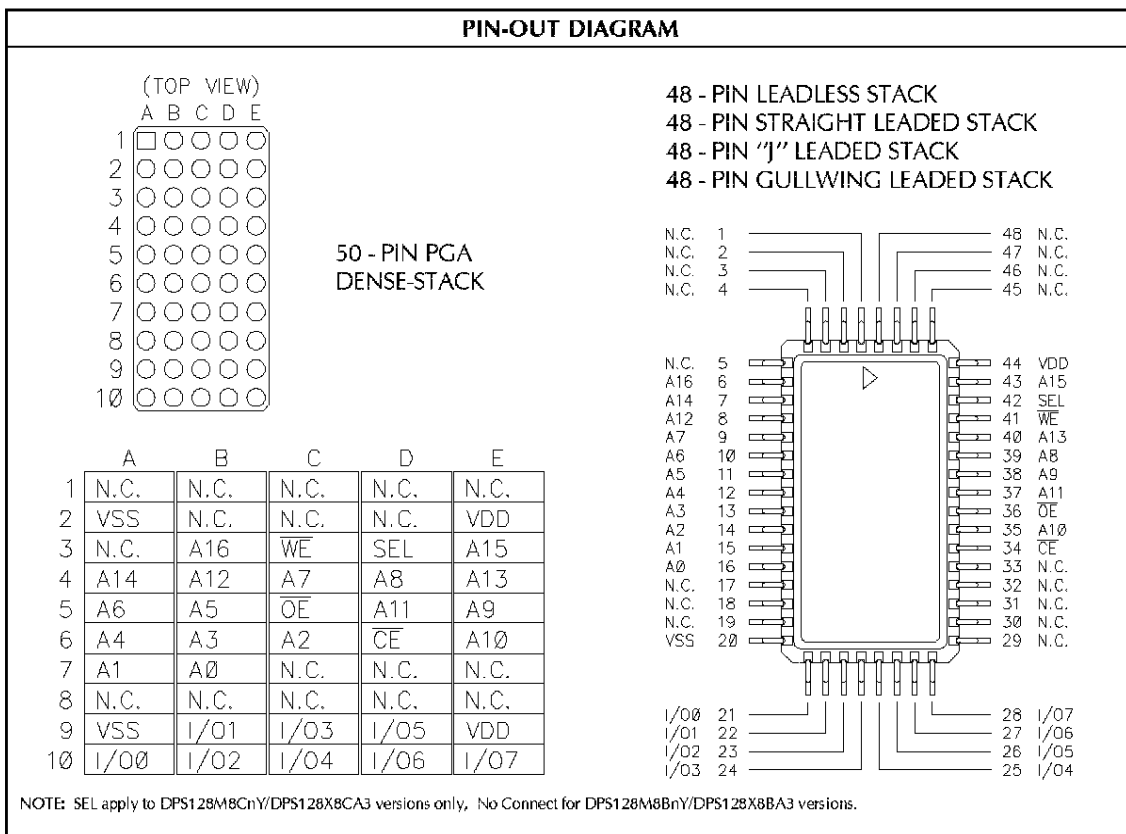

RECOMMENDED OPERATING RANGE ³						
Symbol	Characteristic	Min.	Typ.	Max.	Unit	
V _{DD}	Supply Voltage	4.5	5.0	5.5	V	
V _{IH}	Input HIGH Voltage	2.2		V _{DD} +0.3	V	
V _{IL}	Input LOW Voltage	-0.5 ²		0.8	V	
T _A	Operating Temperature	M/B	-55	+25	+125	°C
		I	-40	+25	+85	
		C	0	+25	+70	

TRUTH TABLE						
Mode	SEL	CE	WE	OE	I/O Pin	Supply Current
Not Selected	L	X	X	X	High-Z	Standby
Not Selected	X	H	X	X	High-Z	Standby
DOUT Disable	H	L	H	H	High-Z	Active
Read	H	L	H	L	D _{OUT}	Active
Write	H	L	L	X	D _{IN}	Active

H = HIGH L = LOW X = Don't Care
 NOTE: SEL applies to DPS128M8CnY/DPS128X8CA3 version only.

DC OUTPUT CHARACTERISTICS					
Symbol	Parameter	Conditions	Min.	Max.	Unit
V _{OH}	HIGH Voltage	I _{OH} = -4.0mA	2.4		V
V _{OL}	LOW Voltage	I _{OL} = 8.0mA		0.4	V

CAPACITANCE ⁴ : T _A = 25°C, F = 1.0MHz				
Symbol	Parameter	Max.	Unit	Condition
C _{ADR}	Address Input	10	pF	V _{IN} ² = 0V
C _{CE}	Chip Enable	10		
C _{SEL}	Active High Chip Select	10		
C _{WE}	Write Enable	10		
C _{OE}	Output Enable	10		
C _{I/O}	Data Input/Output	14		

NOTE: C_{SEL} applies to DPS128M8CnY/DPS128X8CA3 version only.

ABSOLUTE MAXIMUM RATINGS ³			
Symbol	Parameter	Value	Unit
T _{STC}	Storage Temperature	-65 to +150	°C
T _{BIAS}	Temperature Under Bias	-55 to +125	°C
V _{DD}	Supply Voltage ¹	-0.5 to +7.0	°C
V _{I/O}	Input/Output Voltage ¹	-0.5 to V _{DD} +0.5	V

DC OPERATING CHARACTERISTICS: Over operating ranges										
Symbol	Characteristics	Test Conditions	Typ. (†)	C		I		M/B		Unit
				Min.	Max.	Min.	Max.	Min.	Max.	
I _{IN}	Input Leakage Current	V _{IN} = 0V to V _{DD}	-	-5	+5	-5	+5	-5	+5	µA
I _{OUT}	Output Leakage Current	V _{I/O} = 0V to V _{DD} , CE or OE = V _{IH} , or WE = V _{IL}	-	-10	+10	-10	+10	-10	+10	µA
I _{CC}	Operating Supply Current	Cycle = min., Duty = 100% I _{OUT} = 0mA	100		140		140		160	mA
I _{SB1}	Full Standby Supply Current	V _{IN} ≥ V _{DD} - 0.2V or V _{IN} ≤ V _{SS} + 0.2V	0.4		5		5		10	mA
I _{SB2}	Standby Current (TTL)	CE = V _{IH}	25		30		35		35	mA
I _{DR3}	Data Retention Supply Current (3.0V)	V _{DR} = 3.0V, CE ≥ V _{DR} - 0.2V, (or SEL ≤ 0.2V, V _{IN} ≥ V _{DD} - 0.2V or V _{IN} ≤ +0.2V)	70		400		600		2000	µA
I _{DR2}	Data Retention Supply Current (2.0V)	V _{DR} = 2.0V, CE ≥ V _{DR} - 0.2V, (or SEL ≤ 0.2V, V _{IN} ≥ V _{DD} - 0.2V or V _{IN} ≤ +0.2V)	35		250		400		1800	µA
V _{OL}	Output Low Voltage	I _{OUT} = 8.0mA	-		0.4		0.4		0.4	V
V _{OH}	Output High Voltage	I _{OUT} = -4.0mA	-	2.4		2.4		2.4		V

† Typical measurements made at +25°C, Cycle = min., V_{DD} = 5.0V.
 NOTE: Test Conditions in parenthesis apply to DPS128M8CnY/DPS128X8CA3 version only.

AC TEST CONDITIONS	
Input Pulse Levels	0V to 3.0V
Input Pulse Rise and Fall Times	5ns
Input and Output Timing Reference Levels	1.5V

OUTPUT LOAD		
Load	C _L	Parameters Measured
1	100pF	except t _{LZ1} , t _{LZ2} , t _{HZ1} , t _{HZ2} , t _{OHZ} , t _{OLZ} , and t _{WHZ}
2	5pF	t _{LZ1} , t _{LZ2} , t _{HZ1} , t _{HZ2} , t _{OHZ} , t _{OLZ} , and t _{WHZ}

NOTE: t_{LZ2} and t_{HZ2} apply to DPS128M8CnY/DPS128X8CA3 version only.

Figure 1. Output Load

* Including Probe and Jig Capacitance.

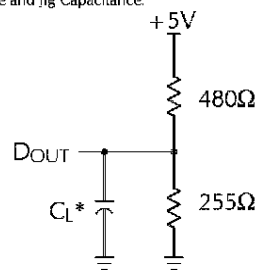

Data Retention AC Characteristics ⁸						
Symbol	Parameter	Test Conditions	Min.	Typ.	Max.	Unit
V _{DR}	V _{DD} for Data Retention	$\overline{CE} \geq V_{DR} - 0.2V$, (SEL $\geq V_{DR} - 0.2V$, or V _{IN} $\leq V_{DR} - 0.2V$ or V _{IN} $\leq 0.2V$)	2.0	-	-	V
V _{CDR}	Chip Disable to Data Retention Time	See Data Retention Waveform	0	-	-	ns
t _r	Operation Recovery Time	See Data Retention Waveform	5	-	-	ms

NOTE: Test Conditions in parenthesis apply to DPS128M8CnY/DPS128X8CA3 version only.

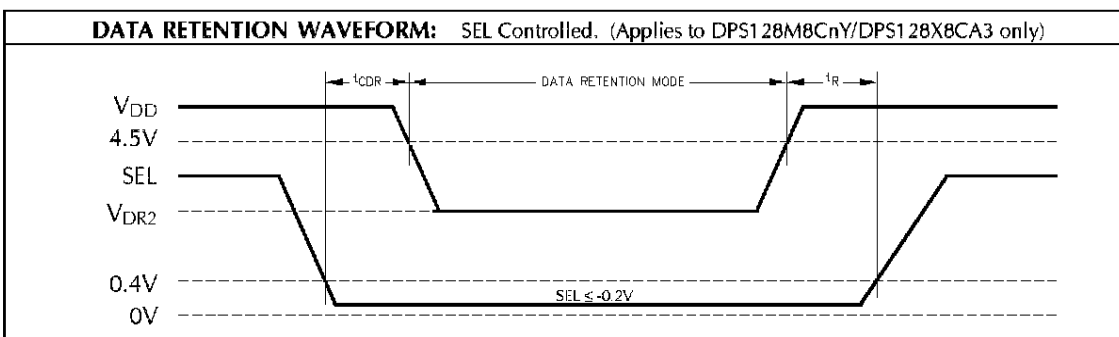
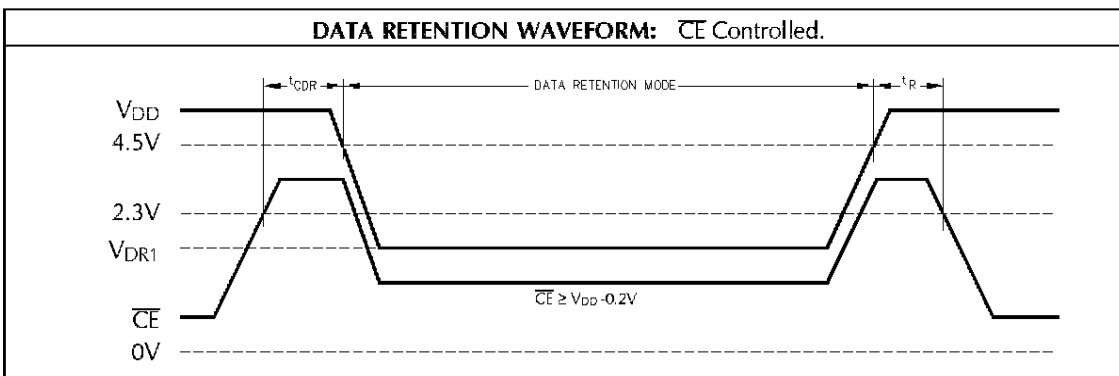

AC OPERATING CONDITIONS AND CHARACTERISTICS - READ CYCLE: Over operating ranges													
No.	Symbol	Parameter	20ns*		25ns		30ns		35ns		45ns		Unit
			Min.	Max.	Min.	Max.	Min.	Max.	Min.	Max.	Min.	Max.	
1	t _{RC}	Read Cycle Time	20		25		30		35		45		ns
2	t _{AA}	Address Access Time		20		25		30		35		45	ns
3	t _{CO1}	\overline{CE} to Output Valid		20		25		30		35		45	ns
4	t _{CO2}	SEL to Output Valid		20		25		30		35		45	ns
5	t _{OE}	Output Enable to Output Valid		8		10		15		20		25	ns
6	t _{LZ1}	\overline{CE} to Output in LOW-Z ^{4,5}	3		3		3		3		3		ns
7	t _{LZ2}	SEL to Output in LOW-Z ^{4,5}	3		3		3		3		3		ns
8	t _{OLZ}	Output Enable to Output in LOW-Z ^{4,5}	0		0		0		0		0		ns
9	t _{HZ1}	\overline{CE} to Output in HIGH-Z ^{4,5}		10		12		15		20		25	ns
10	t _{HZ2}	SEL to Output in HIGH-Z ^{4,5}		10		12		15		20		25	ns
11	t _{OHZ}	Output Enable to Output in HIGH-Z ^{4,5}		8		10		15		20		25	ns
12	t _{OH}	Output Hold from Address Change	3		3		3		3		3		ns

* Available in Commercial Only.

NOTE: t_{CO2}, t_{LZ2} and t_{HZ2} apply to DPS128M8CnY/DPS128X8CA3 version only.

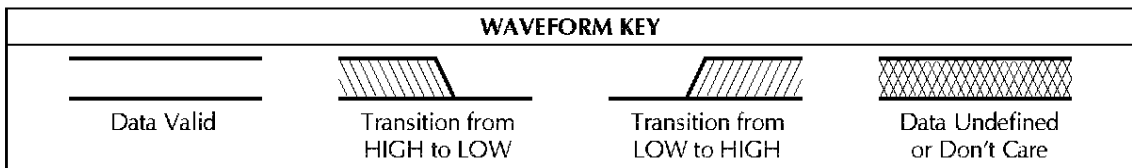
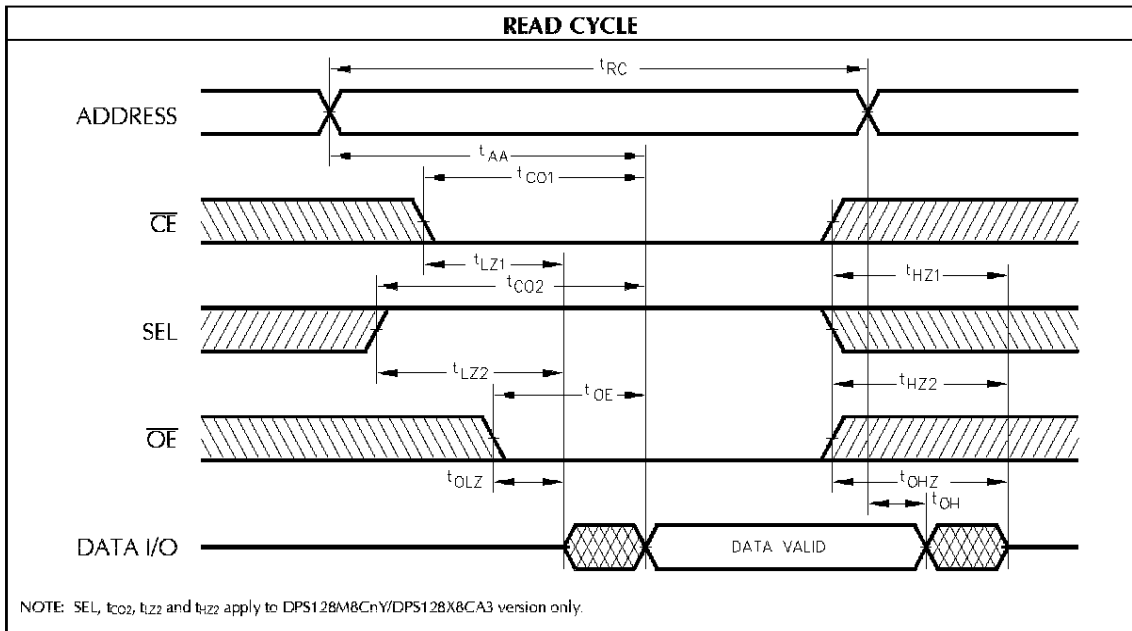

AC OPERATING CONDITIONS AND CHARACTERISTICS - WRITE CYCLE ^{6,7} ; Over operating ranges													
No.	Symbol	Parameter	20ns*		25 ns		30ns		35 ns		45 ns		Unit
			Min.	Max.	Min.	Max.	Min.	Max.	Min.	Max.	Min.	Max.	
13	t _{WC}	Write Cycle Time	20		25		30		35		45		ns
14	t _{AW}	Address Valid to End of Write	15		20		25		30		40		ns
15	t _{CW}	Chip Enable to End of Write	15		20		25		30		40		ns
16	t _{AS}	Address Set-Up Time **	0		0		0		0		0		ns
17	t _{WP}	Write Pulse Width	15		20		25		30		35		ns
18	t _{WR}	Write Recovery Time	0		0		0		0		0		ns
19	t _{WHZ}	Write Enable to Output in HIGH-Z ^{4,5}		8		10		12		15		20	ns
20	t _{DW}	Data to Write Time Overlap	12		15		15		20		25		ns
21	t _{DH}	Data Hold from Write Time	0		0		0		0		0		ns
22	t _{OW}	Output Active from End of Write	3		3		3		3		3		ns

* Available in Commercial Only.

** Valid for both Read and Write Cycles.

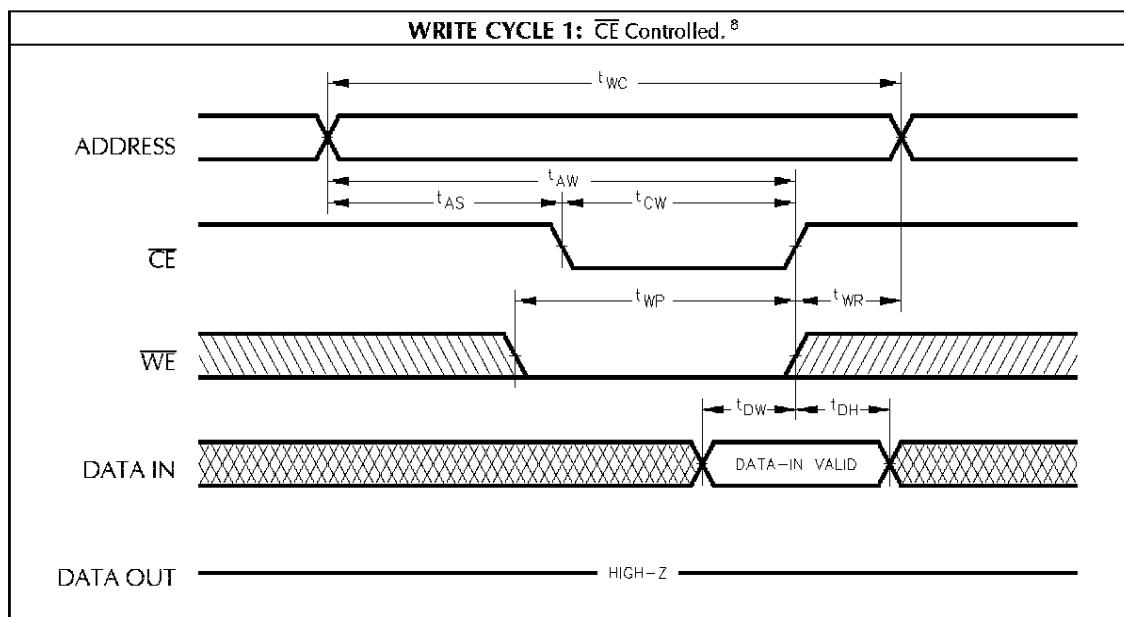

NOTES:

1. All voltages are with respect to V_{SS}.
2. -2.0V min. for pulse width less than 20ns (V_{IL} min. = -0.5V at DC level).
3. Stresses greater than those under ABSOLUTE MAXIMUM RATINGS may cause permanent damage to the device. This is a stress rating only and functional operation of the device at these or any other conditions above those indicated in the operational sections of this specification is not implied. Exposure to absolute maximum rating conditions for extended periods may affect reliability.
4. This parameter is guaranteed and not 100% tested.
5. Transition is measured at the point of ±500mV from steady state voltage.
6. When \overline{OE} and \overline{CE} are LOW and \overline{WE} is HIGH, I/O pins are in the output state, and input signals of opposite phase to the outputs must not be applied.
7. The outputs are in a high impedance state when \overline{WE} is LOW.
8. SEL timing is the same as \overline{CE} timing (Valid for DPS128M8CnY/DPS128CA3 only). The Waveform is inverted.
9. Chip Enable and Write Enable can initiate and terminate WRITE Cycle.

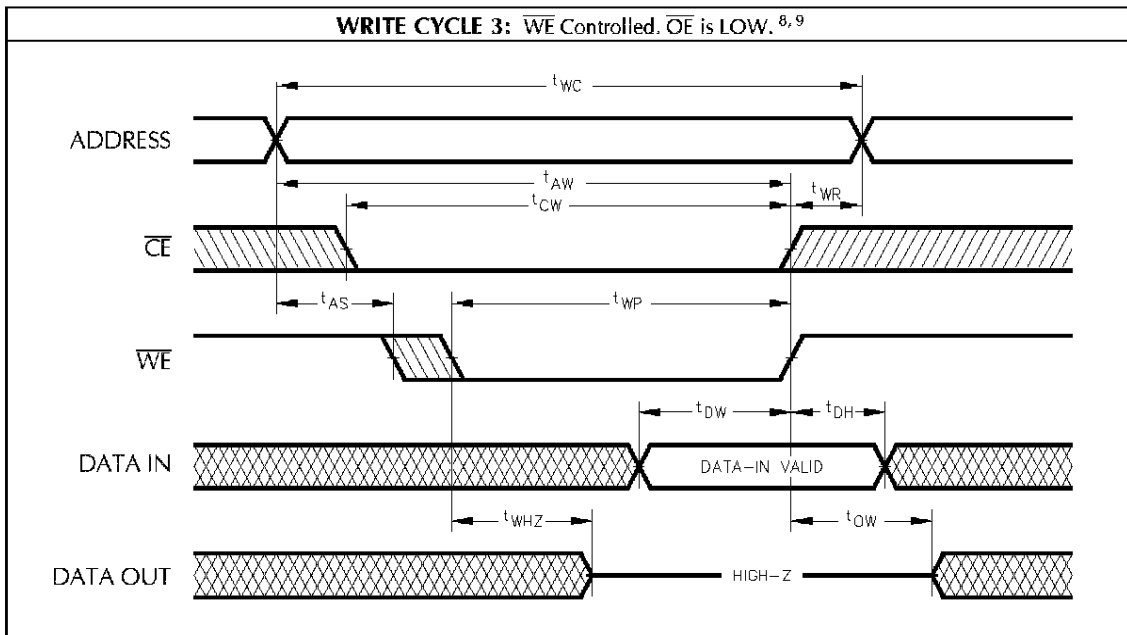
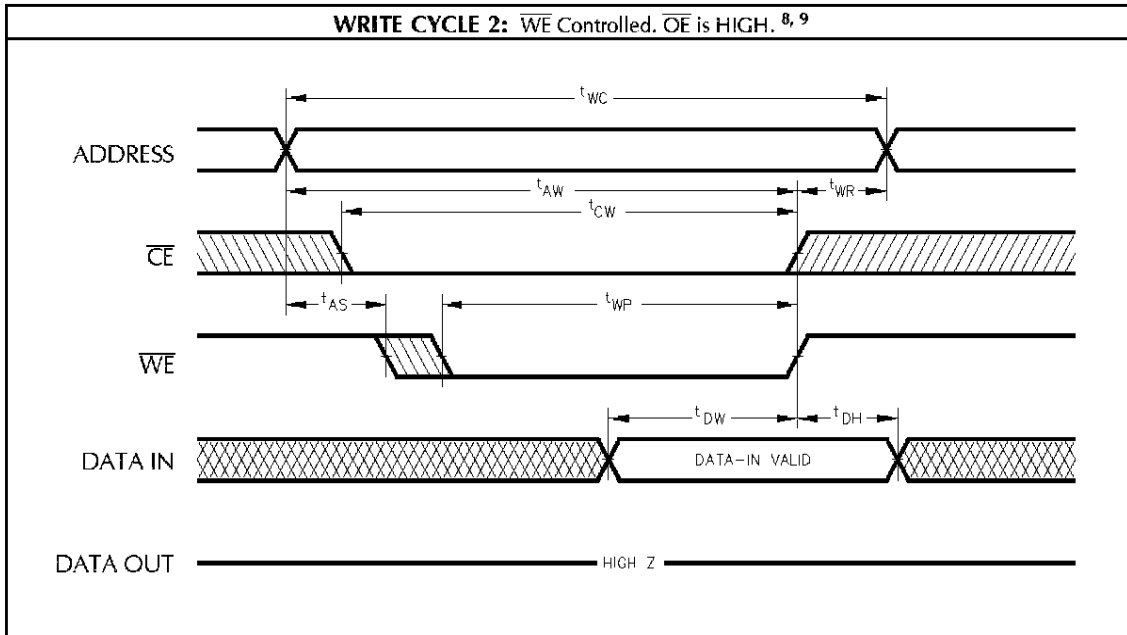

(48 - PIN LEADLESS SLCC) MECHANICAL DRAWING

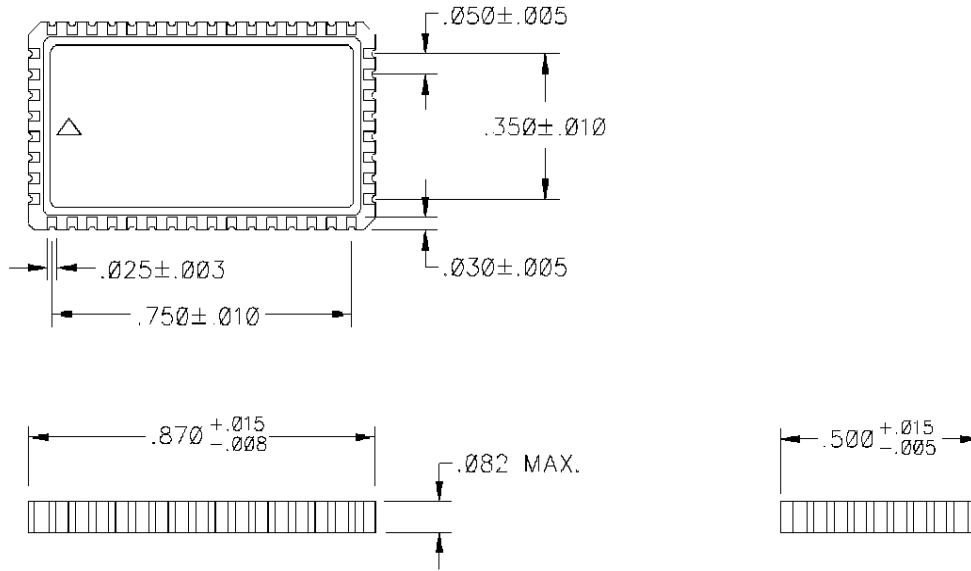

(48 - PIN STRAIGHT LEADED SLCC) MECHANICAL DRAWING

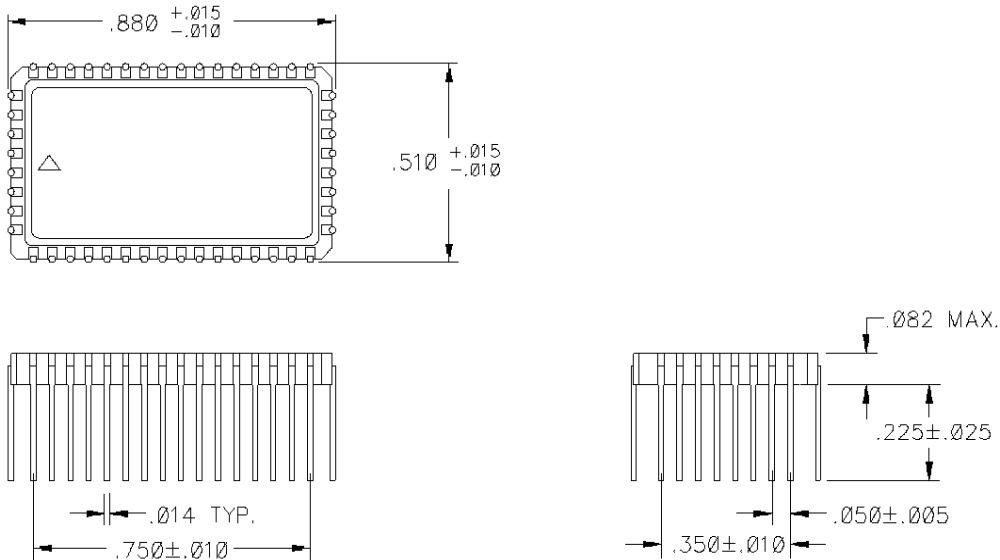

(48 - PIN "J" LEADED SLCC) MECHANICAL DRAWING

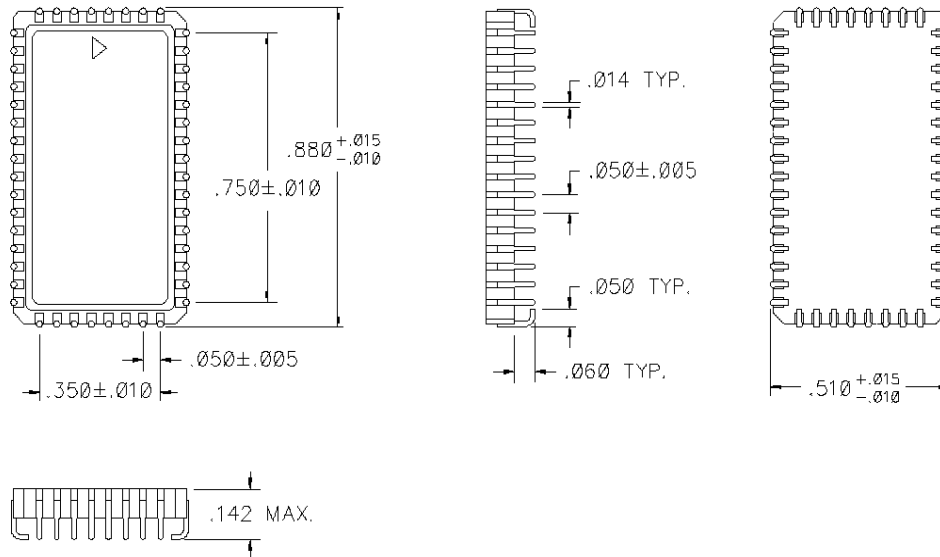

(48 - PIN GULLWING LEADED SLCC) MECHANICAL DRAWING

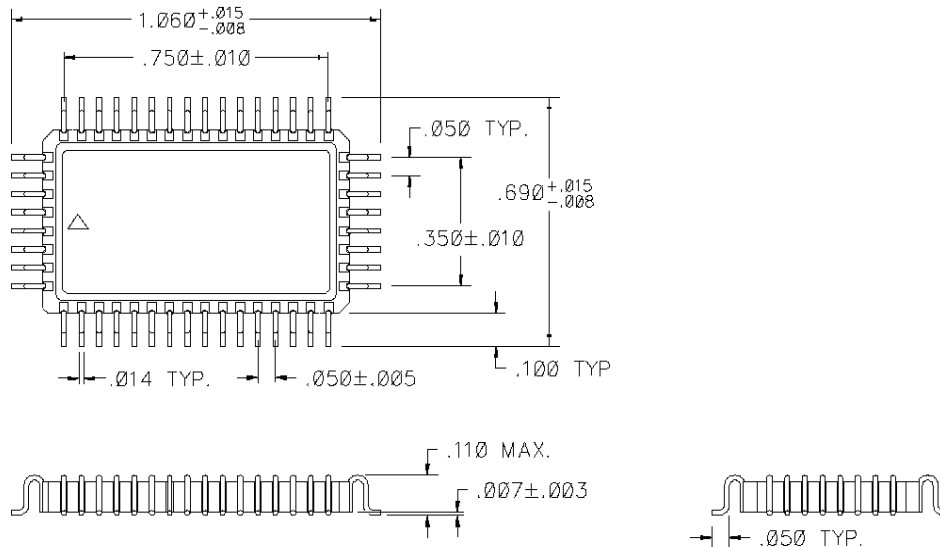

(50 - PIN PGA) MECHANICAL DRAWING

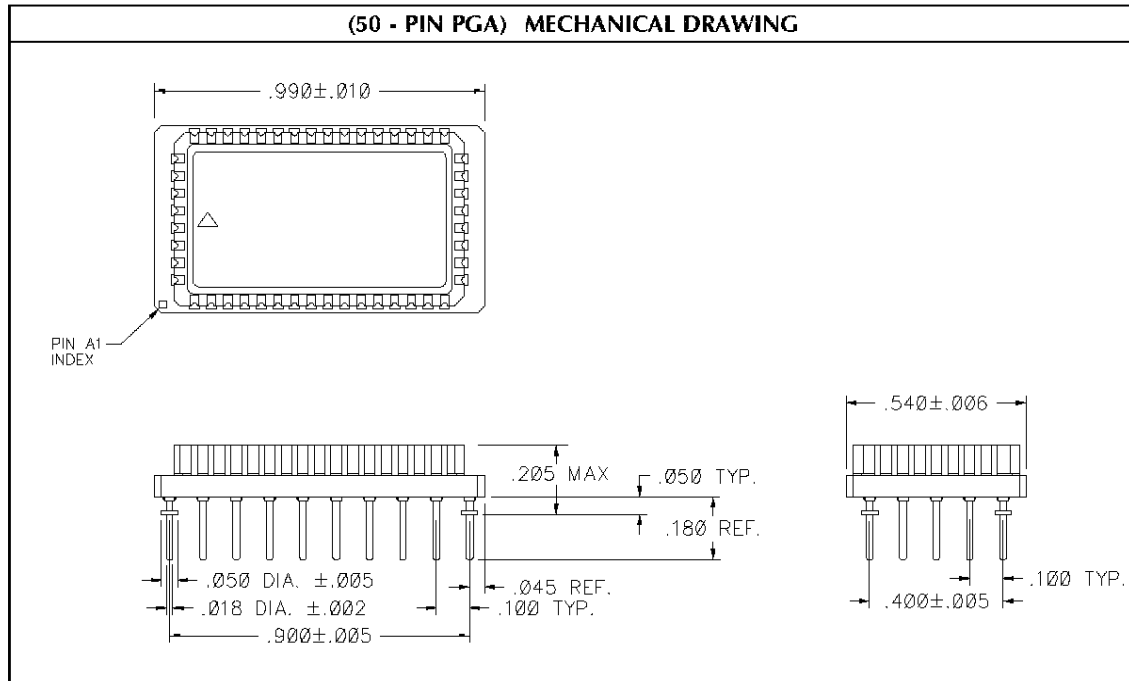

ORDERING INFORMATION

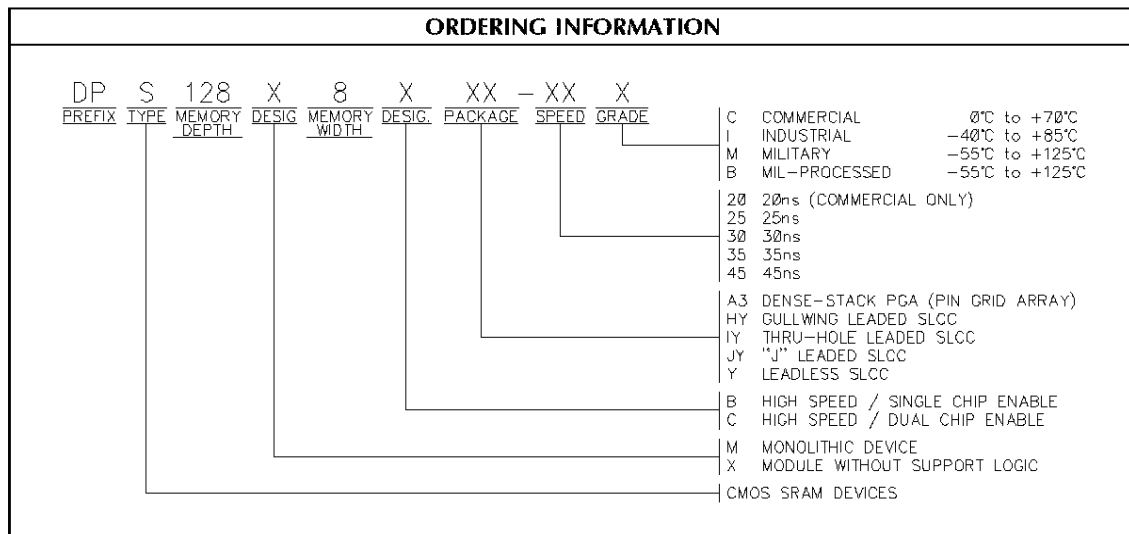

Dense-Pac Microsystems, Inc.

7321 Lincoln Way ♦ Garden Grove, California 92841-1428

(714) 898-0007 ♦ (800) 642-4477 (Outside CA) ♦ FAX: (714) 897-1772 ♦ <http://www.dense-pac.com>