

FEATURES

- High Output Power: $P_{1dB} = 38.5\text{dBm}$ (Typ.)
- High Gain: $G_{1dB} = 10.0\text{dB}$ (Typ.)
- High PAE: $\eta_{add} = 37\%$ (Typ.)
- Low $IM_3 = -46\text{dBc}$ @ $P_o = 27.5\text{dBm}$
- Broad Band: 5.9 ~ 6.4GHz
- Impedance Matched $Z_{in}/Z_{out} = 50\Omega$
- Hermetically Sealed Package

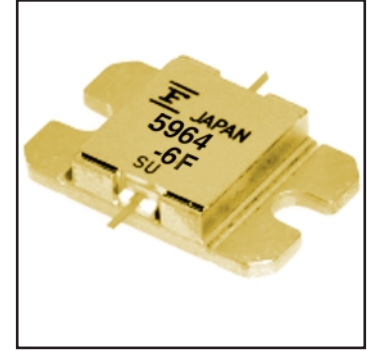

DESCRIPTION

The FLM5964-6F is a power GaAs FET that is internally matched for standard communication bands to provide optimum power and gain in a 50 ohm system.

Fujitsu's stringent Quality Assurance Program assures the highest reliability and consistent performance.

ABSOLUTE MAXIMUM RATING (Ambient Temperature $T_a=25^\circ\text{C}$)

Item	Symbol	Condition	Rating	Unit
Drain-Source Voltage	V_{DS}		15	V
Gate-Source Voltage	V_{GS}		-5	V
Total Power Dissipation	P_T	$T_C = 25^\circ\text{C}$	31.2	W
Storage Temperature	T_{stg}		-65 to +175	$^\circ\text{C}$
Channel Temperature	T_{ch}		175	$^\circ\text{C}$

Fujitsu recommends the following conditions for the reliable operation of GaAs FETs:

1. The drain-source operating voltage (V_{DS}) should not exceed 10 volts.
2. The forward and reverse gate currents should not exceed 16.0 and -2.8 mA respectively with gate resistance of 100 Ω .

ELECTRICAL CHARACTERISTICS (Ambient Temperature $T_a=25^\circ\text{C}$)

Item	Symbol	Test Conditions	Limit			Unit
			Min.	Typ.	Max.	
Saturated Drain Current	I_{DSS}	$V_{DS} = 5\text{V}, V_{GS} = 0\text{V}$	-	2500	3750	mA
Transconductance	g_m	$V_{DS} = 5\text{V}, I_{DS} = 1625\text{mA}$	-	2500	-	mS
Pinch-off Voltage	V_p	$V_{DS} = 5\text{V}, I_{DS} = 125\text{mA}$	-0.5	-1.5	-3.0	V
Gate Source Breakdown Voltage	V_{GSO}	$I_{GS} = -125\mu\text{A}$	-5.0	-	-	V
Output Power at 1dB G.C.P.	P_{1dB}	$V_{DS} = 10\text{V},$ $I_{DS} = 0.65I_{DSS}$ (Typ.), $f = 5.9 \sim 6.4 \text{GHz},$ $Z_S = Z_L = 50 \text{ohm}$	37.5	38.5	-	dBm
Power Gain at 1dB G.C.P.	G_{1dB}		9.0	10.0	-	dB
Drain Current	I_{dsr}		-	1625	1900	mA
Power-added Efficiency	η_{add}		-	37	-	%
Gain Flatness	ΔG		-	-	± 0.6	dB
3rd Order Intermodulation Distortion	IM_3	$f = 6.4 \text{GHz}, \Delta f = 10 \text{MHz}$ 2-Tone Test $P_{out} = 27.5\text{dBm S.C.L.}$	-44	-46	-	dBc
Thermal Resistance	R_{th}	Channel to Case	-	4.0	4.8	$^\circ\text{C}/\text{W}$
Channel Temperature Rise	ΔT_{ch}	$10\text{V} \times I_{dsr} \times R_{th}$	-	-	80	$^\circ\text{C}$

CASE STYLE: IB

G.C.P.: Gain Compression Point, S.C.L.: Single Carrier Level

FLM5964-6F

C-Band Internally Matched FET

POWER DERATING CURVE

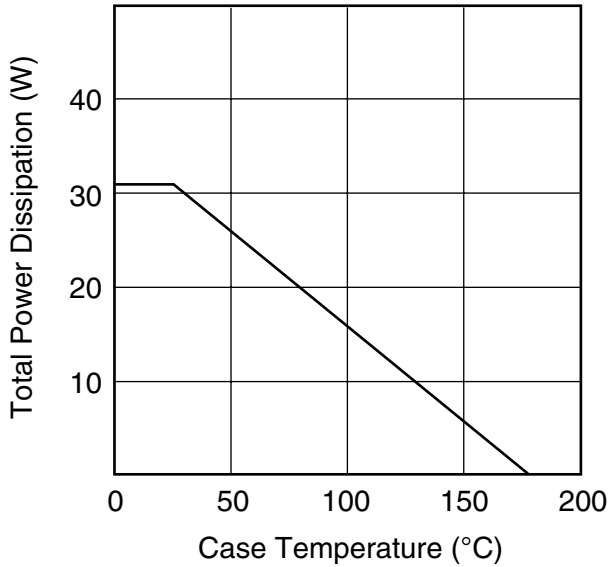

OUTPUT POWER & IM₃ vs. INPUT POWER

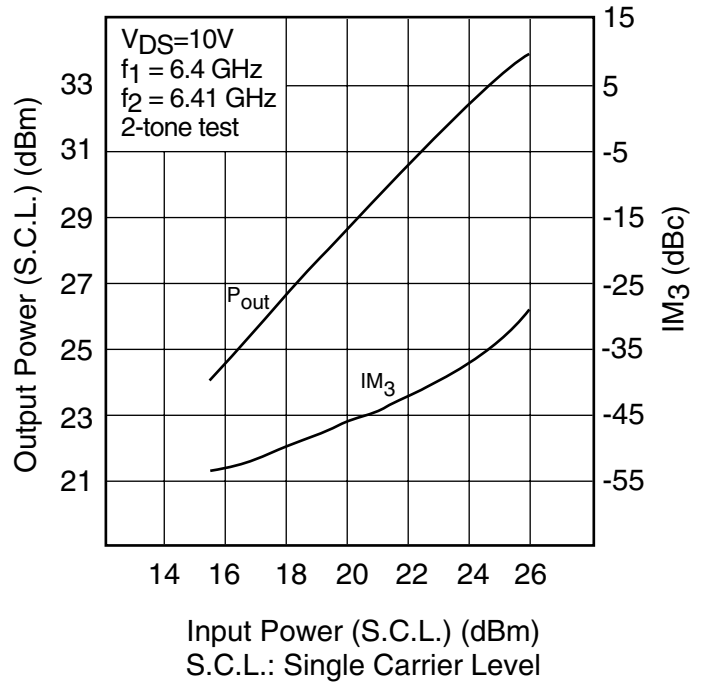

OUTPUT POWER vs. FREQUENCY

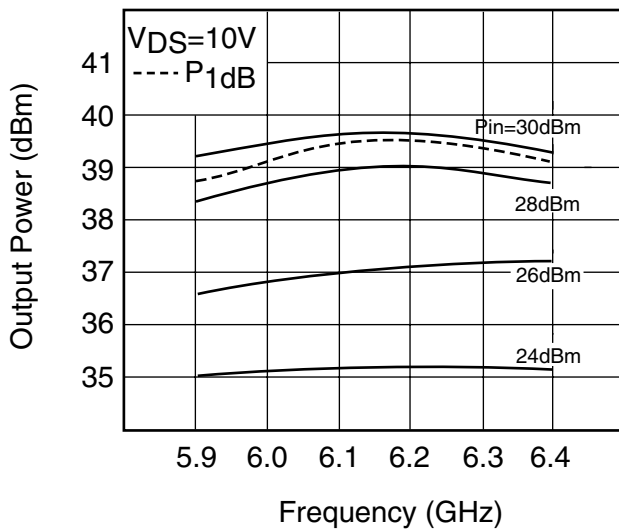

OUTPUT POWER vs. INPUT POWER

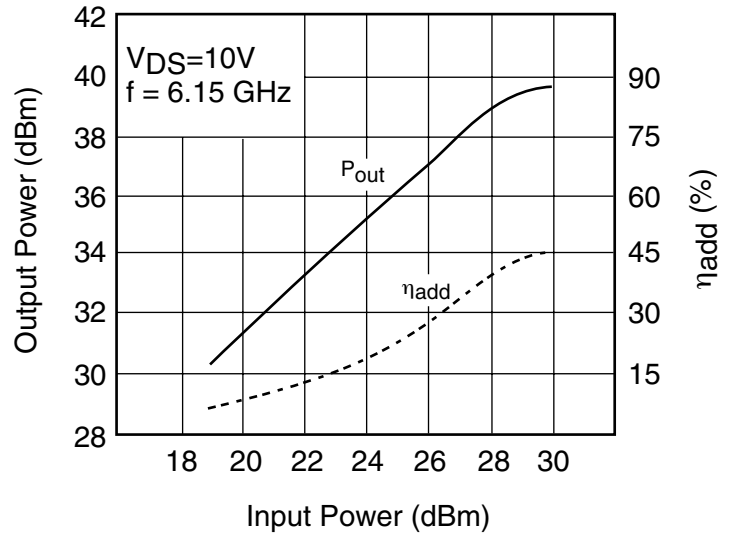

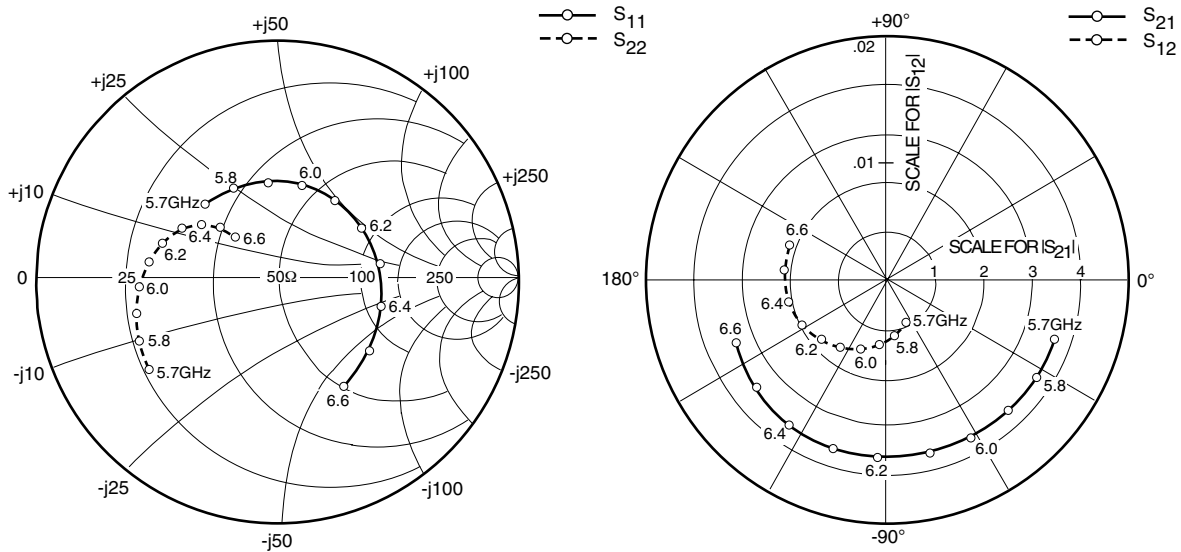

S-PARAMETERS

$V_{DS} = 10V, I_{DS} = 1625mA$

FREQUENCY (MHZ)	S11		S21		S12		S22	
	MAG	ANG	MAG	ANG	MAG	ANG	MAG	ANG
5700	.432	134.8	3.652	-19.7	.037	-65.3	.660	-145.4
5800	.417	116.5	3.676	-33.5	.045	-83.1	.641	-156.0
5900	.403	97.1	3.681	-47.6	.053	-98.2	.617	-166.4
6000	.395	75.9	3.705	-62.1	.061	-112.7	.589	-176.7
6100	.391	53.8	3.708	-77.0	.068	-126.4	.555	173.0
6200	.398	30.4	3.696	-92.2	.074	-140.2	.512	163.0
6300	.416	7.1	3.661	-107.9	.079	-154.4	.458	153.7
6400	.446	-16.1	3.609	-123.9	.083	-169.3	.396	145.0
6500	.484	-38.9	3.525	-140.6	.085	175.5	.325	138.7
6600	.529	-60.1	3.399	-157.1	.086	160.2	.253	137.3

FLM5964-6F

C-Band Internally Matched FET

Case Style "IB" Metal-Ceramic Hermetic Package

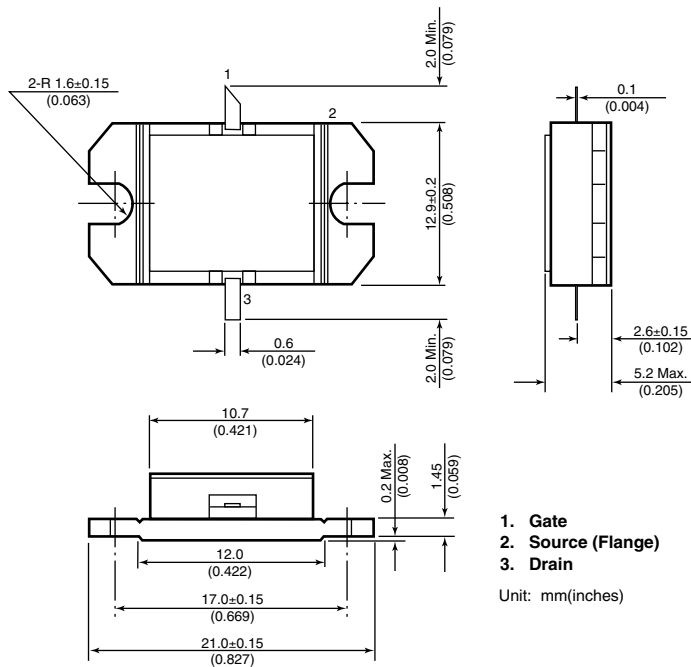

For further information please contact:

FUJITSU COMPOUND SEMICONDUCTOR, INC.

2355 Zanker Rd.
San Jose, CA 95131-1138, U.S.A.
Phone: (408) 232-9500
FAX: (408) 428-9111
www.fcsi.fujitsu.com

FUJITSU MICROELECTRONICS, LTD.

Compound Semiconductor Division
Network House
Norreys Drive
Maidenhead, Berkshire SL6 4FJ
Phone: +44 (0)1628 504800
FAX: +44 (0)1628 504888

CAUTION

Fujitsu Compound Semiconductor Products contain **gallium arsenide (GaAs)** which can be hazardous to the human body and the environment. For safety, observe the following procedures:

- Do not put these products into the mouth.
- Do not alter the form of this product into a gas, powder, or liquid through burning, crushing, or chemical processing as these by-products are dangerous to the human body if inhaled, ingested, or swallowed.
- Observe government laws and company regulations when discarding this product. This product must be discarded in accordance with methods specified by applicable hazardous waste procedures.

Fujitsu Limited reserves the right to change products and specifications without notice. The information does not convey any license under rights of Fujitsu Limited or others.

© 1998 FUJITSU COMPOUND SEMICONDUCTOR, INC.
Printed in U.S.A. FCSI0598M200

FUJITSU