

VRAM

256K x 4 DRAM WITH 512 x 4 SAM

FEATURES

- Industry standard pinout, timing and functions
- High-performance, CMOS silicon-gate process
- Single +5V ±10% power supply
- Inputs and outputs are fully TTL compatible
- Refresh modes: $\overline{\text{RAS}}$ -ONLY, $\overline{\text{CAS}}$ -BEFORE- $\overline{\text{RAS}}$ (CBR) and HIDDEN
- 512-cycle refresh within 8ms, with 32ms option
- Optional FAST PAGE MODE access cycles
- Dual port organization: 256K x 4 DRAM port 512 x 4 SAM port
- No refresh required for serial access memory
- Low power: 15mW standby; 275mW active, typical
- Fast access times – 70ns random, 22ns serial

SPECIAL FUNCTIONS

- JEDEC Standard Function set
- PERSISTENT MASKED WRITE
- SPLIT READ TRANSFER
- WRITE TRANSFER/SERIAL INPUT
- ALTERNATE WRITE TRANSFER
- BLOCK WRITE

OPTIONS

- Timing [DRAM, SAM (cycle/access)]
 - 70ns, 25ns/22ns - 7
 - 80ns, 30ns/25ns - 8
 - 100ns, 30ns/27ns -10
- Packages
 - Plastic SOJ (400 mil) DJ
 - Plastic ZIP (375 mil) Z
- Low power/extended refresh (32ms) L

MARKING

GENERAL DESCRIPTION

The MT42C4256 is a high-speed, dual port CMOS dynamic random access memory or video RAM (VRAM) containing 1,048,576 bits. These bits may be accessed by a 4-bit wide DRAM port or by a 512 x 4-bit serial access memory (SAM) port. Data may be transferred bidirectionally between the DRAM and the SAM. An extended refresh (32ms), low power standby option is available as the MT42C4256 L.

The DRAM portion of the VRAM is functionally identical to the MT4C4256 (256K x 4 DRAM). Four 512-bit data registers make up the SAM portion of the VRAM. Data I/O and internal data transfer are accomplished using three separate bidirectional data paths; the 4-bit random access

PIN ASSIGNMENT (Top View)

28-Pin SOJ (Q-4)

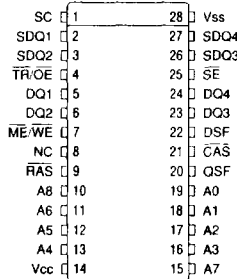

28-Pin ZIP (O-3)

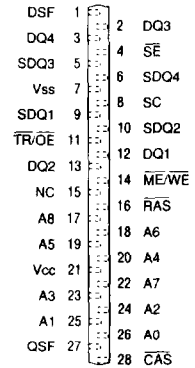

MULTIPORT DRAM

I/O port, the four internal 512 bit wide paths between the DRAM and the SAM, and the 4-bit serial I/O port for the SAM. The rest of the circuitry consists of the control, timing and address decoding logic.

Each port may be operated asynchronously and independently of the other except when data is being transferred internally. As with all DRAMs, the VRAM must be refreshed to maintain data. Refresh cycles must be timed so that all 512 combinations of $\overline{\text{RAS}}$ addresses are executed at least every 8ms, or 32ms for the MT42C4256 L, (regardless of sequence). Micron recommends evenly spaced refresh cycles for maximum data integrity. An internal transfer between the DRAM and the SAM counts as a refresh cycle. The SAM portion of the VRAM is fully static and does not require any refresh.

The operation and control of the MT42C4256 are optimized for high performance graphics and communication designs. The dual port architecture is well suited to buffering the sequential data used in raster graphics display, serial and parallel networking and data communications. Special features, such as SPLIT READ TRANSFER and BLOCK WRITE allow further enhancements to system performance.

FUNCTIONAL BLOCK DIAGRAM

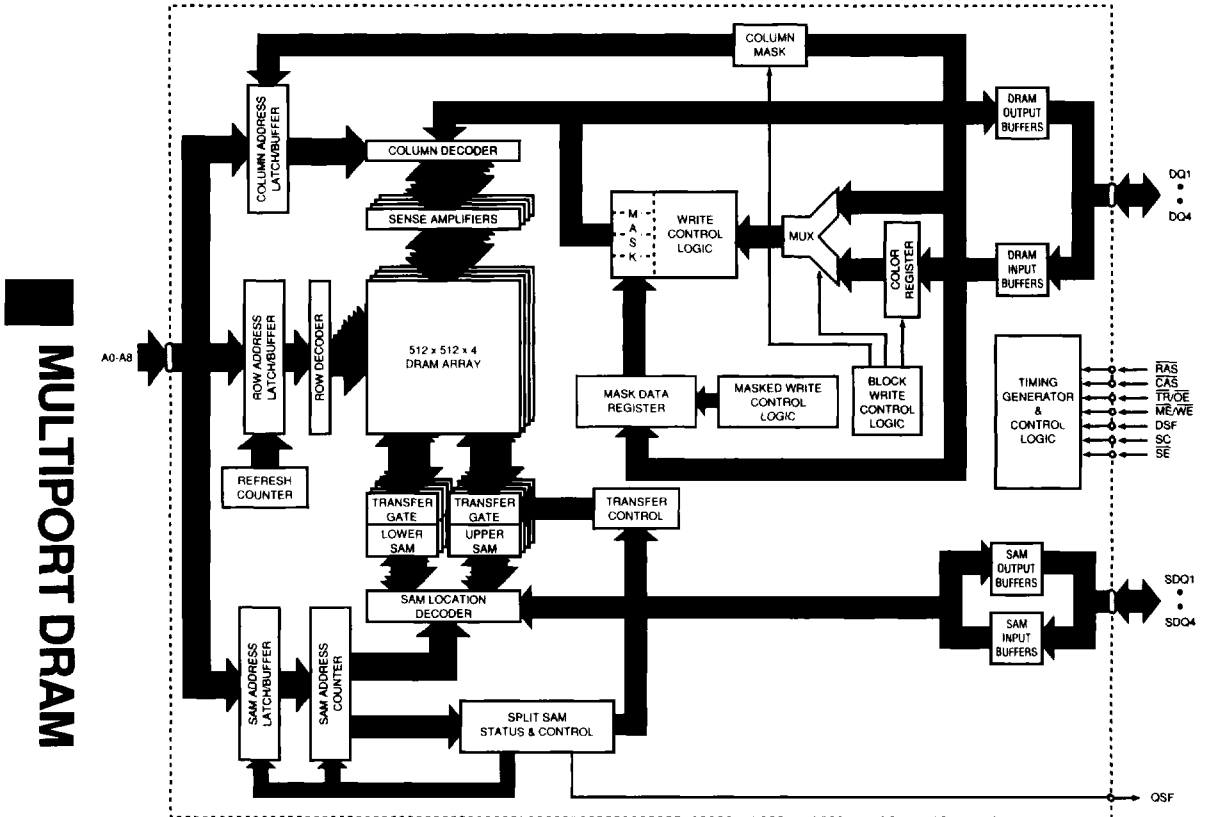

PIN DESCRIPTIONS

SOJ PIN NUMBERS	ZIP PIN NUMBERS	SYMBOL	TYPE	DESCRIPTION
1	8	SC	Input	Serial Clock: Clock input to the serial address counter for the SAM registers.
4	11	TR/ÖE	Input	Transfer Enable: Enables an internal TRANSFER operation at RAS (H → L), or Output Enable: Enables the DRAM output buffers when taken LOW after RAS goes LOW (CAS must also be LOW), otherwise the output buffers are in a High-Z state.
7	14	ME/WE	Input	Mask Enable: If ME/WE is LOW at the falling edge of RAS a MASKED WRITE cycle is performed, or Write Enable: ME/WE is also used to select a READ (ME/WE = H) or WRITE (ME/WE = L) cycle when accessing the DRAM. This includes a READ TRANSFER (ME/WE = H) or WRITE TRANSFER (ME/WE = L).
25	4	SE	Input	Serial Port Enable: SE enables the serial I/O buffers and allows a serial READ or WRITE operation to occur, otherwise the output buffers are in a High-Z state. SE is also used during a WRITE TRANSFER operation to indicate whether a WRITE TRANSFER or a SERIAL INPUT MODE ENABLE cycle is performed.
22	1	DSF	Input	Special Function Select: DSF is used to indicate which special functions (BLOCK WRITE, MASKED WRITE vs. PERSISTENT MASKED WRITE, etc.) are used on a particular access cycle.
9	16	RAS	Input	Row Address Strobe: RAS is used to clock-in the 9 row-address bits and strobe the ME/WE, TR/ÖE, DSF, SE, CAS and DQ inputs. It also acts as the master chip enable and must fall for initiation of any DRAM or TRANSFER cycle.
21	28	CAS	Input	Column Address Strobe: CAS is used to clock-in the 9 column-address bits, enable the DRAM output buffers (along with TR/ÖE), and strobe the DSF input.
19, 18, 17, 16, 13, 12, 11, 15, 10	26, 25, 24, 23, 20, 19, 18, 22, 17	A0-A8	Input	Address Inputs: For the DRAM operation, these inputs are multiplexed and clocked by RAS and CAS to select one 4-bit word out of the 256K available. During TRANSFER operations, A0 to A8 indicate the DRAM row being accessed (when RAS goes LOW) and the SAM start address (when CAS goes LOW).
5, 6, 23, 24	12, 13, 2, 3	DQ1-DQ4	Input/ Output	DRAM Data I/O: Data input/output for DRAM cycles; inputs for Mask Data Register and Color Register load cycles, and DQ and Column Mask inputs for BLOCK WRITE.
2, 3, 26, 27	9, 10, 5, 6	SDQ1-SDQ4	Input/ Output	Serial Data I/O: Input, output, or High-Z.
20	27	QSF	Output	Split SAM Status: QSF indicates which half of the SAM is being accessed. LOW if address is 0-255, HIGH if address is 256-511.
8	15	NC	-	No Connect: This pin should be left either unconnected or tied to ground.
14	21	Vcc	Supply	Power Supply: +5V ±10%
28	7	Vss	Supply	Ground

MULTIPORT DRAM

FUNCTIONAL DESCRIPTION

The MT42C4256 may be divided into three functional blocks (see Figure 1): the DRAM, the transfer circuitry, and the SAM. All of the operations described below are shown in the AC Timing Diagrams section of this data sheet and summarized in the Truth Table.

Note: For dual-function pins, the function not being discussed will be surrounded by parentheses. For example, the $\overline{TR}/\overline{OE}$ pin will be shown as $\overline{TR}/(\overline{OE})$ in references to transfer operations.

DRAM OPERATION

DRAM REFRESH

Like any DRAM based memory, the MT42C4256 VRAM must be refreshed to retain data. All 512 row address combinations must be accessed within 8ms. The MT42C4256 supports \overline{CAS} -BEFORE- \overline{RAS} , \overline{RAS} -ONLY and HIDDEN types of refresh cycles.

For the \overline{CAS} -BEFORE- \overline{RAS} REFRESH cycle, the row addresses are generated and stored in an internal address counter. The user need not supply any address data, and simply must perform 512 \overline{CAS} -BEFORE- \overline{RAS} cycles within the 8ms time period.

The refresh address must be generated externally and applied to A0-A8 inputs for \overline{RAS} -ONLY refresh cycles. The DQ pins remain in a High-Z state for both the \overline{RAS} -ONLY and \overline{CAS} -BEFORE- \overline{RAS} refresh cycles.

HIDDEN REFRESH cycles are performed by toggling \overline{RAS} (and keeping \overline{CAS} LOW) after a READ or WRITE cycle. This performs \overline{CAS} -BEFORE- \overline{RAS} cycles but does not disturb the DQ lines.

Any DRAM READ, WRITE, or TRANSFER cycle also refreshes the DRAM row being accessed. The SAM portion of the MT42C4256 is fully static and does not require any refreshing.

DRAM READ AND WRITE CYCLES

The DRAM portion of the VRAM is nearly identical to standard 256K x 4 DRAMs. However, because several of the DRAM control pins are used for additional functions on this part, several conditions that were undefined or in "don't care" states for the DRAM are specified for the VRAM. These conditions are highlighted in the following discussion. In addition, the VRAM has several special functions that can be used when writing to the DRAM.

The 18 address bits that are used to select a 4-bit word from the 262,144 available are latched into the chip using the A0-A8, \overline{RAS} and \overline{CAS} inputs. First, the 9 row-address bits are set up on the address inputs and clocked into the part when \overline{RAS} transitions from HIGH-to-LOW. Next, the 9 column address bits are set up on the address inputs and clocked-in when \overline{CAS} goes from HIGH-to-LOW.

Note: \overline{RAS} also acts as a "master" chip enable for the VRAM. If \overline{RAS} is inactive, HIGH, all other DRAM control pins (\overline{CAS} , $\overline{TR}/\overline{OE}$, $\overline{ME}/\overline{WE}$, etc.) are "don't care" and may change state without effect. No DRAM or TRANSFER cycles will be initiated without \overline{RAS} falling.

For single port DRAMS, the \overline{OE} pin is a "don't care" when \overline{RAS} goes LOW. However, for the VRAM, when \overline{RAS} goes LOW, $\overline{TR}/(\overline{OE})$ selects between DRAM access or TRANSFER cycles. $\overline{TR}/(\overline{OE})$ must be HIGH at the \overline{RAS} HIGH-to-LOW transition for all DRAM operations (except \overline{CAS} -BEFORE- \overline{RAS}).

If $(\overline{ME})/\overline{WE}$ is HIGH when \overline{CAS} goes LOW, a DRAM READ operation is performed and the data from the memory cells selected will appear at the DQ1-DQ4 port. The $(\overline{TR})/\overline{OE}$ input must transition from HIGH-to-LOW some time after \overline{RAS} falls to enable the DRAM output port.

For single port normal DRAMs, \overline{WE} is a "don't care" when \overline{RAS} goes LOW. For the VRAM, $\overline{ME}/(\overline{WE})$ is used, when \overline{RAS} goes LOW, to select between a MASKED WRITE cycle and a normal WRITE cycle. If $\overline{ME}/(\overline{WE})$ is LOW at the \overline{RAS} HIGH-to-LOW transition, a MASKED WRITE operation is selected. For any DRAM access cycle (READ or WRITE), $\overline{ME}/(\overline{WE})$ must be HIGH at the \overline{RAS} HIGH-to-LOW transition. If $(\overline{ME})/\overline{WE}$ is LOW before \overline{CAS} goes LOW, a DRAM EARLY-WRITE operation is performed and the data present on the DQ1-DQ4 data port will be written into the selected memory cells. If $(\overline{ME})/\overline{WE}$ goes LOW after \overline{CAS} goes LOW, a DRAM LATE-WRITE operation is performed. Refer to the AC timing diagrams.

The VRAM can perform all the normal DRAM cycles including READ, EARLY-WRITE, LATE-WRITE, READ-MODIFY-WRITE, FAST-PAGE-MODE READ, FAST-PAGE-MODE WRITE (Late or Early), and FAST-PAGE-MODE READ-MODIFY-WRITE. Refer to the AC timing parameters and diagrams in the data sheet for more details on these operations.

PERSISTENT MASKED WRITE

The PERSISTENT MASKED WRITE feature eliminates the need to rewrite the mask data before each MASKED WRITE cycle if the same mask data is being used repeatedly. To initiate a PERSISTENT MASKED WRITE, a LOAD MASK REGISTER cycle is performed by taking $\overline{ME}/(\overline{WE})$ and DSF HIGH when \overline{RAS} goes LOW. The mask data is loaded into the internal register when \overline{CAS} goes LOW.

PERSISTENT MASKED WRITE cycles may then be performed by taking $\overline{ME}/(\overline{WE})$ LOW and DSF HIGH when \overline{RAS} goes LOW. The contents of the mask data register will then be used as the mask data for the DRAM inputs. Unlike the NONPERSISTENT MASKED WRITE cycle, the data present on the DQ inputs is not loaded into the mask

register when \overline{RAS} falls, and the mask data register will not be cleared at the end of the cycle. Any number of PERSISTENT MASKED WRITE cycles, to any address, may be performed without having to reload the mask data register. Figure 2 shows the LOAD MASK REGISTER and two PERSISTENT MASKED WRITE cycles in operation. The LOAD MASK REGISTER and PERSISTENT MASKED WRITE cycles allow controllers that cannot provide mask data to the DQ pins at \overline{RAS} time to perform MASKED WRITE operations. PERSISTENT MASKED WRITE operations may be performed during FAST PAGE MODE cycles and the same mask will apply to all addressed columns in the addressed row.

MULTIPORT DRAM

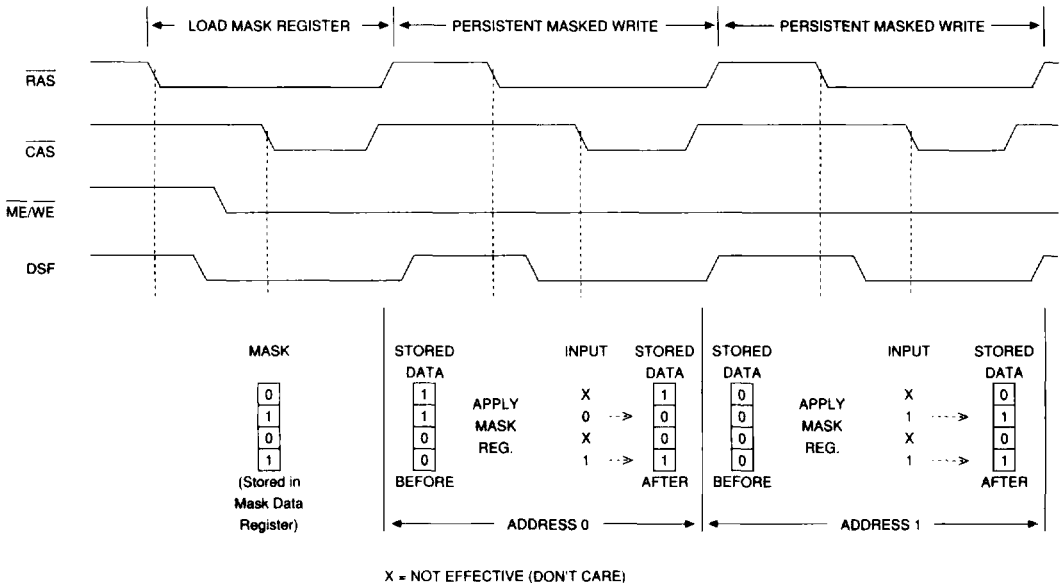

Figure 2
PERSISTENT MASKED WRITE EXAMPLE

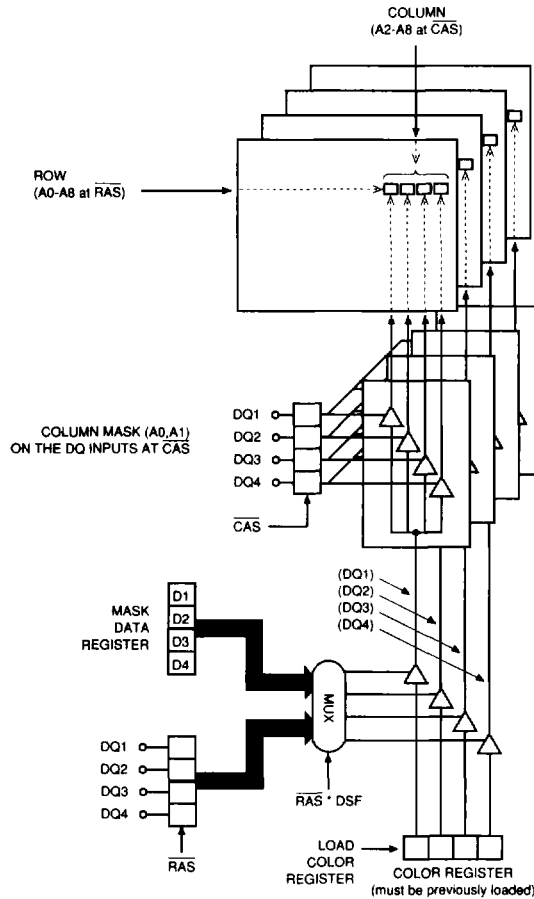

Figure 3
BLOCK WRITE EXAMPLE

BLOCK WRITE

If DSF is HIGH when $\overline{\text{CAS}}$ goes LOW, the MT42C4256 will perform a BLOCK WRITE cycle instead of a normal WRITE cycle. In BLOCK WRITE cycles, the contents of the color register are directly written to four adjacent column locations (see Figure 3). The color register must be loaded prior to beginning BLOCK WRITE cycles (see LOAD COLOR REGISTER). Each DQ location of the color register is written to the four column locations (or any of the four that are enabled) in the corresponding DQ bit plane.

The row is addressed as in a normal DRAM WRITE cycle.

However, when $\overline{\text{CAS}}$ goes LOW only the A2-A8 inputs are used. A2-A8 specify the "block" of four adjacent column locations that will be accessed. The DQ inputs are then used to determine what combination of the four column locations will be changed. DQ1 acts as a write enable for column location A0 = 0, A1 = 0; DQ2 controls column location A0 = 1, A1 = 0; DQ3 controls A0 = 0, A1 = 1; and DQ4 controls A0 = 1, A1 = 1. The write enable controls are active HIGH; the WRITE function is enabled by a logic 1 and disabled by a logic 0.

MULTI-PORT DRAM

NONPERSISTENT MASKED BLOCK WRITE

The MASKED WRITE functions can also be used during BLOCK WRITE cycles. NONPERSISTENT MASKED BLOCK WRITE operates exactly like the normal NONPERSISTENT MASKED WRITE, except that the mask is now applied to four column locations instead of just one.

Like NONPERSISTENT MASKED WRITE, the combination of $\overline{ME}/(\overline{WE})$ LOW and DSF LOW when \overline{RAS} goes LOW initiates a NONPERSISTENT MASKED cycle. The DSF pin must be driven HIGH when \overline{CAS} goes LOW, to perform the NONPERSISTENT MASKED BLOCK WRITE. By using both the column mask input and the MASKED WRITE function, any combination of the four bit planes or column locations may be masked.

PERSISTENT MASKED BLOCK WRITE

This cycle is also performed exactly like the normal PERSISTENT MASKED WRITE except that DSF is HIGH when \overline{CAS} goes LOW to indicate the BLOCK WRITE function. Both the mask data register and the color register must be loaded with the appropriate data prior to starting a PERSISTENT MASKED BLOCK WRITE.

LOAD MASK DATA REGISTER

The LOAD MASK REGISTER operation and timing are identical to a normal WRITE cycle except that DSF is HIGH when \overline{RAS} goes LOW. As shown in the Truth Table, the combination of $\overline{TR}/(\overline{OE})$, $\overline{ME}/(\overline{WE})$, and DSF being HIGH when \overline{RAS} goes LOW indicates the cycle is a LOAD REGIS-

TER cycle. DSF is used when \overline{CAS} goes LOW to select the register to be loaded and must be LOW for a LOAD MASK REGISTER cycle. The data present on the DQ lines will then be written to the mask data register.

Note: *For a normal DRAM WRITE cycle, the mask data register is disabled but not modified. The contents of mask data register will not be changed unless a NONPERSISTENT MASKED WRITE cycle or a LOAD MASK REGISTER cycle is performed.*

The row address supplied will be refreshed, but it is not necessary to provide any particular row address. The column address inputs are ignored during a LOAD MASK REGISTER cycle.

The mask data register contents are used during PERSISTENT MASKED WRITE and PERSISTENT MASKED BLOCK WRITE cycles to selectively enable writes to the four DQ planes.

LOAD COLOR REGISTER

A LOAD COLOR REGISTER cycle is identical to the LOAD MASK REGISTER cycle except DSF is HIGH when \overline{CAS} goes LOW. The contents of the color register are retained until changed by another LOAD COLOR REGISTER cycle (or the part loses power) and are used as data inputs during BLOCK WRITE cycles.

TRANSFER OPERATIONS

TRANSFER operations are initiated when $\overline{TR}/(\overline{OE})$ is LOW then \overline{RAS} goes LOW. The state of $(\overline{ME})/\overline{WE}$ when \overline{RAS} goes LOW indicates the direction of the TRANSFER (to or from the DRAM), and DSF is used to select between NORMAL TRANSFER, SPLIT READ TRANSFER, and ALTERNATE WRITE TRANSFER cycles. Each of the TRANSFER cycles available is described below.

READ TRANSFER (DRAM-TO-SAM TRANSFER)

If $(\overline{ME})/\overline{WE}$ is HIGH and DSF is LOW when \overline{RAS} goes LOW, a READ TRANSFER cycle is selected. The row address bits indicate the four 512-bit DRAM row planes that are to be transferred to the four SAM data register planes. The column address bits indicate the start address (or Tap address) of the serial output cycle from the SAM data registers. \overline{CAS} must fall for every TRANSFER in order to load a valid Tap address. A read transfer may be accomplished in two ways. If the transfer is to be synchronized

with SC (REAL-TIME READ TRANSFER), $\overline{TR}/(\overline{OE})$ is taken HIGH after \overline{CAS} goes LOW. If the transfer does not have to be synchronized with SC (READ TRANSFER), $\overline{TR}/(\overline{OE})$ may go HIGH before \overline{CAS} goes LOW (refer to the AC Timing Diagrams). The 2,048 bits of DRAM data are written into the SAM data registers and the serial shift start address is stored in an internal 9-bit register. QSF will be LOW if access is from the lower half (addresses 0 through 255), and HIGH if access is from the upper half (256 through 511). If \overline{SE} is LOW, the first bits of the new row data will appear at the serial outputs with the first SC clock pulse. \overline{SE} enables the serial outputs and may be either HIGH or LOW during this operation. The SAM address pointer will increment with the SC LOW-to-HIGH transition, regardless of the state of \overline{SE} . Performing a READ TRANSFER cycle sets the direction of the SAM I/O buffers to the output mode.

MULTIPOINT DRAM

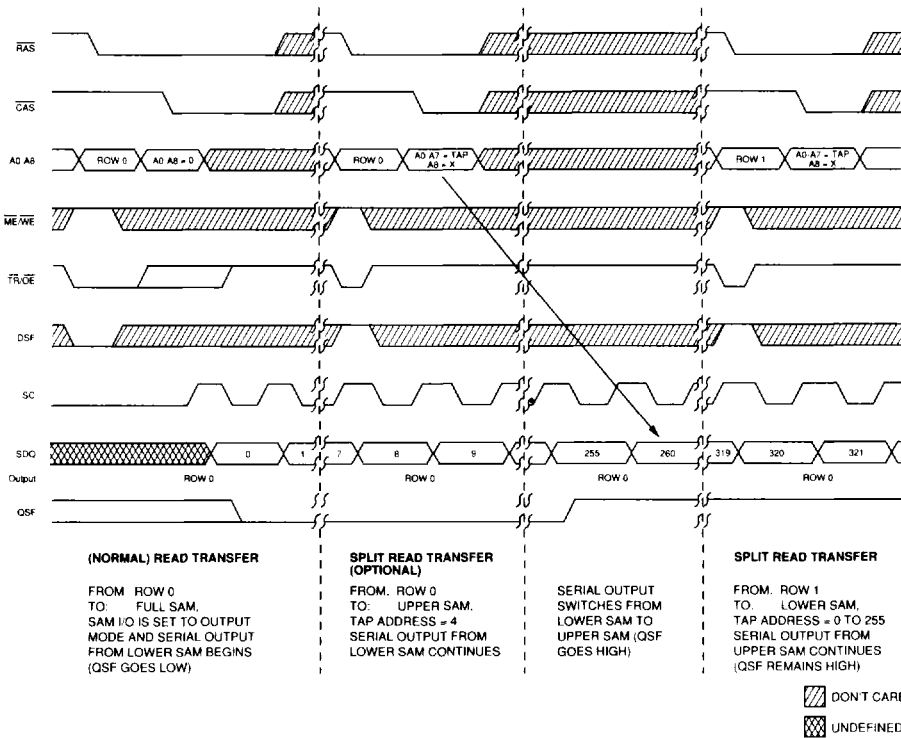

Figure 4
TYPICAL SPLIT-READ-TRANSFER INITIATION SEQUENCE

SPLIT READ TRANSFER (SPLIT DRAM-TO-SAM TRANSFER)

The SPLIT READ TRANSFER (SRT) cycle eliminates the critical transfer timing required to maintain a continuous serial output data stream. When using normal TRANSFER cycles, the REAL-TIME READ TRANSFER cycle has to occur immediately after the last bit of "old data" was clocked out of the SAM port.

When using the SPLIT TRANSFER mode, the SAM is divided into an upper half and a lower half. While data is being serially read from one half of the SAM, new DRAM data may be transferred to the other half. The transfer may occur at any time while the other half is sending data and need not be synchronized with the SC clock.

The TR/(OE) timing is also relaxed for SPLIT TRANSFER cycles. The rising edge of TR/(OE) is not used to complete the TRANSFER cycle and therefore is independent of the rising edges of RAS or CAS. The transfer timing is generated internally for SPLIT TRANSFER cycles. A SPLIT READ TRANSFER does not change the direction of the SAM port.

A normal, non-split READ TRANSFER cycle must precede any sequence of SPLIT READ TRANSFER cycles to set SAM I/O direction and provide a reference to which half of the SAM the access will begin. Then SPLIT READ TRANSFERS may be initiated by taking DSF HIGH when RAS goes LOW during the TRANSFER cycle. As in nonsplit transfers, the row address is used to specify the DRAM row to be transferred. The column address, A0-A7, is used to input the SAM Tap address. Address pin A8 is a "don't care" when the Tap address is loaded at the HIGH-to-LOW transition of CAS. It is internally generated so that the SPLIT TRANSFER will be to the SAM half not currently being accessed.

Figure 4 shows a typical SPLIT READ TRANSFER initiation sequence. The normal READ TRANSFER is first performed, followed by a SPLIT READ TRANSFER of the same row to the upper half of the SAM. The SRT to the upper half is optional and need only be done if the Tap for the upper half is $\neq 0$. Serial access continues, and when the SAM address counter reaches 255 ("A8" = 0, A0-A7 = 1), the new Tap address is loaded for the next half ("A8" = 1, A0-A7 = Tap) and the QSF output goes HIGH. Once the serial access has switched to the upper SAM, new data may be transferred to the lower SAM. The controller must wait for the state of QSF to change and then the new data may be transferred to the SAM half not being accessed. For example, the next step in Figure 4 would be to wait until QSF went LOW (indicating that row-1 data is shifting out of the lower SAM) and then transfer the upper half of row 1 to the upper SAM. If the half boundary is reached before an SRT is done for the next half a Tap address of "0" will be used. Access will start at 0 if going to the lower half, or 256 if going to the upper half. See Figure 5.

WRITE TRANSFER (SAM-TO-DRAM TRANSFER)

The operation of the WRITE TRANSFER is identical to the READ TRANSFER described previously except (ME)/WE and SE must be LOW when RAS goes LOW. The row address indicates the DRAM row to which the SAM data registers will be written. The column address (Tap) indicates the starting address of the next SERIAL INPUT cycle for the SAM data registers. A WRITE TRANSFER changes the direction of the SAM I/O buffers to the input mode. QFS is LOW if access is to the lower half of the SAM, and HIGH if access is to the upper half.

MULTI-PORT DRAM

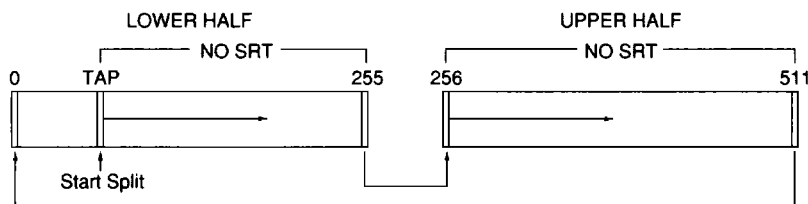

**Figure 5
SPLIT SAM TRANSFER**

PSEUDO WRITE TRANSFER (SERIAL-INPUT-MODE ENABLE)

The PSEUDO WRITE TRANSFER cycle is used to change the direction of SAM port from output to input without performing a WRITE TRANSFER cycle. A PSEUDO WRITE TRANSFER cycle is a WRITE TRANSFER cycle with \overline{SE} held HIGH instead of LOW. The DRAM data will not be disturbed and the SAM will be ready to accept input data.

ALTERNATE WRITE TRANSFER (SAM-TO-DRAM TRANSFER)

The operation of the ALTERNATE WRITE TRANSFER is identical to the WRITE TRANSFER except that the DSF pin is HIGH and $(\overline{ME})/\overline{WE}$ is LOW when \overline{RAS} goes LOW, allowing \overline{SE} to be a "don't care." This allows the outputs to be disabled using \overline{SE} during a WRITE TRANSFER cycle. ALTERNATE WRITE TRANSFER will change the SAM I/O direction to an input condition.

SERIAL INPUT AND SERIAL OUTPUT

The control inputs for SERIAL INPUT and SERIAL OUTPUT are SC and \overline{SE} . The rising edge of SC increments the serial address counter and provides access to the next SAM location. \overline{SE} enables or disables the serial input/output buffers.

Serial output of the SAM contents will start at the serial start address that was loaded in the SAM address counter during a READ or SPLIT READ TRANSFER cycle. The SC input increments the address counter and presents the contents of the next SAM location to the 4-bit port. \overline{SE} is used as an output enable during the SAM output operation. The serial address is automatically incremented with every SC LOW-to-HIGH transition, regardless of whether \overline{SE} is HIGH or LOW. The address progresses through the SAM

and will wrap around (after count 255 or 511) to the Tap address of the next half for split modes. If an SRT was not performed before the half boundary is reached the count will progress as illustrated in Figure 5. Address count will wrap around (after count 511) to Tap address 0 if in the "full" SAM modes.

SC is also used to clock-in data when the device is in the serial input mode. As in the serial output operation, the contents of the SAM address counter (loaded when the serial input mode was enabled) will determine the serial address of the first 4-bit word written. \overline{SE} acts as a write enable for serial input data and must be LOW for valid serial input. If $\overline{SE} = \text{HIGH}$, the data inputs are disabled and the SAM contents will not be modified. The serial address counter is incremented with every LOW-to-HIGH transition of SC, regardless of the logic level on the \overline{SE} input.

POWER-UP AND INITIALIZATION

After V_{CC} is at specified operating conditions, for 100 μ s minimum, eight \overline{RAS} cycles must be executed to initialize the dynamic memory array. Micron recommends that $\overline{RAS} = (\overline{TR})/\overline{OE} \geq V_{IH}$ during power up to ensure that the DRAM I/O pins (DQs) are in a High-Z state. The DRAM array will contain random data.

The SAM portion of the MT42C4256 is completely static in operation and does not require refresh or initialization. The SAM port will power-up in the serial input mode (WRITE TRANSFER) and the I/O pins (SDQs) will be High-Z, regardless of the state of \overline{SE} . The mask and color register will contain random data after power-up. QSF initializes in the LOW state.

TRUTH TABLE

CODE	FUNCTION	RAS FALLING EDGE					CAS FALL	A0-A8 ¹		DQ1-DQ4 ²		REGISTERS		
		CAS	TR/OE	ME/WE	DSF	SE	DSF	RAS	CAS	RAS	CAS,WE ³	MASK	COLOR	
DRAM OPERATIONS														
CBR	CAS-BEFORE RAS REFRESH	0	X	X	X	X	X	—	X	—	X	X	X	X
ROR	RAS-ONLY REFRESH	1	1	X	X	X	—	ROW	—	X	—	X	X	
RW	NORMAL DRAM READ OR WRITE	1	1	1	0	X	0	ROW	COLUMN	X	VALID DATA	X	X	
RWNM	NONPERSISTENT (LOAD AND USE) MASKED WRITE TO DRAM	1	1	0	0	X	0	ROW	COLUMN	WRITE MASK	VALID DATA	LOAD & USE	X	
RWOM	PERSISTENT (USE REGISTER) MASKED WRITE TO DRAM	1	1	0	1	X	0	ROW	COLUMN	X	VALID DATA	USE	X	
BW	BLOCK WRITE TO DRAM (NO DATA MASK)	1	1	1	0	X	1	ROW	COLUMN (A2-AB)	X	COLUMN MASK	X	USE	
BWNM	NONPERSISTENT (LOAD & USE) MASKED BLOCK WRITE TO DRAM	1	1	0	0	X	1	ROW	COLUMN	WRITE MASK	COLUMN MASK	LOAD & USE	USE	
BWOM	PERSISTENT (USE MASK REGISTER) MASKED BLOCK WRITE TO DRAM	1	1	0	1	X	1	ROW	COLUMN (A2-AB)	X	COLUMN MASK	USE	USE	
REGISTER OPERATIONS														
LMR	LOAD MASK REGISTER	1	1	1	1	X	0	ROW ⁴	X	X	WRITE MASK	LOAD	X	
LCR	LOAD COLOR REGISTER	1	1	1	1	X	1	ROW ⁴	X	X	COLOR DATA	X	LOAD	
TRANSFER OPERATIONS														
RT	READ TRANSFER (DRAM-TO-SAM TRANSFER)	1	0	1	0	X	X	ROW	TAP ⁵	X	X	X	X	
SRT	SPLIT READ TRANSFER (SPLIT DRAM-TO-SAM TRANSFER)	1	0	1	1	X	X	ROW	TAP ⁵	X	X	X	X	
WT	WRITE TRANSFER (SAM-TO-DRAM TRANSFER)	1	0	0	0	0	X	ROW	TAP ⁵	X	X	X	X	
PWT	PSEUDO WRITE TRANSFER (SERIAL-INPUT-MODE ENABLE)	1	0	0	0	1	X	ROW ⁴	TAP ⁵	X	X	X	X	
AWT	ALTERNATE WRITE TRANSFER (SAM-TO-DRAM TRANSFER)	1	0	0	1	X	X	ROW	TAP ⁵	X	X	X	X	

- NOTE:**
1. These columns show what must be present on the A0-A8 inputs when $\overline{\text{RAS}}$ falls and when $\overline{\text{CAS}}$ falls.
 2. These columns show what must be present on the DQ1-DQ4 inputs when $\overline{\text{RAS}}$ falls and when $\overline{\text{CAS}}$ falls.
 3. On WRITE cycles (except BLOCK WRITE), the input data is latched at the falling edge of $\overline{\text{CAS}}$ or $\overline{\text{ME/WE}}$, whichever is later. Similarly, on READ cycles, the output data is activated at the falling edge of $\overline{\text{CAS}}$ or $\overline{\text{TR/OE}}$, whichever is later.
 4. The ROW that is addressed will be refreshed, but no particular ROW address is required.
 5. This is the SAM location that the first SC cycle will access. For split SAM transfers, the Tap will be the first address location accessed of the "new" SAM half after the boundary of the current half is reached (255 for lower half, 511 for upper half).

ABSOLUTE MAXIMUM RATINGS*

Voltage on Vcc Supply Relative to Vss -1V to +7V
 Operating Temperature, T_A (Ambient) 0°C to +70°C
 Storage Temperature (Plastic) -55°C to +150°C
 Power Dissipation 1W
 Short Circuit Output Current 50mA

*Stresses greater than those listed under "Absolute Maximum Ratings" may cause permanent damage to the device. This is a stress rating only and functional operation of the device at these or any other conditions above those indicated in the operational sections of this specification is not implied. Exposure to absolute maximum rating conditions for extended periods may affect reliability.

RECOMMENDED DC OPERATING CONDITIONS

(0°C ≤ T_A ≤ 70°C)

PARAMETER/CONDITION	SYMBOL	MIN	MAX	UNITS	NOTES
Supply Voltage	V _{CC}	4.5	5.5	V	1
Input High (Logic 1) Voltage, All Inputs	V _{IH}	2.4	V _{CC} +1	V	1
Input Low (Logic 0) Voltage, All Inputs	V _{IL}	-1.0	0.8	V	1

DC ELECTRICAL CHARACTERISTICS

(0°C ≤ T_A ≤ 70°C; V_{CC} = 5V ±10%)

PARAMETER/CONDITION	SYMBOL	MIN	MAX	UNITS	NOTES
INPUT LEAKAGE CURRENT Any input (0V ≤ V _{IN} ≤ V _{CC}); all other pins not under test = 0V	I _L	-10	10	μA	
OUTPUT LEAKAGE CURRENT (DQ, SDQ disabled, 0V ≤ V _{OUT} ≤ V _{CC})	I _{OZ}	-10	10	μA	
OUTPUT LEVELS Output High Voltage (I _{OUT} = -2.5mA)	V _{OH}	2.4		V	1
Output Low Voltage (I _{OUT} = 2.5mA)	V _{OL}		0.4	V	

CAPACITANCE

PARAMETER	SYMBOL	MIN	MAX	UNITS	NOTES
Input Capacitance: A0-A8	C _{I1}		5	pF	2
Input Capacitance: RAS, CAS, ME/WE, TR/OE, SC, SE, DSF	C _{I2}		7	pF	2
Input/Output Capacitance: DQ, SDQ	C _{I/O}		9	pF	2
Output Capacitance: QSF	C _O		9	pF	2

MULTI-PORT DRAM

CURRENT DRAIN, SAM IN STANDBY

(0°C ≤ T_A ≤ 70°C; V_{CC} = 5V ±10%)

PARAMETER/CONDITION	SYMBOL	MAX			UNITS	NOTES
		-7	-8	-10		
OPERATING CURRENT (\overline{RAS} and \overline{CAS} = Cycling; $t_{RC} = t_{RC}(\text{MIN})$)	I _{CC1}	95	85	75	mA	3, 4, 26
OPERATING CURRENT: FAST PAGE MODE ($\overline{RAS} = V_{IL}$; \overline{CAS} = Cycling; $t_{PC} = t_{PC}(\text{MIN})$)	I _{CC2}	85	75	65	mA	3, 4, 27
STANDBY CURRENT: TTL INPUT LEVELS Power supply standby current ($\overline{RAS} = \overline{CAS} = V_{IH}$ after 8 \overline{RAS} cycles (MIN), other inputs ≥ V _{IH} or ≤ V _{IL})	I _{CC3}	8	8	8	mA	4
STANDBY CURRENT: CMOS INPUT LEVELS (MT42C4256 L only) ($\overline{RAS} = \overline{CAS} \geq V_{CC} - 0.2V$, other inputs ≥ V _{CC} - 0.2V or ≤ -0.2V)	I _{CC4}	500	500	500	μA	4
REFRESH CURRENT: \overline{RAS} -ONLY (\overline{RAS} = Cycling; $\overline{CAS} = V_{IH}$)	I _{CC5}	95	85	75	mA	3, 26
REFRESH CURRENT: \overline{CAS} -BEFORE- \overline{RAS} (\overline{RAS} and \overline{CAS} = Cycling)	I _{CC6}	95	85	75	mA	3, 5
REFRESH CURRENT: BATTERY BACKUP (BBU) MT42C4256 L only Average power supply current during BATTERY BACKUP refresh: $\overline{CAS} \leq 0.2V$ or \overline{CAS} -BEFORE- \overline{RAS} cycling; $\overline{RAS} = t_{RAS}(\text{MIN})$ to 300ns; $\overline{ME}/\overline{WE}$, A0-A8 and DQs ≥ V _{CC} - 0.2V or ≤ 0.2V (DQs may be left open), $t_{RC} = 62.5\mu s$ (512 rows at 62.5μs = 32ms)	I _{CC7}	600	600	600	μA	3, 5
SAM/DRAM DATA TRANSFER	I _{CC8}	105	95	95	mA	3

MULTIPOINT DRAM

CURRENT DRAIN, SAM ACTIVE (t_{SC} = MIN)

(0°C ≤ T_A ≤ 70°C; V_{CC} = 5V ±10%)

PARAMETER/CONDITION	SYMBOL	MAX			UNITS	NOTES
		-7	-8	-10		
OPERATING CURRENT (\overline{RAS} and \overline{CAS} = Cycling; $t_{RC} = t_{RC}(\text{MIN})$)	I _{CC9}	150	130	120	mA	3, 4, 26
OPERATING CURRENT: FAST PAGE MODE ($\overline{RAS} = V_{IL}$; \overline{CAS} = Cycling; $t_{PC} = t_{PC}(\text{MIN})$)	I _{CC10}	140	120	110	mA	3, 4, 27
STANDBY CURRENT: TTL INPUT LEVELS Power supply standby current ($\overline{RAS} = \overline{CAS} = V_{IH}$ after 8 \overline{RAS} cycles (MIN), other inputs ≥ V _{IH} or ≤ V _{IL})	I _{CC11}	55	45	45	mA	3, 4
REFRESH CURRENT: \overline{RAS} -ONLY (\overline{RAS} = Cycling; $\overline{CAS} = V_{IH}$)	I _{CC12}	150	130	120	mA	3, 4, 26
REFRESH CURRENT: \overline{CAS} -BEFORE- \overline{RAS} (\overline{RAS} and \overline{CAS} = Cycling)	I _{CC13}	150	130	120	mA	3, 4, 5
SAM/DRAM DATA TRANSFER	I _{CC14}	160	130	125	mA	3, 4

DRAM TIMING PARAMETERS

ELECTRICAL CHARACTERISTICS AND RECOMMENDED AC OPERATING CONDITIONS

(Notes: 6, 7, 8, 9, 10, 11, 12, 13) (0°C ≤ T_A ≤ +70°C; V_{CC} = 5V ±10%)

AC CHARACTERISTICS PARAMETER	SYM	-7		-8		-10		UNITS	NOTES
		MIN	MAX	MIN	MAX	MIN	MAX		
Random READ or WRITE cycle time	¹ RC	130		150		180		ns	
READ-MODIFY-WRITE cycle time	¹ RWC	175		190		230		ns	
FAST-PAGE-MODE READ or WRITE cycle time	¹ PC	45		50		55		ns	
FAST-PAGE-MODE READ-MODIFY-WRITE cycle time	¹ PRWC	90		95		110		ns	
Access time from $\overline{\text{RAS}}$	¹ RAC		70		80		100	ns	14
Access time from $\overline{\text{CAS}}$	¹ CAC		20		25		25	ns	15
Access time from (TR)/ $\overline{\text{OE}}$	¹ OE		20		20		25	ns	
Access time from column address	¹ AA		35		40		45	ns	
Access time from $\overline{\text{CAS}}$ precharge	¹ CPA		40		45		50	ns	
$\overline{\text{RAS}}$ pulse width	¹ RAS	70	20,000	80	20,000	100	20,000	ns	
$\overline{\text{RAS}}$ pulse width (FAST PAGE MODE)	¹ RASP	70	100,000	80	100,000	100	100,000	ns	
$\overline{\text{RAS}}$ hold time	¹ RSH	20		25		25		ns	
$\overline{\text{RAS}}$ precharge time	¹ RP	50		60		70		ns	
$\overline{\text{CAS}}$ pulse width	¹ CAS	20	10,000	25	10,000	25	10,000	ns	
$\overline{\text{CAS}}$ hold time	¹ CSH	70		80		100		ns	
$\overline{\text{CAS}}$ precharge time	¹ CP	10		10		10		ns	
$\overline{\text{RAS}}$ to $\overline{\text{CAS}}$ delay time	¹ RCD	20	50	20	55	25	75	ns	17
$\overline{\text{CAS}}$ to $\overline{\text{RAS}}$ precharge time	¹ CRP	10		10		10		ns	
Row address setup time	¹ ASR	0		0		0		ns	
Row address hold time	¹ RAH	10		10		15		ns	
$\overline{\text{RAS}}$ to column address delay time	¹ RAD	15	35	15	40	20	50	ns	18
Column address setup time	¹ ASC	0		0		0		ns	
Column address hold time	¹ CAH	15		15		15		ns	
Column address hold time (referenced to $\overline{\text{RAS}}$)	¹ AR	45		55		70		ns	
Column address to $\overline{\text{RAS}}$ lead time	¹ RAL	35		40		50		ns	
Read command setup time	¹ RCS	0		0		0		ns	
Read command hold time (referenced to $\overline{\text{CAS}}$)	¹ RCH	0		0		0		ns	19
Read command hold time (referenced to RAS)	¹ RRH	0		0		0		ns	19
$\overline{\text{CAS}}$ to output in Low-Z	¹ CLZ	3		3		3		ns	
Output buffer turn-off delay	¹ OFF	3	20	3	20	3	20	ns	20, 23
Output disable	¹ OD	3	10	3	10	3	20	ns	20, 23
Output disable hold time from start of WRITE	¹ OEH	10		10		20		ns	25
$\overline{\text{OE}}$ LOW to $\overline{\text{RAS}}$ HIGH delay time	¹ ROH	0		0		0		ns	

MULTIPORT DRAM

DRAM TIMING PARAMETERS (continued) ELECTRICAL CHARACTERISTICS AND RECOMMENDED AC OPERATING CONDITIONS

(Notes: 6, 7, 8, 9, 10, 11, 12, 13) ($0^{\circ}\text{C} \leq T_A \leq +70^{\circ}\text{C}$; $V_{CC} = 5V \pm 10\%$)

AC CHARACTERISTICS PARAMETER	SYM	-7		-8		-10		UNITS	NOTES
		MIN	MAX	MIN	MAX	MIN	MAX		
Write command setup time	'WCS	0		0		0		ns	21
Write command hold time	'WCH	15		15		15		ns	
Write command hold time (referenced to $\overline{\text{RAS}}$)	'WCR	45		55		70		ns	
Write command pulse width	'WP	15		15		15		ns	
Write command to $\overline{\text{RAS}}$ lead time	'RWL	20		20		20		ns	
Write command to $\overline{\text{CAS}}$ lead time	'CWL	20		20		20		ns	
Data-in setup time	'DS	0		0		0		ns	22
Data-in hold time	'DH	15		15		15		ns	22
Data-in hold time (referenced to $\overline{\text{RAS}}$)	'DHR	45		55		65		ns	
$\overline{\text{RAS}}$ to $\overline{\text{WE}}$ delay time	'RWD	90		100		130		ns	21
Column address to $\overline{\text{WE}}$ delay time	'AWD	55		65		75		ns	21
$\overline{\text{CAS}}$ to $\overline{\text{WE}}$ delay time	'CWD	40		45		55		ns	21
Transition time (rise or fall)	'T	3	35	3	35	3	35	ns	9, 10
Refresh period (512 cycles)	'REF		8 (32)		8 (32)		8 (32)	ms	29
$\overline{\text{RAS}}$ to $\overline{\text{CAS}}$ precharge time	'RPC	0		0		0		ns	
$\overline{\text{CAS}}$ setup time ($\overline{\text{CAS-BEFORE-RAS}}$ REFRESH)	'CSR	10		10		10		ns	5
$\overline{\text{CAS}}$ hold time ($\overline{\text{CAS-BEFORE-RAS}}$ REFRESH)	'CHR	10		10		10		ns	5
$\overline{\text{ME/WE}}$ to $\overline{\text{RAS}}$ setup time	'WSR	0		0		0		ns	
$\overline{\text{ME/WE}}$ to $\overline{\text{RAS}}$ hold time	'RWH	15		15		15		ns	
Mask Data to $\overline{\text{RAS}}$ setup time	'MS	0		0		0		ns	
Mask Data to $\overline{\text{RAS}}$ hold time	'MH	15		15		15		ns	

MULTIPORT DRAM

TRANSFER AND MODE CONTROL TIMING PARAMETERS
ELECTRICAL CHARACTERISTICS AND RECOMMENDED AC OPERATING CONDITIONS
(Notes 6, 7, 8, 9, 10) (0° C ≤ T_A ≤ + 70°C; V_{CC} = 5V ±10%)

AC CHARACTERISTICS PARAMETER	SYM	-7		-8		-10		UNITS	NOTES
		MIN	MAX	MIN	MAX	MIN	MAX		
TR/(OE) LOW to RAS setup time	↑TLS	0		0		0		ns	
TR/(OE) LOW to RAS hold time	↑TLH	15	10,000	15	10,000	15	10,000	ns	
TR/(OE) LOW to RAS hold time (REAL-TIME READ TRANSFER only)	↑RTH	65	10,000	70	10,000	80	10,000	ns	
TR/(OE) LOW to CAS hold time (REAL-TIME READ TRANSFER only)	↑CTH	25		25		25		ns	
TR/(OE) HIGH to SC lead time	↑TSL	5		5		5		ns	
TR/(OE) HIGH to RAS precharge time	↑TRP	50		60		70		ns	
TR/(OE) precharge time	↑TRW	20		20		30		ns	
First SC edge to TR/(OE) HIGH delay time	↑TSD	15		15		15		ns	
Serial output buffer turn-off delay from RAS	↑SDZ	7	40	7	40	7	40	ns	
SC to RAS setup time	↑SRS	25		30		30		ns	
Serial data input to SE delay time	↑SZE	0		0		0		ns	
Serial data input delay from RAS	↑SDD	50		50		50		ns	
Serial data input to RAS delay time	↑SZS	0		0		0		ns	
Serial-input-mode enable (SE) to RAS setup time	↑ESR	0		0		0		ns	
Serial-input-mode enable (SE) to RAS hold time	↑REH	15		15		15		ns	
TR/(OE) HIGH to RAS setup time	↑YS	0		0		0		ns	
TR/(OE) HIGH to RAS hold time	↑YH	15		15		15		ns	
DSF to RAS setup time	↑FSR	0		0		0		ns	
DSF to RAS hold time	↑RFH	15		15		15		ns	
SC to QSF delay time	↑SQD		30		30		30	ns	
SPLIT TRANSFER setup time	↑STS	25		30		30		ns	
SPLIT TRANSFER hold time	↑STH	0		0		0		ns	
RAS to QSF delay time	↑RQD		75		75		75	ns	
DSF to RAS hold time	↑FHR	45		55		70		ns	
DSF to CAS setup time	↑FSC	0		0		0		ns	
DSF to CAS hold time	↑CFH	15		15		20		ns	
TR/OE to QSF delay time	↑TQD		25		25		25	ns	
CAS to QSF delay time	↑CQD		35		35		35	ns	
RAS to first SC delay	↑RSD	80		80		80		ns	
CAS to first SC delay	↑CSD	30		30		30		ns	

MULTI-PORT DRAM

SAM TIMING PARAMETERS

ELECTRICAL CHARACTERISTICS AND RECOMMENDED AC OPERATING CONDITIONS

(Notes 6, 7, 8, 9, 10) ($0^{\circ}\text{C} \leq T_A \leq +70^{\circ}\text{C}$; $V_{CC} = 5V \pm 10\%$)

AC CHARACTERISTICS PARAMETER	SYM	-7		-8		-10		UNITS	NOTES
		MIN	MAX	MIN	MAX	MIN	MAX		
Serial clock-cycle time	¹ SC	25		30		30		ns	
Access time from SC	¹ SAC		22		25		27	ns	24, 28
SC precharge time (SC LOW time)	¹ SP	8		10		10		ns	
SC pulse width (SC HIGH time)	¹ SAS	8		10		10		ns	
Access time from $\overline{\text{SE}}$	¹ SEA		15		15		15	ns	24
$\overline{\text{SE}}$ precharge time	¹ SEP	20		20		20		ns	
$\overline{\text{SE}}$ pulse width	¹ SE	20		20		20		ns	
Serial data-out hold time after SC high	¹ SOH	5		5		5		ns	24, 28
Serial output buffer turn-off delay from $\overline{\text{SE}}$	¹ SEZ	3	12	3	12	3	12	ns	20, 24
Serial data-in setup time	¹ SDS	0		0		0		ns	
Serial data-in hold time	¹ SDH	10		10		10		ns	
Serial input (Write) Enable setup time	¹ SWS	0		0		0		ns	
Serial input (Write) Enable hold time	¹ SWH	15		15		15		ns	
Serial input (Write) disable setup time	¹ SWIS	0		0		0		ns	
Serial input (Write) disable hold time	¹ SWIH	15		15		15		ns	

MULTIPOINT DRAM

NOTES

1. All voltages referenced to V_{SS}.
2. This parameter is sampled. V_{CC} = 5V ±10%, f = 1 MHz.
3. I_{CC} is dependent on cycle rates.
4. I_{CC} is dependent on I/O loading. Specified values are obtained with minimum cycle time and the I/Os open.
5. Enables on-chip refresh and address counters.
6. The minimum specifications are used only to indicate cycle time at which proper operation over the full temperature range (0°C ≤ T_A ≤ 70°C) is assured.
7. An initial pause of 100µs is required after power-up followed by any eight RAS cycles before proper device operation is assured. The eight RAS cycle wake-up should be repeated any time the REF refresh requirement is exceeded.
8. AC characteristics assume T = 5ns.
9. V_{IH} (MIN) and V_{IL} (MAX) are reference levels for measuring timing of input signals. Transition times are measured between V_{IH} and V_{IL} (or between V_{IL} and V_{IH}). Input signals transition between 0V and 3V for AC testing.
10. In addition to meeting the transition rate specification, all input signals must transit between V_{IH} and V_{IL} (or between V_{IL} and V_{IH}) in a monotonic manner.
11. If \overline{CAS} = V_{IH}, DRAM data output (DQ1-DQ4) is High-Z.
12. If \overline{CAS} = V_{IL}, DRAM data output (DQ1-DQ4) may contain data from the last valid READ cycle.
13. DRAM output timing measured with a load equivalent to 2 TTL gates and 100pF. Output reference levels: V_{OH} = 2.0V; V_{OL} = 0.8V.
14. Assumes that t_{RCD} < t_{RCD} (MAX). If t_{RCD} is greater than the maximum recommended value shown in this table, t_{RAC} will increase by the amount that t_{RCD} exceeds the value shown.
15. Assumes that t_{RCD} ≥ t_{RCD} (MAX).
16. If \overline{CAS} is LOW at the falling edge of RAS, DQ will be maintained from the previous cycle. To initiate a new cycle and clear the data out buffer, \overline{CAS} must be pulsed HIGH for t_{CPN}.
17. Operation within the t_{RCD} (MAX) limit ensures that t_{RAC} (MAX) can be met. t_{RCD} (MAX) is specified as a reference point only; if t_{RCD} is greater than the specified t_{RCD} (MAX) limit, then access time is controlled exclusively by t_{CAC}.
18. Operation within the t_{RAD} (MAX) limit ensures that t_{RCD} (MAX) can be met. t_{RAD} (MAX) is specified as a reference point only; if t_{RAD} is greater than the specified t_{RAD} (MAX) limit, then access time is controlled exclusively by t_{AA}.
19. Either t_{RCH} or t_{RRH} must be satisfied for a READ cycle.
20. t_{OD}, t_{OFF} and t_{SEZ} define the time when the output achieves open circuit (V_{OH} -200mV, V_{OL} +200mV). This parameter is sampled and not 100 percent tested.
21. t_{WCS}, t_{RWD}, t_{AWD} and t_{CWD} are restrictive operating parameters in LATE-WRITE, READ-WRITE and READ-MODIFY-WRITE cycles only. If t_{WCS} ≥ t_{WCS} (MIN), the cycle is an EARLY-WRITE cycle and the data output will remain an open circuit throughout the entire cycle, regardless of $\overline{TR}/\overline{OE}$. If t_{WCS} < t_{WCS} (MIN), the cycle is a LATE-WRITE and $\overline{TR}/\overline{OE}$ must control the output buffers during the WRITE to avoid data contention. If t_{RWD} ≥ t_{RWD} (MIN), t_{AWD} ≥ t_{AWD} (MIN) and t_{CWD} ≥ t_{CWD} (MIN), the cycle is a READ-WRITE and the data output will contain data read from the selected cell. If neither of the above conditions is met, the state of the output buffers (at access time and until \overline{CAS} goes back to V_{IH}) is indeterminate but the WRITE will be valid, if t_{OD} and t_{OE}H are met. See the LATE-WRITE AC Timing diagram.
22. These parameters are referenced to \overline{CAS} leading edge in EARLY-WRITE cycles and $\overline{ME}/\overline{WE}$ leading edge in LATE-WRITE or READ-WRITE cycles.
23. During a READ cycle, if $\overline{TR}/\overline{OE}$ is LOW then taken HIGH, DQ goes open. The DQs will go open with \overline{OE} or \overline{CAS} , whichever goes HIGH first.
24. SAM output timing is measured with a load equivalent to 1 TTL gate and 30pF. Output reference levels: V_{OH} = 2.0V; V_{OL} = 0.8V.
25. t_{OD} and t_{OE}H must be met in LATE-WRITE and READ-MODIFY-WRITE cycles (\overline{OE} HIGH during WRITE cycle) in order to ensure that the output buffers will be open during the WRITE cycle. The DQs will provide previously read data if \overline{CAS} remains LOW and \overline{OE} is taken LOW after t_{OE}H is met. If \overline{CAS} goes HIGH prior to \overline{OE} going back LOW, the DQs will remain open.
26. Address (A0-A8) may be changed two times or less while \overline{RAS} = V_{IL}.
27. Address (A0-A8) may be changed once or less while \overline{CAS} = V_{IH} and \overline{RAS} = V_{IL}.
28. t_{SAC} is MAX at 70° C and 4.5V V_{CC}; t_{SOH} is MIN at 0° C and 5.5V V_{CC}. These limits will not occur simultaneously at any given voltage or temperature. t_{SOH} = t_{SAC} - output transition time; this is guaranteed by design.
29. Values in parenthesis apply to the "L" version.

MULTIPORT DRAM

DRAM READ CYCLE

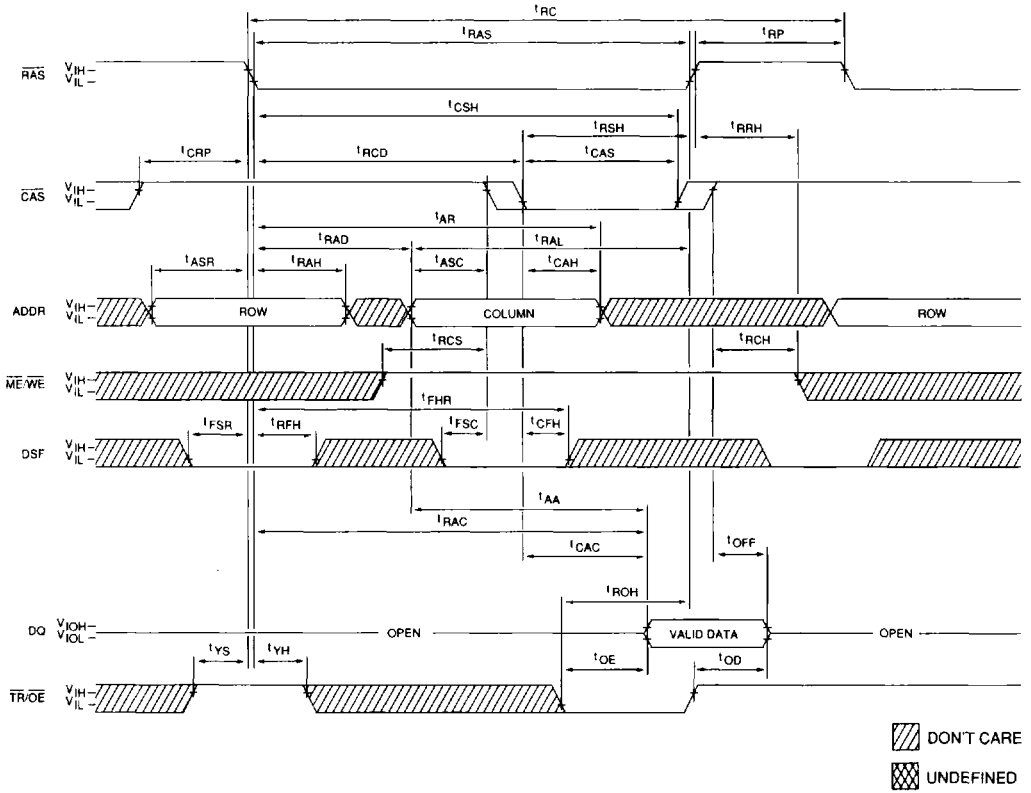

MULTIPOINT DRAM

WRITE CYCLE FUNCTION TABLE ¹

FUNCTION	LOGIC STATES				
	RAS Falling Edge			CAS Falling Edge	
	A ME/WE	B DSF	C DQ (Input)	D DSF	E ² DQ (Input)
Normal DRAM WRITE	1	0	X	0	DRAM Data
NONPERSISTENT (Load and Use) MASKED WRITE to DRAM	0	0	Write Mask	0	DRAM Data (Masked)
PERSISTENT (Use Register) MASKED WRITE to DRAM	0	1	X	0	DRAM Data (Masked)
BLOCK WRITE to DRAM (No Data Mask)	1	0	X	1	Column Mask ³
NONPERSISTENT (Load and Use) MASKED BLOCK WRITE to DRAM	0	0	Write Mask	1	Column Mask ³
PERSISTENT (Use Register) MASKED BLOCK WRITE to DRAM	0	1	X	1	Column Mask ³
Load Mask Register	1	1	X	0	Write Mask
Load Color Register	1	1	X	1	Color Data

- NOTE:**
1. Refer to this function table to determine the logic states of "A", "B", "C", "D" and "E" for the WRITE cycle timing diagrams on the following pages.
 2. CAS or ME/WE, whichever occurs later (Except Block Write).
 3. WE = "don't care" for Block Write. The DQ column-mask data will be latched at the falling edge of CAS, regardless of the state of ME/WE.

MULTIPORT DRAM

DRAM EARLY-WRITE CYCLE 1

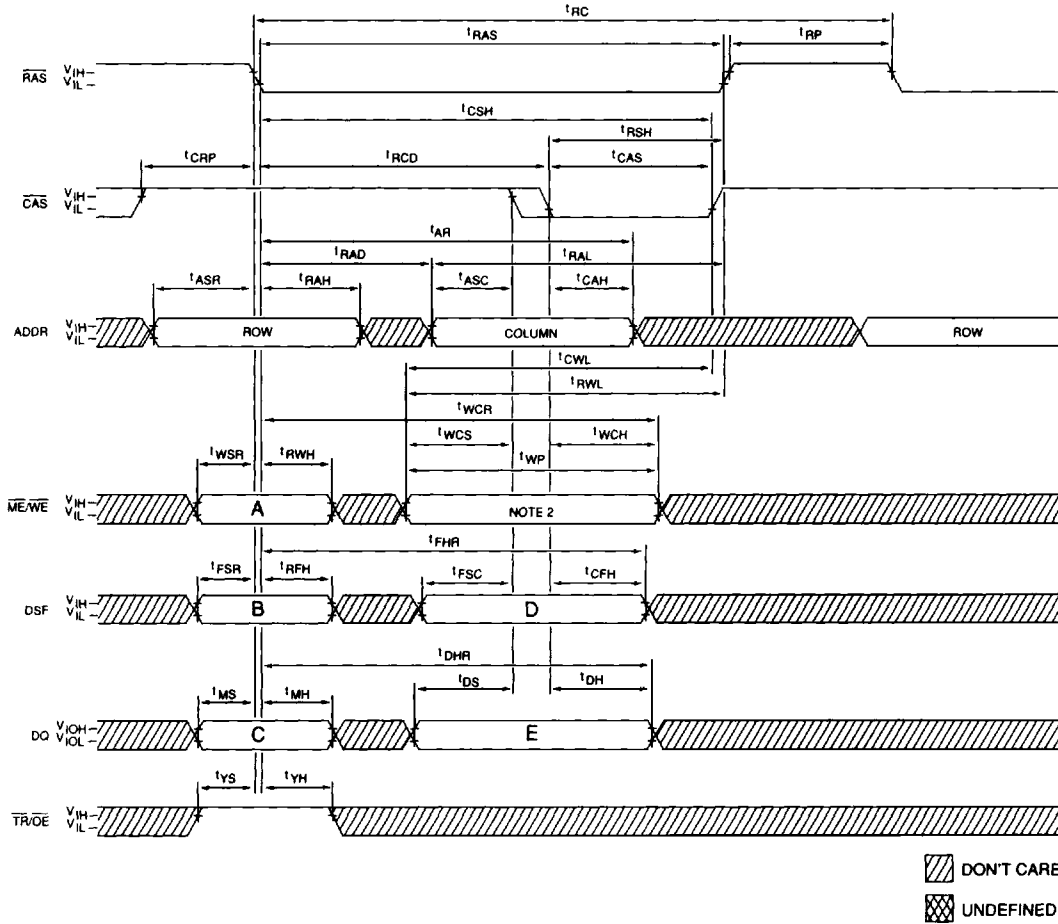

MULTI-PORT DRAM

- NOTE:**
1. The logic states of "A", "B", "C", "D" and "E" determine the type of WRITE operation performed. See the Write Cycle Function Table for a detailed description.
 2. For Block Write, $\overline{ME/WE}$ = "don't care." For all other EARLY-WRITE cycles, $\overline{ME/WE}$ = LOW.

DRAM LATE-WRITE CYCLE ¹

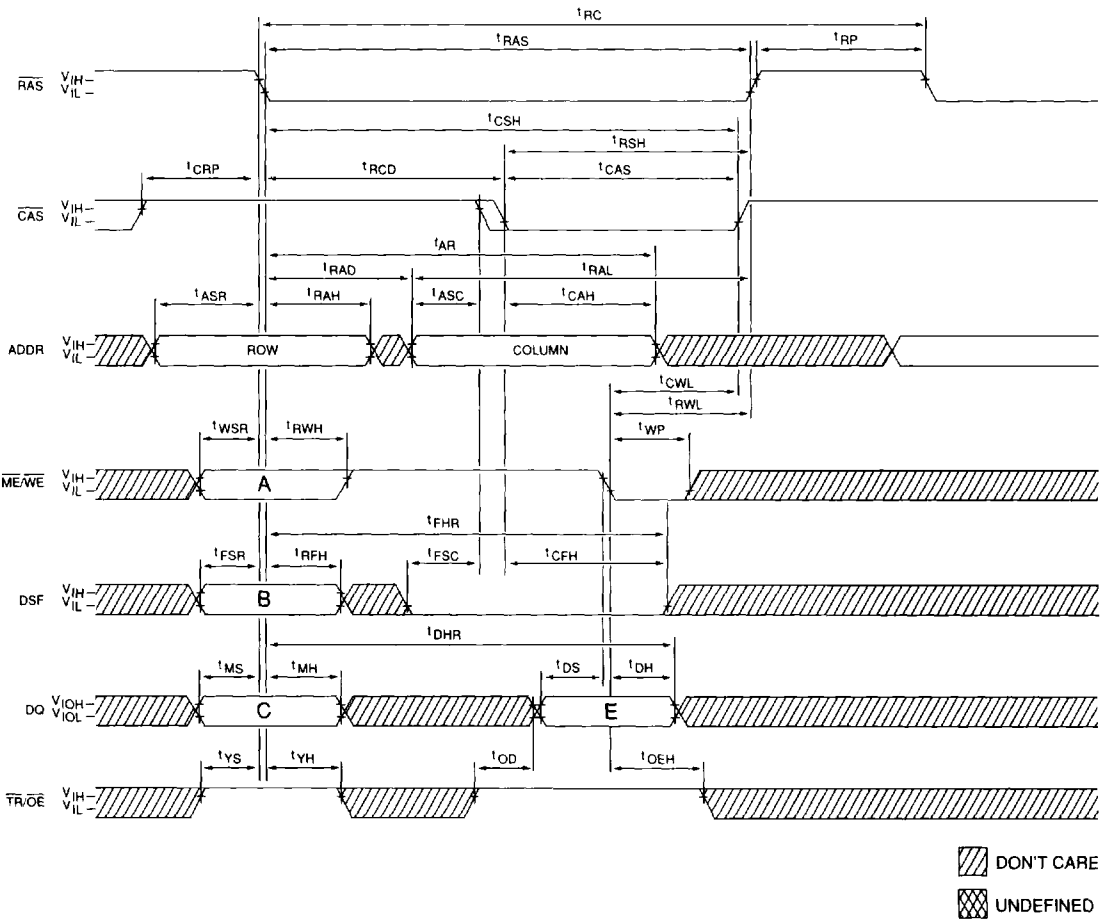

NOTE: 1. The logic states of "A", "B", "C" and "E" determine the type of WRITE operation performed. See the Write Cycle Function Table for a detailed description.

MULTIPOINT DRAM

**DRAM READ-WRITE CYCLE
(READ-MODIFY-WRITE CYCLE)**

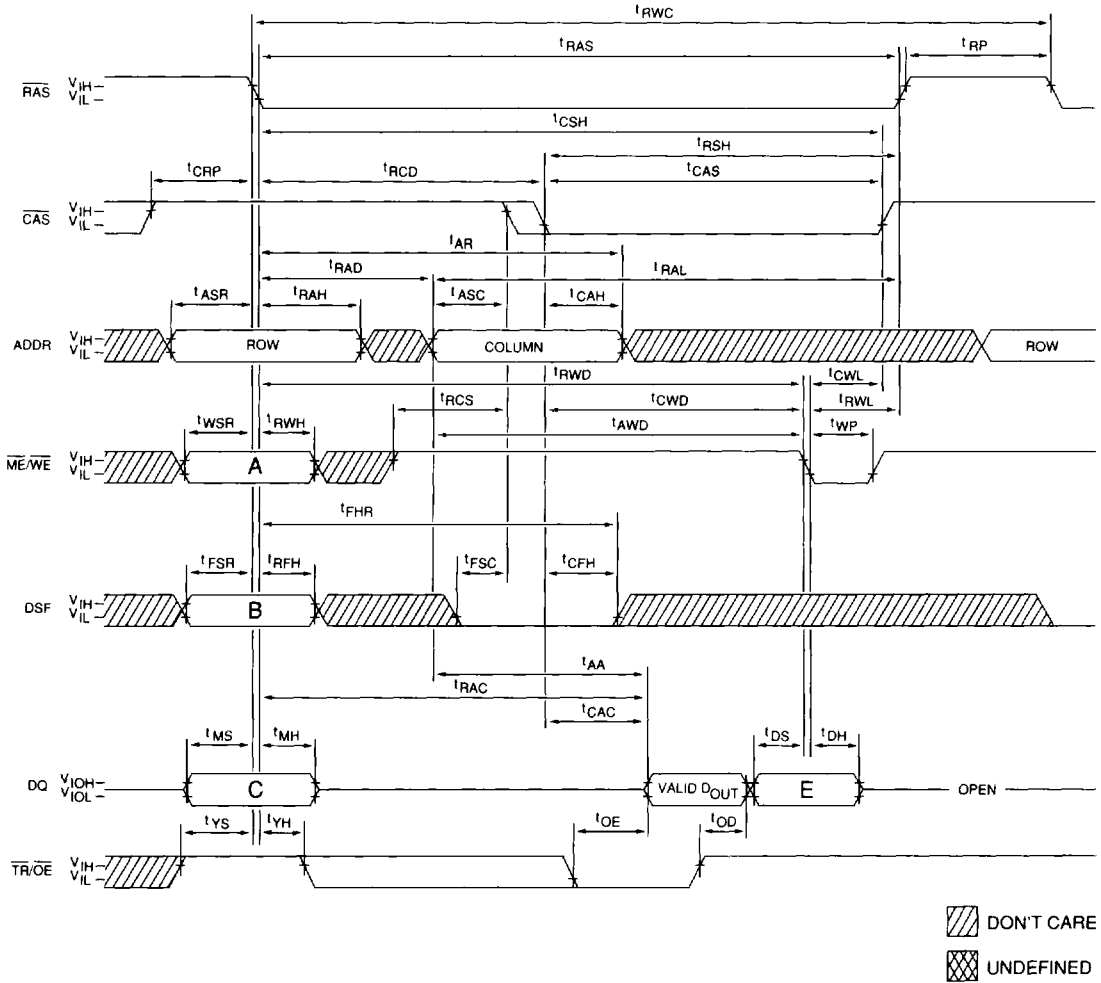

MULTI-PORT DRAM

NOTE: The logic states of "A", "B", "C" and "E" determine the type of WRITE operation performed. See the Write Cycle Function Table for a detailed description.

**DRAM FAST-PAGE-MODE READ-WRITE CYCLE
(READ-MODIFY-WRITE OR LATE-WRITE CYCLES)**

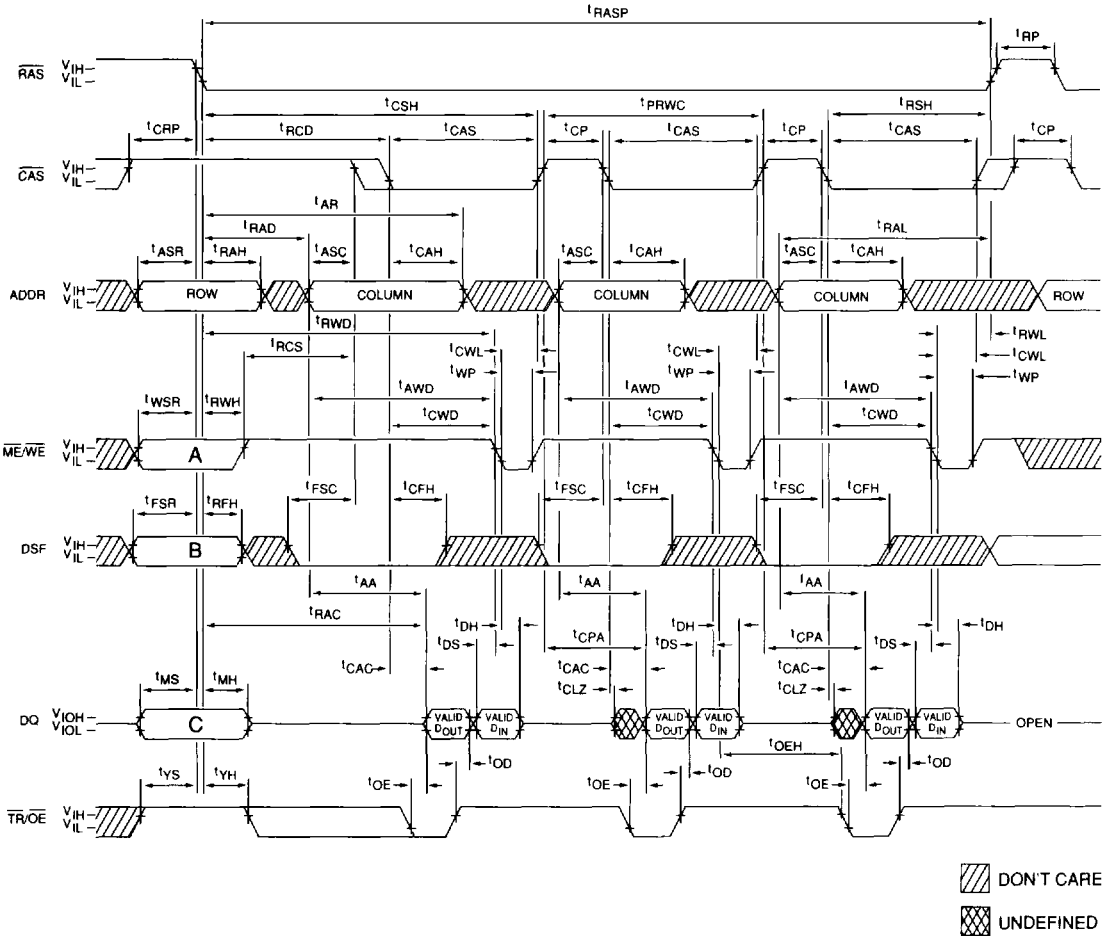

MULTIPORT DRAM

- NOTE:**
1. READ or WRITE cycles can be mixed with READ-MODIFY-WRITE cycles while in FAST PAGE MODE. Use the Write Function Table to determine the proper DSF state for the desired WRITE operation.
 2. The logic states of "A", "B" and "C" determine the type of WRITE operation performed. See the Write Cycle Function Table for a detailed description.

DRAM $\overline{\text{RAS}}$ -ONLY REFRESH CYCLE
(ADDR = A0-A8)

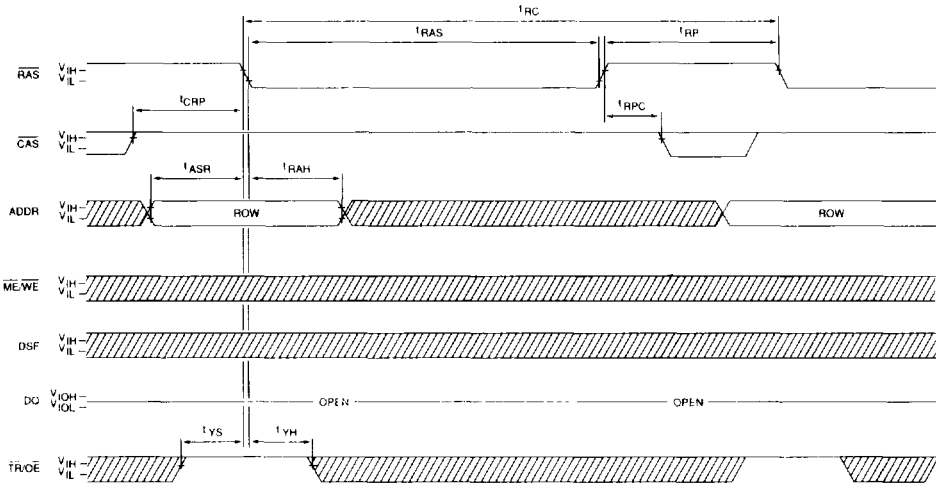

DRAM $\overline{\text{CAS}}$ -BEFORE- $\overline{\text{RAS}}$ REFRESH CYCLE

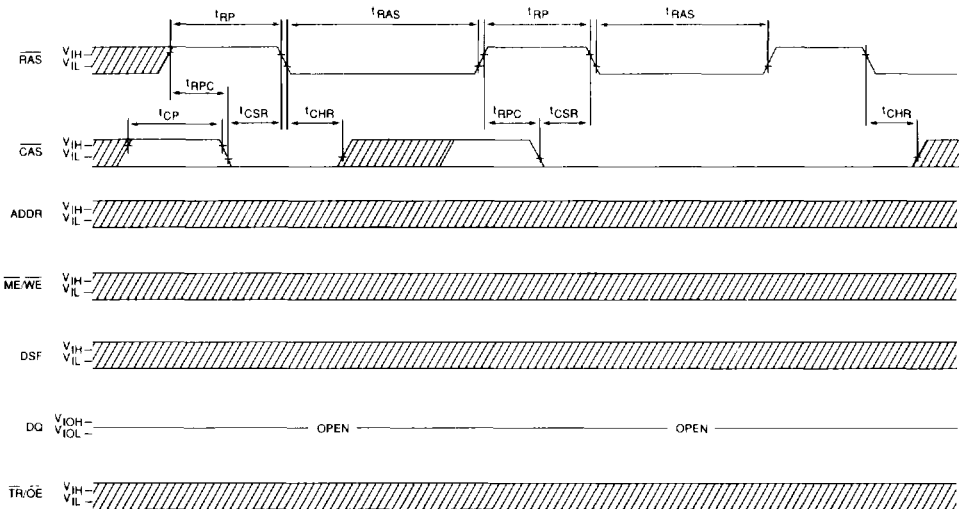

 DON'T CARE
 UNDEFINED

MULTIPORT DRAM

DRAM HIDDEN-REFRESH CYCLE

MULTIPOINT DRAM

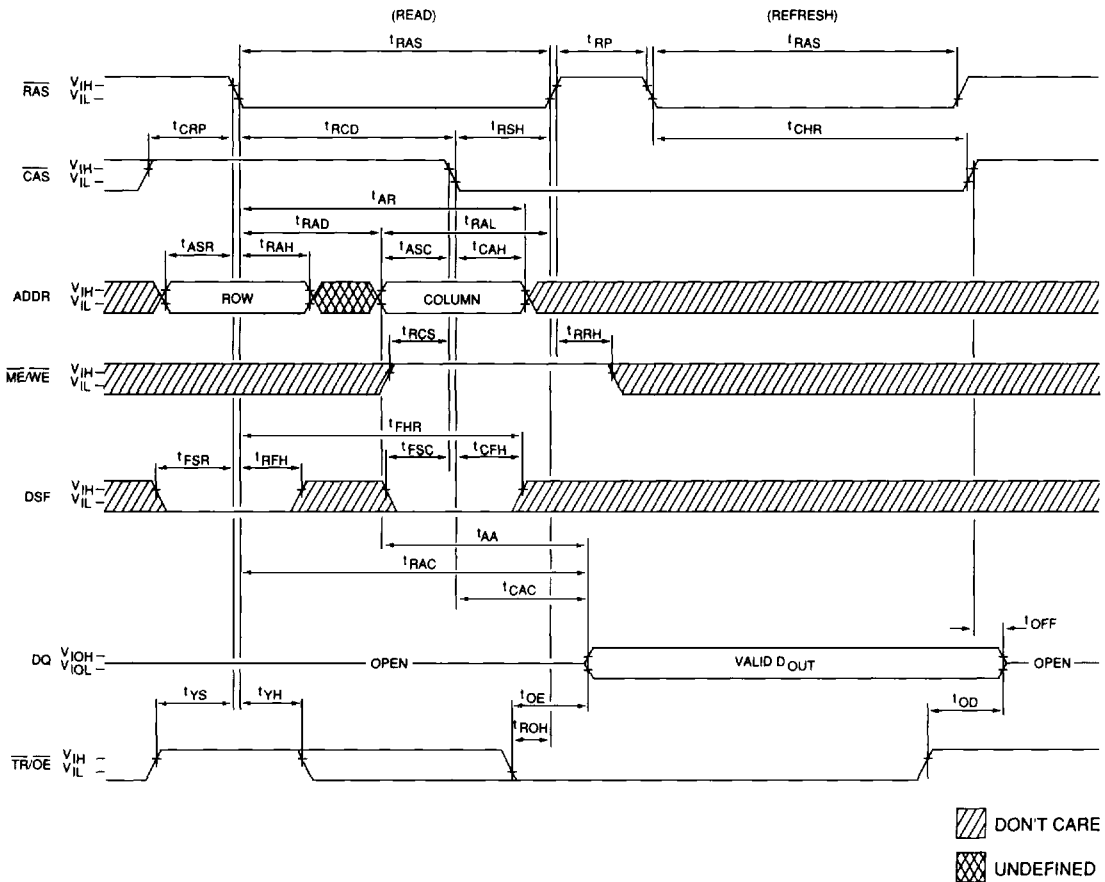

NOTE: A HIDDEN REFRESH may also be performed after a WRITE or TRANSFER cycle. In the WRITE case, ME/WE = LOW (when CAS goes LOW) and TR/OE = HIGH and the DQ pins stay High-Z. In the TRANSFER case, TR/OE = LOW (when RAS goes LOW) and the DQ pins stay High-Z during the refresh period, regardless of TR/OE.

**SPLIT READ TRANSFER
(SPLIT DRAM-TO-SAM TRANSFER)**

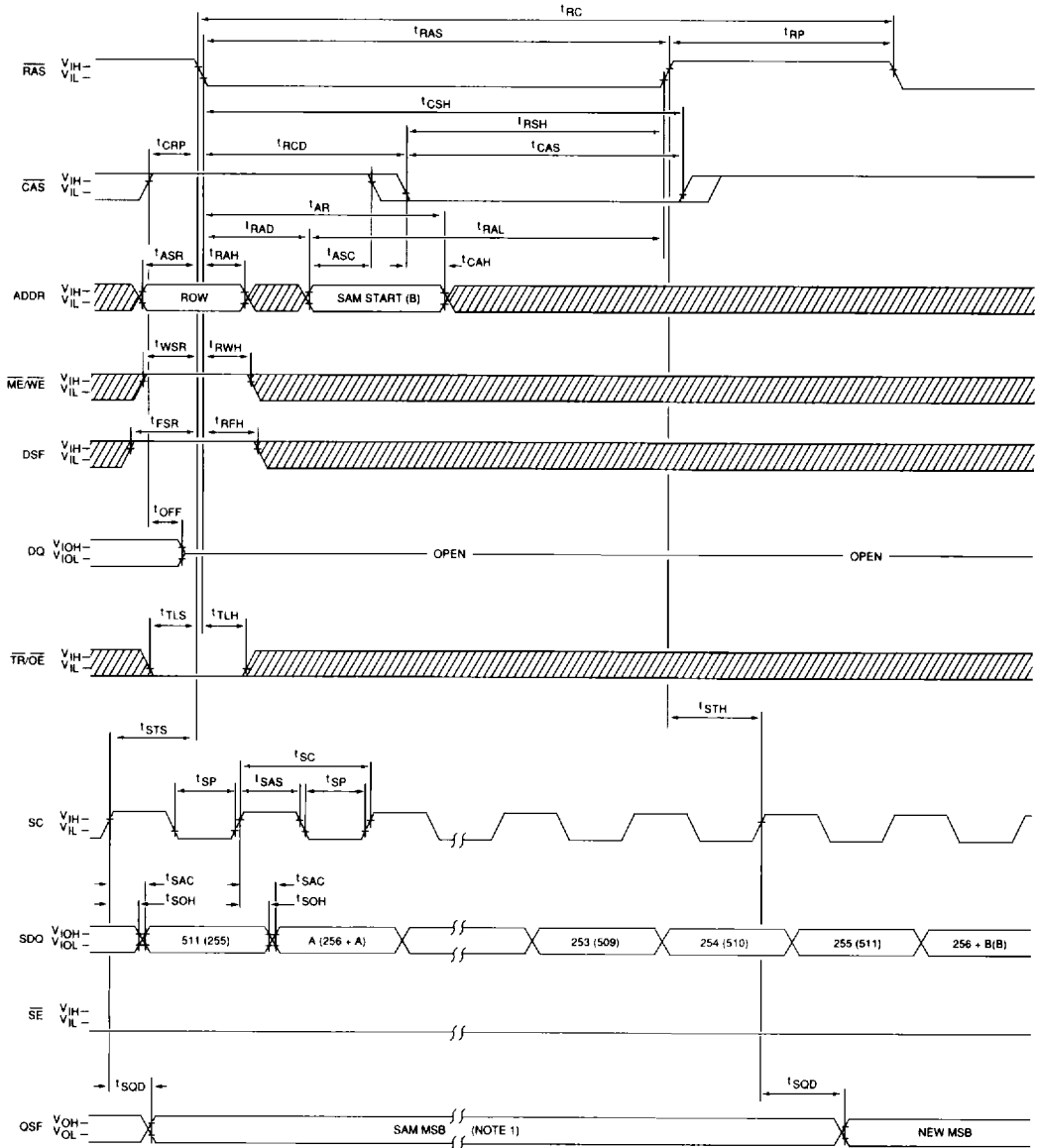

NOTE: 1. QSF = 0 when the Lower SAM (bits 0–255) is being accessed.
QSF = 1 when the Upper SAM (bits 256–511) is being accessed.

▨ DONT CARE
▩ UNDEFINED

MULTIPORT DRAM

**WRITE TRANSFER and PSEUDO WRITE TRANSFER
(SAM-TO-DRAM TRANSFER)**
(When part was previously in the SERIAL OUTPUT mode)

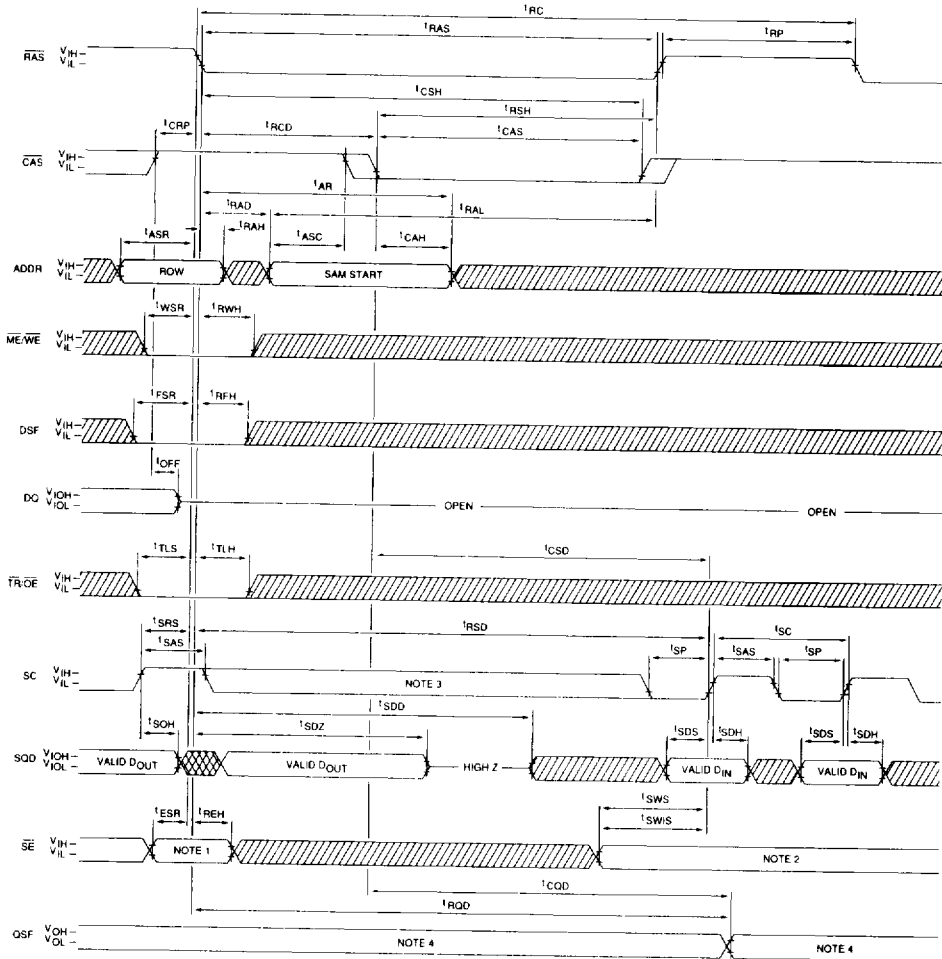

▨ DON'T CARE
▩ UNDEFINED

- NOTE:**
1. If \overline{SE} is LOW, the SAM data will be transferred to the DRAM.
If \overline{SE} is HIGH, the SAM data will not be transferred to the DRAM (SERIAL-INPUT-MODE ENABLE cycle).
 2. \overline{SE} must be LOW to input new serial data, but the serial address register is incremented by SC regardless of \overline{SE} .
 3. There must be no rising edges on the SC input during this time period.
 4. QSF = 0 when the Lower SAM (bits 0–255) is being accessed.
QSF = 1 when the Upper SAM (bits 256–511) is being accessed.

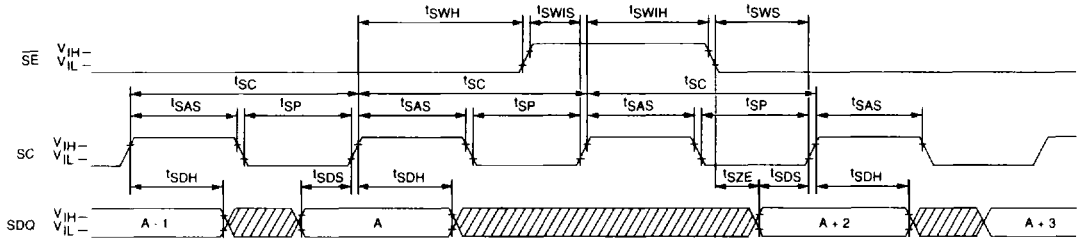

MULTI-PORT DRAM

SAM SERIAL INPUT

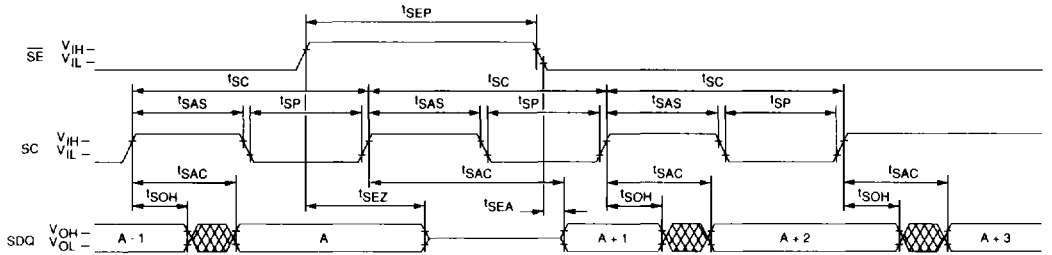

SAM SERIAL OUTPUT



 DON'T CARE
 UNDEFINED

MULTI-PORT DRAM