

SN54F283, SN74F283 4-BIT BINARY FULL ADDERS WITH FAST CARRY

SDFS069A - D2932, MARCH 1987 - REVISED OCTOBER 1993

- Full-Carry Look-Ahead Across the Four Bits
- Systems Achieve Partial Look-Ahead Performance With the Economy of Ripple Carry
- Package Options Include Plastic Small-Outline Packages, Ceramic Chip Carriers, and Standard Plastic and Ceramic 300-mil DIPs

description

The 'F283 is a full adder that performs the addition of two 4-bit binary words. The sum (Σ) outputs are provided for each bit and the resultant carry (C4) output is obtained from the fourth bit.

The device features full internal look-ahead across all four bits generating the carry term C4 in typically 5.7 ns. This capability provides the system designer with partial look-ahead performance at the economy and reduced package count of a ripple-carry implementation.

The adder logic, including the carry, is implemented in its true form. End-around carry can be accomplished without the need for logic or level inversion.

The 'F283 can be used with either all-active-high (positive logic) or all-active-low (negative logic) operands.

The SN54F283 is characterized for operation over the full military temperature range of -55°C to 125°C . The SN74F283 is characterized for operation from 0°C to 70°C .

logic symbol†

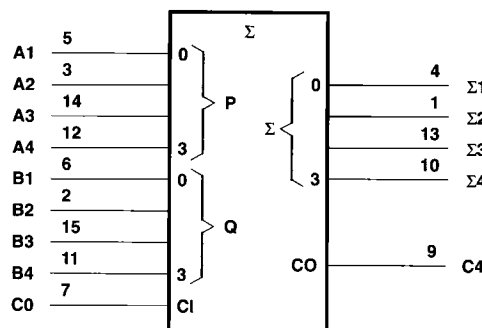

† This symbol is in accordance with ANSI/IEEE Std 91-1984 and IEC Publication 617-12. Pin numbers shown are for the D, J, and N packages.

SN54F283 . . . J PACKAGE
SN74F283 . . . D OR N PACKAGE
(TOP VIEW)

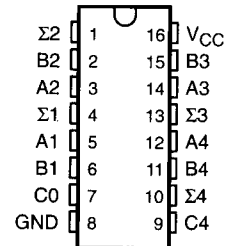

SN54F283 . . . FK PACKAGE
(TOP VIEW)

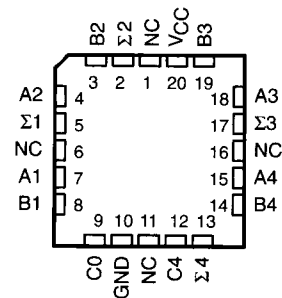

NC - No internal connection

SN54F283, SN74F283 4-BIT BINARY FULL ADDERS WITH FAST CARRY

SDFS069A - D2932, MARCH 1987 - REVISED OCTOBER 1993

logic diagram (positive logic)

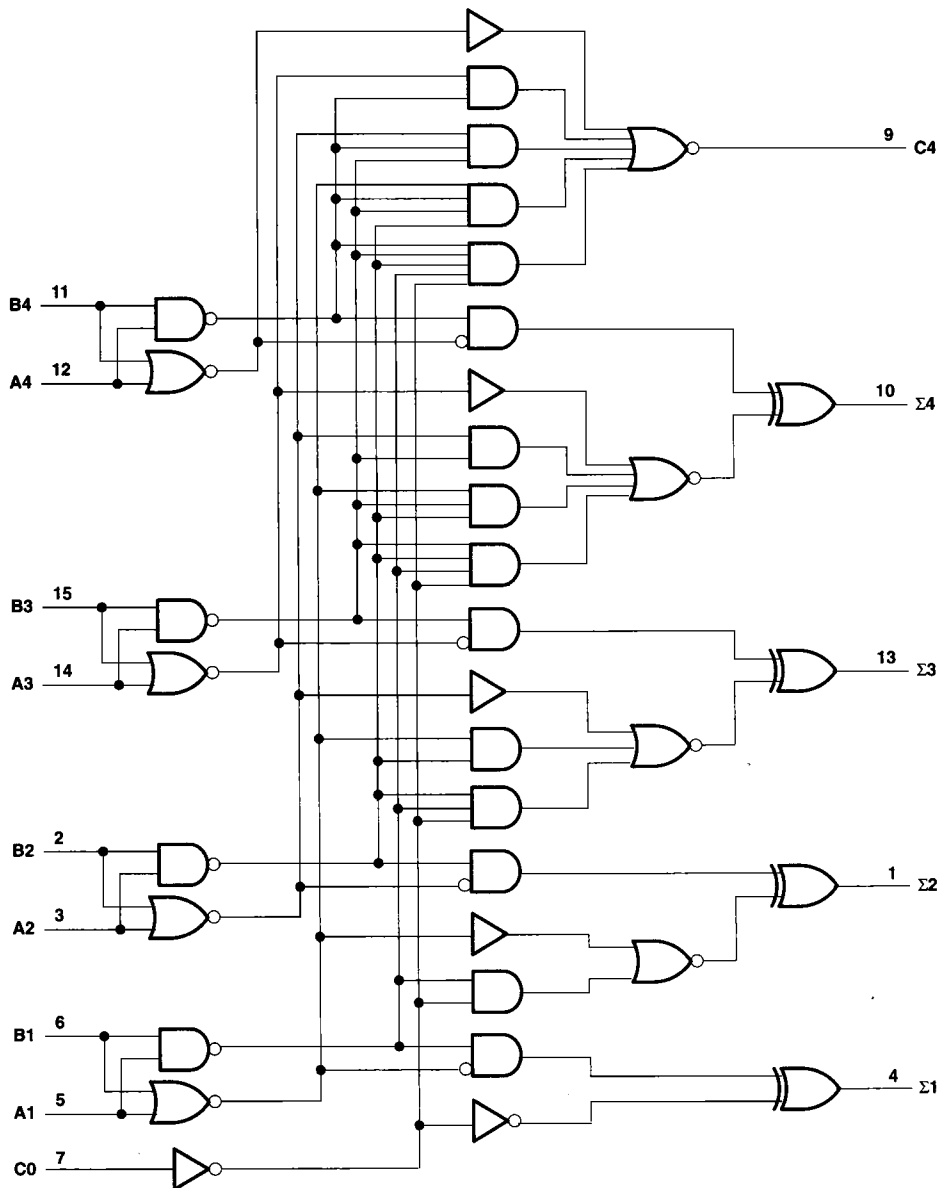

Pin numbers shown are for the D, J, and N packages.

SN54F283, SN74F283
4-BIT BINARY FULL ADDERS
WITH FAST CARRY

SDFS069A - D2932, MARCH 1987 - REVISED OCTOBER 1993

FUNCTION TABLE

INPUTS				OUTPUTS					
				WHEN C0 = L			WHEN C0 = H		
				WHEN C2 = L			WHEN C2 = H		
A1	B1	A2	B2	Σ1	Σ2	C2	Σ1	Σ2	C2
A3	B3	A4	B4	Σ3	Σ4	C4	Σ3	Σ4	C4
L	L	L	L	L	L	L	H	L	L
H	L	L	L	H	L	L	L	H	L
L	H	L	L	L	L	L	L	H	L
H	H	L	L	L	H	L	H	H	L
L	L	H	L	L	H	L	H	H	L
H	L	H	L	H	H	L	L	L	H
L	H	H	L	H	H	L	L	L	H
H	H	H	L	L	L	H	H	L	H
L	L	L	H	L	H	L	H	H	L
H	L	L	H	H	H	L	L	L	H
L	H	L	H	H	H	L	L	L	H
H	H	L	H	L	L	H	H	L	H
L	L	H	H	L	L	H	H	L	H
H	L	H	H	H	L	H	L	H	H
L	H	H	H	H	L	H	L	H	H
H	H	H	H	L	H	H	H	H	H

NOTE: Input conditions at A1, B1, A2, B2, and C0 are used to determine outputs Σ1 and Σ2 and the value of the internal carry C2. The values at C2, A3, B3, A4, and B4 are then used to determine outputs Σ3, Σ4, and C4.

absolute maximum ratings over operating free-air temperature range (unless otherwise noted)†

Supply voltage range, V _{CC}	-0.5 V to 7 V
Input voltage range (see Note 1)	-1.2 V to 7 V
Input current range	-30 mA to 5 mA
Voltage range applied to any output in the high state	-0.5 V to V _{CC}
Current into any output in the low state	40 mA
Operating free-air temperature range: SN54F283	-55°C to 125°C
SN74F283	0°C to 70°C
Storage temperature range	-65°C to 150°C

† Stresses beyond those listed under "absolute maximum ratings" may cause permanent damage to the device. These are stress ratings only and functional operation of the device at these or any other conditions beyond those indicated under "recommended operating conditions" is not implied. Exposure to absolute-maximum-rated conditions for extended periods may affect device reliability.

NOTE 1: The input voltage ratings may be exceeded provided the input current ratings are observed.

SN54F283, SN74F283

4-BIT BINARY FULL ADDERS WITH FAST CARRY

SDFS069A – D2932, MARCH 1987 – REVISED OCTOBER 1993

recommended operating conditions

		SN54F283			SN74F283			UNIT
		MIN	NOM	MAX	MIN	NOM	MAX	
V _{CC}	Supply voltage	4.5	5	5.5	4.5	5	5.5	V
V _{IH}	High-level input voltage	2			2			V
V _{IL}	Low-level input voltage			0.8			0.8	V
I _{IK}	Input clamp current			-18			-18	mA
I _{OH}	High-level output current			-1			-1	mA
I _{OL}	Low-level output current			20			20	mA
T _A	Operating free-air temperature	-55		125	0		70	°C

electrical characteristics over recommended operating free-air temperature range (unless otherwise noted)

PARAMETER	TEST CONDITIONS	SN54F283			SN74F283			UNIT	
		MIN	TYP†	MAX	MIN	TYP†	MAX		
V _{IK}	V _{CC} = 4.5 V, I _I = -18 mA			-1.2			-1.2	V	
V _{OH}	V _{CC} = 4.5 V, I _{OH} = -1 mA	2.5	3.4		2.5	3.4		V	
	V _{CC} = 4.75 V, I _{OH} = -1 mA				2.7				
V _{OL}	V _{CC} = 4.5 V, I _{OL} = 20 mA		0.3	0.5		0.3	0.5	V	
I _I	V _{CC} = 5.5 V, V _I = 7 V			0.1			0.1	mA	
I _{IH}	V _{CC} = 5.5 V, V _I = 2.7 V			20			20	μA	
I _{IL}	Any A or B C0	V _{CC} = 5.5 V, V _I = 0.5 V			-1.2			-1.2	mA
					-0.6			-0.6	
I _{OS} ‡	V _{CC} = 5.5 V, V _O = 0	-60		-150	-60		-150	mA	
I _{CC}	V _{CC} = 5.5 V, V _I = 4.5 V		36	55		36	55	mA	

† All typical values are at V_{CC} = 5 V, T_A = 25°C.

‡ Not more than one output should be shorted at a time, and the duration of the short circuit should not exceed one second.

switching characteristics (see Note 2)

PARAMETER	FROM (INPUT)	TO (OUTPUT)	V _{CC} = 5 V, C _L = 50 pF, R _L = 500 Ω, T _A = 25°C			V _{CC} = 4.5 V to 5.5 V, C _L = 50 pF, R _L = 500 Ω, T _A = MIN to MAX§				UNIT
			F283			SN54F283		SN74F283		
			MIN	TYP	MAX	MIN	MAX	MIN	MAX	
t _{PLH}	C0	Σ	2.7	6.6	9.5	2.7	14	2.7	10.5	ns
t _{PHL}			3.2	6.6	9.5	3.2	14	3.2	10.5	
t _{PLH}	A or B	Σ	3.2	6.6	9.5	3.2	14	3.2	10.5	ns
t _{PHL}			2.7	6.6	9.5	2.7	14	2.7	10.5	
t _{PLH}	C0	C4	2.7	5.3	7.5	2.7	10.5	2.7	8.5	ns
t _{PHL}			2.2	5	7	2.2	10	2.2	8	
t _{PLH}	A or B	C4	2.7	5.3	7.5	2.7	10.5	2.7	8.5	ns
t _{PHL}			2.2	4.9	7	2.2	10	2.2	8	

§ For conditions shown as MIN or MAX, use the appropriate value specified under recommended operating conditions.

NOTE 2: Load circuits and waveforms are shown in Section 1.

