



PIDG

TE Part # 8-34541-1

TE Internal #: 8-34541-1

PIDG SPADE TONGUE TERMINALS

[View on TE.com >](#)

Terminals & Splices > Rings & Spades > PIDG SPADE TONGUE TERMINALS

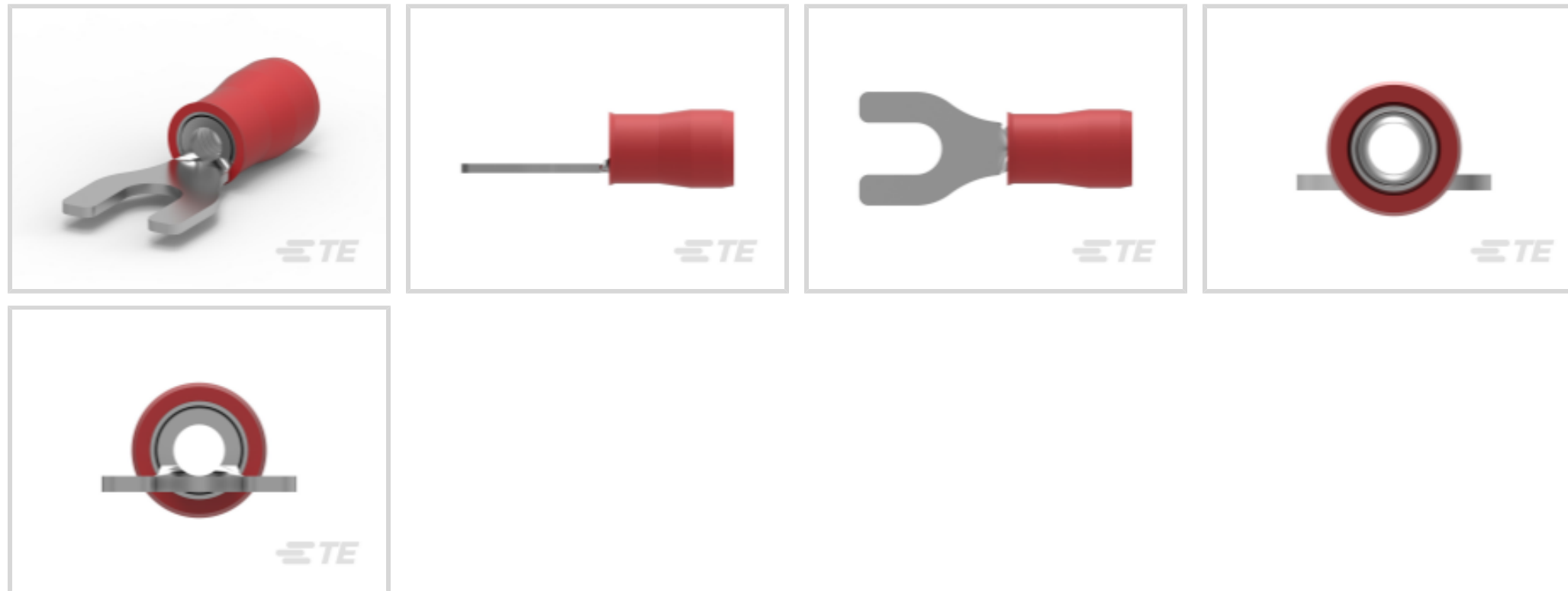

Wire Size: 509 – 3260 CMA

Stud Size: #6, M3.5

Stud Diameter: 3.68 mm [ .145 in ]

[All PIDG SPADE TONGUE TERMINALS \(64\)](#)

Features

Product Type Features

Shape Description	SPADE-020
Stud Size	#6, M3.5
Barrel Type	Closed Barrel
Sealable	No
Insulated	Yes
Wire/Cable Type	Regular Wire
Support Style	Insulation Support

Configuration Features

Number of Holes	1
Terminal Angle	Straight

Electrical Characteristics

Voltage (Max)	300 V
---------------	-------

Body Features

Inspection Slot	No
-----------------	----



Weight per Piece	1.061 g
------------------	---------

Plating Material	Copper, Tin
------------------	-------------

### Contact Features

Terminal Orientation	Straight
----------------------	----------

### Mechanical Attachment

Wire Insulation Support	With
-------------------------	------

### Dimensions

Wire Size	509 – 3260 CMA
-----------	----------------

Stud Diameter	3.68 mm[.145 in]
---------------	------------------

Tongue Thickness	.79 mm[.031 in]
------------------	-----------------

Overall Length	21.48 mm[.85 in]
----------------	------------------

Barrel Inside Diameter	3.68 mm[.145 in]
------------------------	------------------

Wire Insulation Diameter	2.67 – 3.56 mm[.105 – .14 in]
--------------------------	-------------------------------

### Usage Conditions

Operating Temperature Range	105 °C
-----------------------------	--------

### Operation/Application

Heavy Duty	No
------------	----

### Industry Standards

Government Qualified	No
----------------------	----

### Packaging Features

Packaging Quantity	100
--------------------	-----

Packaging Method	Loose Piece
------------------	-------------

### Product Compliance

[For compliance documentation, visit the product page on TE.com>](#)

EU RoHS Directive 2011/65/EU	Compliant
------------------------------	-----------

EU ELV Directive 2000/53/EC	Compliant
-----------------------------	-----------

China RoHS 2 Directive MIIT Order No 32, 2016	No Restricted Materials Above Threshold
---	---

EU REACH Regulation (EC) No. 1907/2006	Current ECHA Candidate List: JAN 2019 (197) Candidate List Declared Against: JUN 2018 (191)
--	--

Halogen Content	BFR/CFR/PVC Free, but Br/Cl >900 ppm in
-----------------	---

other sources.

Solder Process Capability

Not applicable for solder process capability

Product Compliance Disclaimer

This information is provided based on reasonable inquiry of our suppliers and represents our current actual knowledge based on the information they provided. This information is subject to change. The part numbers that TE has identified as EU RoHS compliant have a maximum concentration of 0.1% by weight in homogenous materials for lead, hexavalent chromium, mercury, PBB, PBDE, DBP, BBP, DEHP, DIBP, and 0.01% for cadmium, or qualify for an exemption to these limits as defined in the Annexes of Directive 2011/65/EU (RoHS2). Finished electrical and electronic equipment products will be CE marked as required by Directive 2011/65/EU. Components may not be CE marked. Additionally, the part numbers that TE has identified as EU ELV compliant have a maximum concentration of 0.1% by weight in homogenous materials for lead, hexavalent chromium, and mercury, and 0.01% for cadmium, or qualify for an exemption to these limits as defined in the Annexes of Directive 2000/53/EC (ELV). Regarding the REACH Regulations, TE's information on SVHC in articles for this part number is still based on the European Chemical Agency (ECHA) 'Guidance on requirements for substances in articles' (Version: 2, April 2011), applying the 0.1% weight on weight concentration threshold at the finished product level. TE is aware of the European Court of Justice ruling of September 10th, 2015 also known as O5A (Once An Article Always An Article) stating that, in case of 'complex object', the threshold for a SVHC must be applied to both the product as a whole and simultaneously to each of the articles forming part of its composition. TE has evaluated this ruling based on the new ECHA "Guidance on requirements for substances in articles" (June 2017, version 4.0) and will be updating its statements accordingly.

### Compatible Parts



TE Part # 58433-3  
PRO CR ASSY, RBY IS9252



TE Part # 58423-1  
DIE, RBY IS9252



TE Part # 59824-1  
TETRA-CRIMP HT ASSY



TE Part # 47386  
CERTI-CRIMP PIDG 22-16  
DAHT

### Also in the Series | PIDG



Crimp Terminal Housings  
(1)



Crimp Wire Pins, Tabs &  
Ferrules(41)



Knife Disconnects(11)



PCB Terminals(9)



Portable Crimp Tools(1)



Quick Disconnects(53)



Rings & Spades(868)



Special Purpose Terminals (1)



Splices(48)

## Customers Also Bought

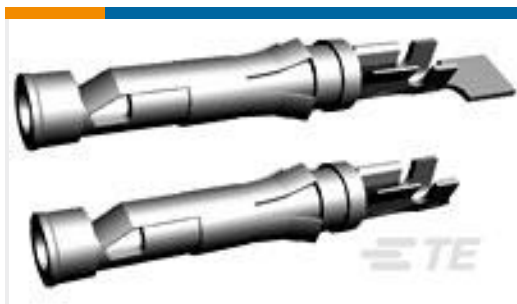

TE Part #1-66105-8  
III+ SKT,24-20,30AU/FL,  
SMPACK



TE Part #6-66506-1  
20 DF PIN CONT,SMALL  
PACK

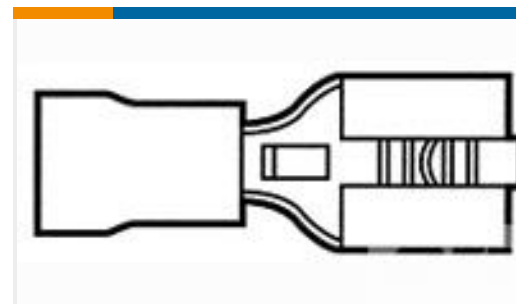

TE Part #8-640905-1  
RECEPT,PIDG FASTON 16-  
14 250

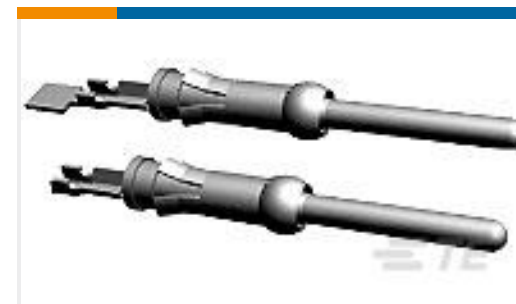

TE Part #1-66103-7  
III+ PIN,24-20,15AU/FL,  
SMPACK



TE Part #7-66504-0  
20 DF SOCKET CONT,  
SMALL PACK



TE Part #8-640903-1  
RECEPT,PIDG FASTON 22-  
18 250

## Documents

### Product Drawings

[PIDG SPD 22-16COMM 22-18MIL 6](#)

English

### CAD Files

Customer View Model

[ENG\\_CVM\\_CVM\\_8-34541-1\\_N.2d\\_dxf.zip](#)

English

[3D PDF](#)



3D

Customer View Model

[ENG\\_CVM\\_CVM\\_8-34541-1\\_N.3d\\_igs.zip](#)

English

Customer View Model

[ENG\\_CVM\\_CVM\\_8-34541-1\\_N.3d\\_stp.zip](#)

English

---

**Product Specifications**

[Application Specification](#)

English

---

**Agency Approvals**

[UL Report](#)

English