

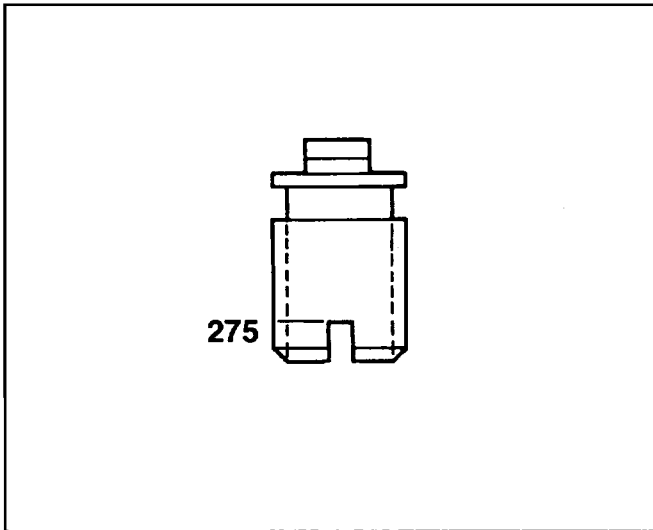

MA46019-MA46048 Series

High Power Pulsed GaAs IMPATT Diodes



Description

These single and double drift pulsed IMPATT diodes have a low-high low or high-low profile. These devices have been shown to be extremely rugged with respect to load mismatch. Short or open circuit loads in any phase can be tolerated indefinitely provided thermal dissipation limits are observed. Rugged and reliable diode construction is assured by using an epitaxial grown doping structure with a high temperature metallization process on Gallium Arsenide.

Features

- HIGH PEAK OUTPUT
 - 30W AT 9.0-10.0 GHz
 - 12W AT 8.0-10.0 GHz
 - 10W AT 5.5-17.5 GHz
- HIGH EFFICIENCY — TYPICALLY 20%
- BURNOUT RESISTANCE TO CIRCUIT MISMATCHES
- HIGH RELIABILITY
- HIGH & LOW DUTY CYCLE OPERATION
- CUSTOM DESIGNS AVAILABLE

Applications

These pulsed IMPATT diodes are ideally suited for driver or final amplifier transmitter applications and are easily power combined in multiple diode oscillators. They are useful in radar systems and active missile seekers.

Specifications @ $T_A = 25^\circ C$

Model Number	Case Style	Operating Frequency Min./Max. (GHz)	Minimum Peak Output (Watts)	Minimum Efficiency (%)	Maximum Thermal Resistance (C/W)	Maximum Operating Current (Amps)
MA46042	111	5.5/ 6.5	10 ⁸	14	8.0	1.5
MA46045	275	8.0/10.0	12 ⁷	17	9.0	1.5
MA46020	275	9.0/10.0	30 ⁶	17	5.5	2.1
MA46019	940	9.0/10.0	24 ⁵	17	5.5	1.4
MA46046	111	9.0/11.0	10 ⁸	12	10.0	2.0
MA46044	275	12.0/16.0	10 ⁷	14	10.0	1.8
MA46047	275	13.0/16.0	10 ⁸	9	10.0	3.5
MA46048	275	16.5/17.5	10 ⁸	14	10.0	2.0

Model Number	Nominal ³ Operating Voltage (Volts)	Nominal Breakdown ³ Voltage (Volts)	Nominal ⁴ Junction Capacitance (pF)
MA46042	80	60	70
MA46045	70	45	60
MA46020	110	75	40
MA46019	110	75	35
MA46046	70	55	60
MA46044	60	35	60
MA46047	50	35	60
MA46048	40	30	40

NOTES:

1. The MA46046 is also available in case style 275.
2. The MA46045, MA46046 diodes are tested in a fixed tuned oscillator near the center of the frequency range, with a maximum average junction temperature rise of 200° C. Customer should specify the center frequency of operation, pulse width and duty cycle when ordering.
3. Breakdown voltage is measured with an I_r of 1 mA.
4. Junction capacitance is measured with a reverse voltage of zero volts at a frequency of 1 MHz.
5. Duty Cycle: 30%; Pulse Width: 1 to 2 μs.
6. Duty Cycle: 10%; Pulse Width: 1 to 4 μs.
7. Duty Cycle: 15 to 30%; Pulse Width: 1 to 5 μs.
8. Duty Cycle: 1 to 10%; Pulse Width: 5 to 15 μs.

MAXIMUM RATINGS

Junction Temperature	
Operating	-65°C to +225°C
Storage	-65°C to +225°C
Voltage	Breakdown Voltage
Soldering Temperature	
(for 5 second maximum)	230°C
Power Dissipation	$\frac{(225^\circ C - T_A)}{R_\theta}$ °C/W

NOTE: Ratings should not be exceeded under either continuous or transient conditions. A single rating may be the limitation, and simultaneous operation at more than one rating, may damage the device. Equipment design should limit current and environmental variations so that the ratings will never be exceeded.

ENVIRONMENTAL RATINGS

Screen/Test Inspection	MIL-STD-750 Method	Conditions/Comments
Temperature, Storage	1031	-65°C to +225°C
Temperature, Operating	1031	-65°C to +225°C
Temperature Cycling	1051	5 Cycles -65°C to +150°C
Shock	2016	500 g's
Vibration	2056	15 g's
Constant Acceleration	2006	20,000 g's
Moisture Resistance	1021	10 days

Typical Performance Curves

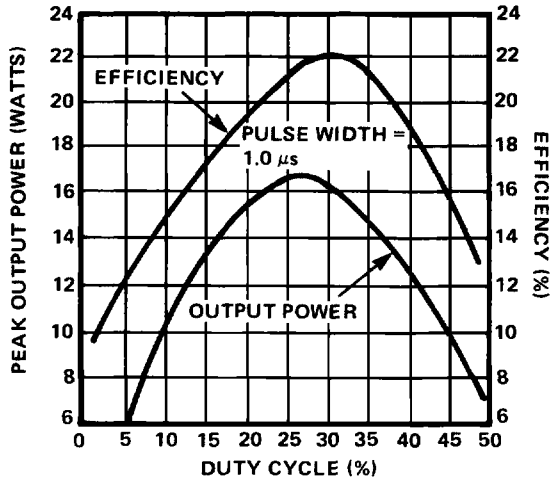

FIGURE 1. Output Power and Efficiency vs. Duty Cycle for an MA46045 Pulsed IMPATT Diode

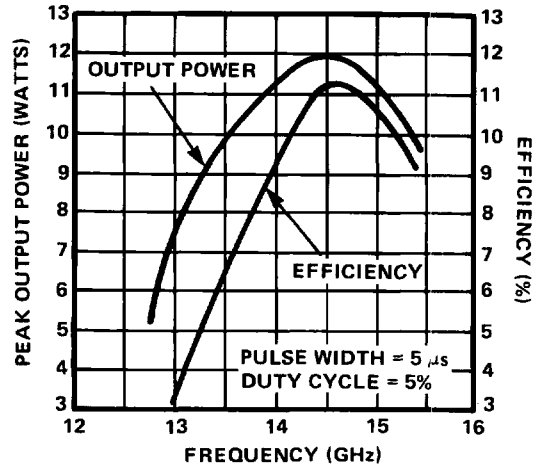

FIGURE 2. Output Power and Efficiency vs. Frequency for an MA46047 Pulsed IMPATT Diode (Diode and Circuit Have Been Optimized for 14.5 GHz)

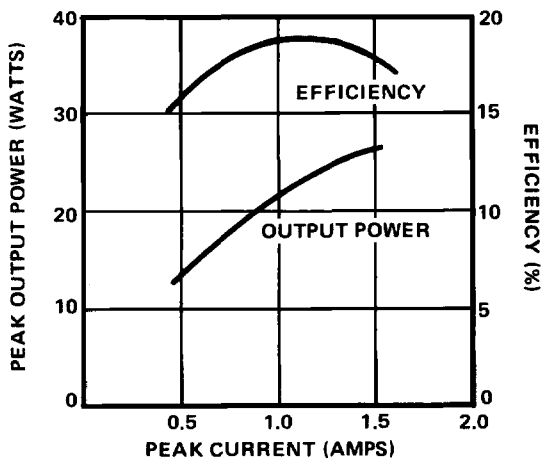

FIGURE 3. Double Drift IMPATT Output Power and Efficiency vs. Peak Current for an MA46019 Pulsed IMPATT Diode

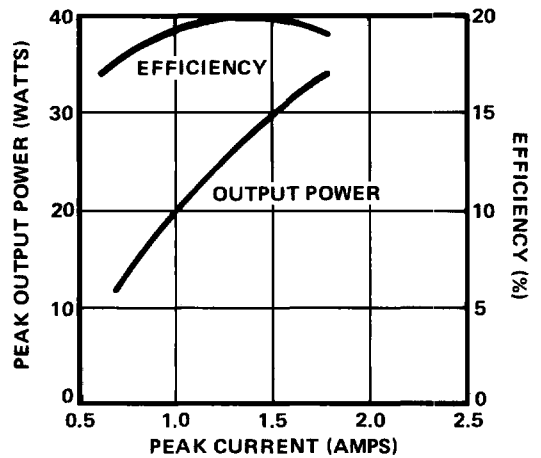
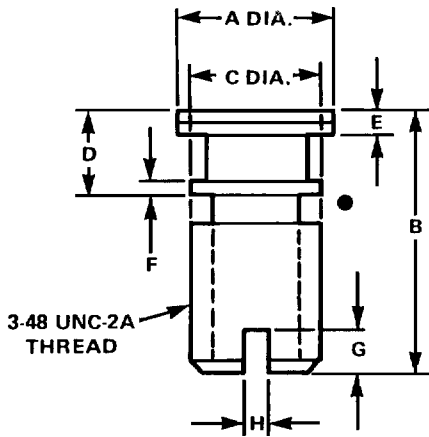

FIGURE 4. Double Drift IMPATT Output Power and Efficiency vs. Peak Current for an MA46020 Pulsed IMPATT Diode

Case Styles

111



DIM.	INCHES		MILLIMETERS	
	MIN.	MAX.	MIN.	MAX.
A	0.119	0.127	3,02	3,23
B	0.188	0.208	4,78	5,28
C	0.098	0.102	2,49	2,59
D	0.057	0.071	1,45	1,80
E	0.016	0.024	0,41	0,61
F	0.009	0.011	0,23	0,28
G	0.025	0.045	0,64	1,14
H	0.015	0.025	0,38	0,64

$C_p = 0.27$ pF Typical
 $L_s = 0.30$ nH Typical

275

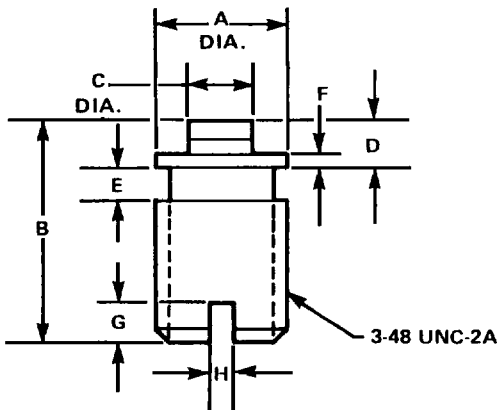

DIM.	INCHES		MILLIMETERS	
	MIN.	MAX.	MIN.	MAX.
A	0.113	0.118	2,87	3,00
B	0.159	0.179	4,04	4,55
C	0.048	0.052	1,22	1,32
D	0.033	0.044	0,84	1,12
E	0.025	0.035	0,64	0,89
F	0.018	0.022	0,46	0,56
G	0.035	0.045	0,89	1,14
H	0.015	0.025	0,38	0,64

$C_p \sim .33$ pF Typical
 $L_s \sim .20$ nH

940

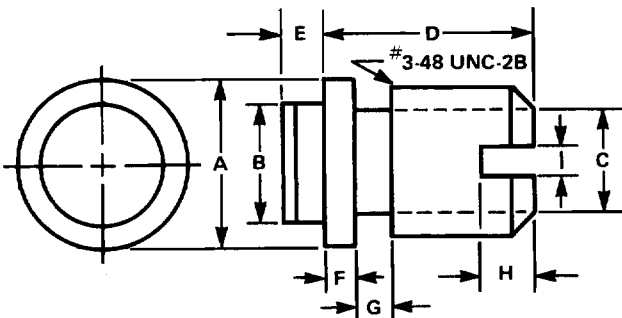

DIM.	INCHES		MILLIMETERS	
	MIN.	MAX.	MIN.	MAX.
A	0.113	0.118	2,87	3,00
B	0.076	0.084	1,93	2,13
C	0.068	0.072	1,73	1,83
D	0.138	0.146	3,51	3,71
E	0.026	0.034	0,66	0,86
F	0.018	0.022	0,46	0,56
G	—	0.020	—	0,51
H	0.035	0.045	0,89	0,114
I	0.015	0.025	0,38	0,64

$C_p \sim .30$ pF Typical
 $L_s \sim .20$ nH