

ASSP Image Processing

30 MHz 8-bit A/D Converter (With AMP)

MB40C218

■ DESCRIPTION

MB40C218 is a high-speed converter using a fast CMOS technology.

■ FEATURES

- Resolution : 8 bit
- Linearity error : $\pm 0.2\%$ (standard)
- Differential linearity error : $\pm 0.12\%$ (standard)
- Maximum conversion rate : 30 MSPS (minimum)
- Supply voltage : Amplifier $+5.00 \pm 0.25$ [V]
A/D converter $+3.00 \pm 0.30$ [V]
- Digital input voltage range : TTL compatible
- Digital output voltage range : 3 V CMOS level compatible (tristate output)
- Analog input voltage range : 0 to 1.5 V (1.5 V_{P-P})
- analog input capacitance : 15 pF (standard)
- Power dissipation : 90 mW (standard: @ AV_{DD5} = 5.00 V, AV_{DD3} = DV_{DD} = 3.00 V)
- Additional features : 1:3 gain amp with dual input selector (bandwidth: 20 MHz, inverting amp)
VRT reference voltage adjustment amp
Power saving capability
Digital output test capability
Analog input offset resistor
- Package : 32-pin plastic QFP

■ PACKAGE

32 pin, Plastic QFP

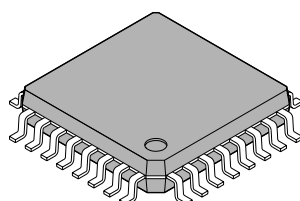

(FPT-32P-M21)

MB40C218

■ PIN ASSIGNMENT

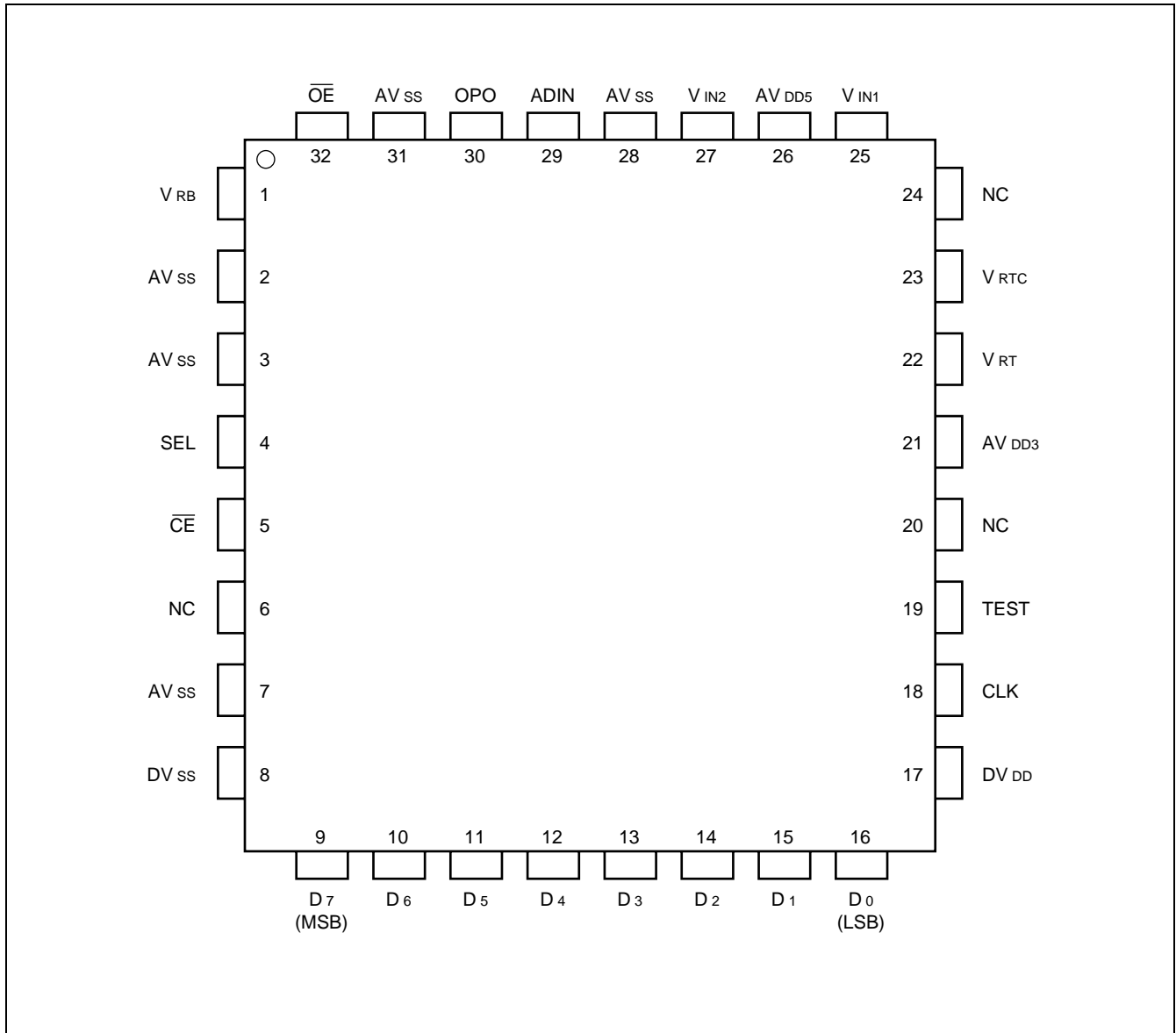

■ DESCRIPTION OF PINS

Pin No.	Symbol	Description	
26	AV _{DD5}	Analog section power supply (+ 5.00 V)	
21	AV _{DD3}	A/D converter analog power supply (+ 3 V)	
17	DV _{DD}	A/D converter digital power supply (+ 3 V)	
2, 3, 7, 28, 31	AV _{SS}	Analog power supply ground pin (0 V)	
8	DV _{SS}	Digital power supply ground pin (0 V)	
9 to 16	D ₇ to D ₀	Digital output pin	
18	CLK	Clock input pin	
29	ADIN	A/D converter analog input pin. Input range is V _{RB} to V _{RT} (0 to 1.5 V) Relationship between analog input and digital output is defined by Test function.	
23	V _{RTC}	Input pin for reference voltage adjustment amp (V _{RT} reference voltage adjustment) V _{RT} is adjusted so that it is 1.5 V with the input pin opened.	
22	V _{RT}	Reference voltage output pin on top side. The voltage fed to V _{RTC} is output.	
1	V _{RB}	Reference voltage input pin on bottom side (0V)	
25	V _{IN1}	Input pin 1 for 1:3 gain amp	Dual input selector for inverting amp
27	V _{IN2}	Input pin 2 for 1:3 gain amp	
30	OPO	Input pin for 1:3 gain (at standby: high impedance)	
4	SEL	Toggle input pin for dual input selector for 1:3 gain amp Input "L": V _{IN1} , Input "H": V _{IN2}	Test function
5	\overline{CE}	Input pin for toggling standby function. Input high signal brings the standby state to the A/D converter, 1:3 gain amp, and reference voltage adjustment amp.	
32	\overline{OE}	Output (D ₇ to D ₀) enable input pin. Input low signal readies digital output. Input high signal induces high-impedance state.	
19	TEST	Test input pin.	
6, 20, 24	N.C.	No connection pins	

The values in parentheses are standard.

■ PRECAUTIONS ON USE

Be sure to ground the pins of AV_{DD5}, AV_{DD3}, DV_{DD} and V_{RT} via high-frequency capacitor.

Place the high-frequency capacitor as close as possible to the pin.

You can minimize the power supply current dissipation due to the internal logic indetermination by making \overline{CE} to high on power turning on.

MB40C218

■ ABSOLUTE MAXIMUM RATINGS

Parameter	Symbol	Rating		Units
		Min.	Max.	
Power supply voltage	AV _{DD5} , AV _{DD3} , DV _{DD}	-0.3	+7.0	V
Input/output voltage	SEL, $\overline{\text{CE}}$, $\overline{\text{OE}}$ CLK, TEST V _{RB} , V _{RT} , V _{RTC} ADIN, V _{IN1} , V _{IN2} OPO	-0.3	AV _{DD5} + 0.3	V
Digital output voltage	D ₀ to D ₇	-0.3	DV _{DD} + 0.3	V
Storage temperature	T _{stg}	-55	+125	°C

Note: Stresses above those listed under "Absolute Maximum Ratings" may cause permanent damage to the device. In the normal operations, it is recommended to use the device in the recommended conditions; exceeding the conditions may affect device reliability.

■ RECOMMENDED OPERATING CONDITIONS

Parameter	Symbol	Value			Units
		Min.	Typ.	Max.	
Power supply voltage	AV _{DD5}	4.75	5.00	5.25	V
	AV _{DD3}	2.70	3.00	3.30	V
	DV _{DD}	2.70	3.00	3.30	V
Analog conversion range	V _{ADIN}	V _{RB}	—	V _{RT}	V
Analog conversion voltage	V _{RT} to V _{RB}	1.05	—	2.10	V
Analog reference input voltage: T	V _{RTC}	1.05	—	2.10	V
Analog reference voltage: B	V _{RB}	0	—	—	V
Digital "H" level input voltage	V _{IHD}	2.1	—	—	V
Digital "L" level input voltage	V _{ILD}	—	—	0.8	V
Digital input current	I _{ID}	—	—	5	μA
Clock frequency	f _{CLK}	0.5	—	30	MHz
"H" level minimum clock pulse width	t _w ⁺	14.0	—	—	ns
"L" level minimum clock pulse width	t _w ⁻	14.0	—	—	ns
Operating temperature range	T _a	-20	—	75	°C

■ ELECTRICAL CHARACTERISTICS

1. DC Characteristics

(1) Analog Section

($AV_{DD5} = 4.75$ to $5.25V$, $AV_{DD3} = DV_{DD} = 2.70$ to $3.30V$, $T_a = -20$ to $+75^{\circ}C$)

Parameter		Symbol	Value			Units
			Min.	Typ.	Max.	
Resolution		—	—	8	—	bit
Linearity error	Conditional DC precision $V_{RT} = 1.5V$ $V_{RB} = 0V$	LE	—	± 0.2	± 0.4	%
Differential linearity error		DLE	—	± 0.12	± 0.2	%
Analog input capacity		C_{ADIN}	—	15	—	pF
Analog supply current		AV_{DD5}	—	7.0	—	mA
		AV_{DD3}	—	16.0	—	mA
Digital supply current		DV_{DD}	—	3.0	—	mA
Standby supply current		I_{STB}	—	100	—	μA
1:3 amp gain	DC to 10 MHz	G_{amp}	9.0	9.5	10.0	dB
	10 to 20 MHz		6.0	6.5	—	dB
$V_{IN1,2}$ bias voltage		$V_{BI1,2}$	—	$AV_{DD5}/2$	—	V
$V_{IN1,2}$ input resistance		$R_{I1,2}$	19	27	35	k Ω
$V_{IN1,2}$ input capacity		$C_{I1,2}$	—	15	—	pF
1:3 gain amp group delay (DC to 10 MHz)		G-Delay	—	—	± 10	ns
1:3 gain amp ($f_{in} = 4, 5, 7$ MHz)	2nd order harmonic distortion	H2	—	—	-50	dB
	3rd order harmonic distortion	H3	—	—	-55	dB
Dual power cross talk ($f_{in} = 7$ MHz)		CT	—	—	-50	dB
Setup voltage with open V_{RTC}		V_{RTC0}	—	$AV_{DD3}/2$	—	V
V_{RTC} input resistance		V_{RTC}	—	25	—	k Ω
ADIN input resistance		R_{ADIN}	—	4.5	—	k Ω

(2) Digital Section

($AV_{DD5} = 4.75$ to $5.25V$, $AV_{DD3} = DV_{DD} = 2.70$ to $3.30V$, $T_a = -20$ to $+75^{\circ}C$)

Parameter		Symbol	Value			Units
			Min.	Typ.	Max.	
Digital "H" level output voltage		V_{OHD}	2.4	—	DV_{DD}	V
Digital "L" level output voltage		V_{OLD}	—	—	0.4	V
Digital "H" level output current		I_{OHD}	-400	—	—	μA
Digital "L" level output current		I_{OLD}	—	—	1.6	mA

MB40C218

(3) Switching Section

($AV_{DD5} = 4.75$ to $5.25V$, $AV_{DD3} = DV_{DD} = 2.70$ to $3.30V$, $T_a = -20$ to $+75^{\circ}C$)

Parameter	Symbol	Value			Unit
		Min.	Typ.	Max.	
Maximum conversion rate	f_s	30	—	—	MSPS
Digital output delay time	t_{pd}	7	13	25	ns

■ TIMING DIAGRAM

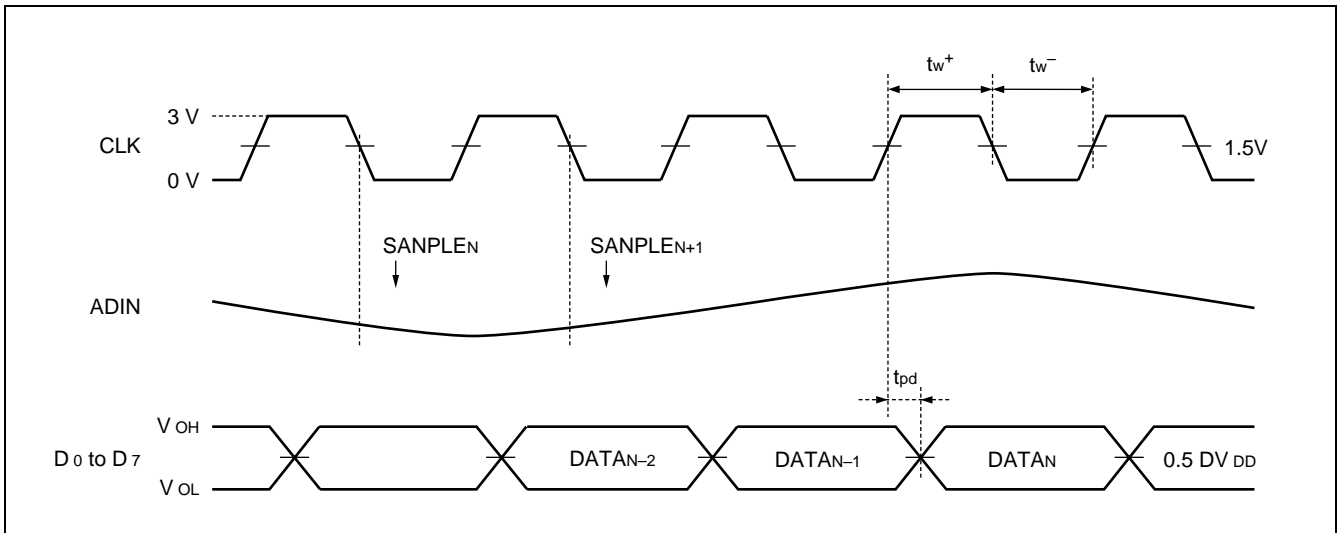

■ DIGITAL OUTPUT BUFFER LOAD CIRCUIT

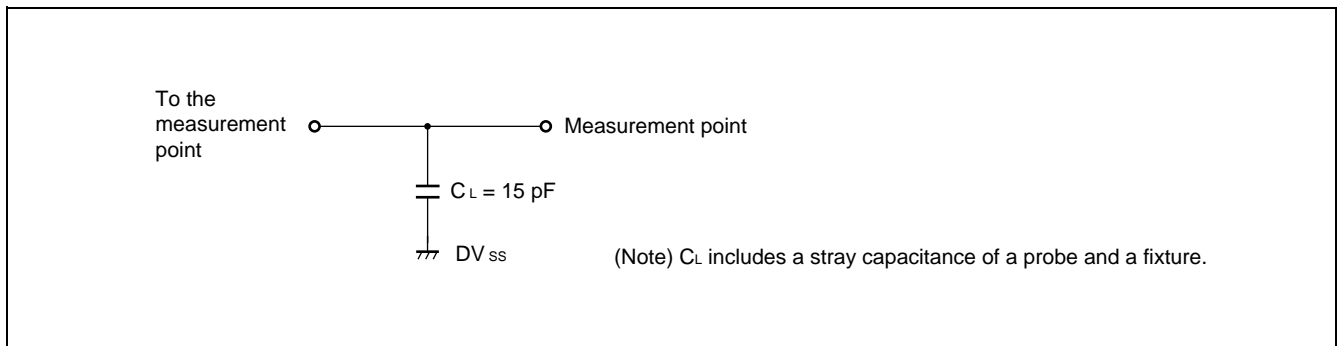

■ TEST FUNCTION

TEST	\overline{CE}	SEL	\overline{OE}	D ₀	D ₁	D ₂	D ₃	D ₄	D ₅	D ₆	D ₇
L	L	X	L	$\overline{D_0}$	$\overline{D_1}$	$\overline{D_2}$	$\overline{D_3}$	$\overline{D_4}$	$\overline{D_5}$	$\overline{D_6}$	$\overline{D_7}$
L	H	X	L	L	L	L	L	L	L	L	L
H	L	X	L	D ₀	D ₁	D ₂	D ₃	D ₄	D ₅	D ₆	D ₇
H	H	L	L	H	L	H	L	H	L	H	L
H	H	H	L	L	H	L	H	L	H	L	H
X	X	X	H	← High impedance →							

■ DIGITAL OUTPUT CODE

ADIN input voltage	Step	Digital output code	
		TEST = "L"	TEST = "H"
V _{RT}	0	0000 0000	1111 1111
•	•	•	•
•	•	•	•
•	127	0111 1111	1000 0000
•	128	1000 0000	0111 1111
•	•	•	•
•	•	•	•
V _{RB}	255	1111 1111	0000 0000

Condition: $\overline{CE} = \overline{OE} = "L"$

MB40C218

■ BLOCK DIAGRAM

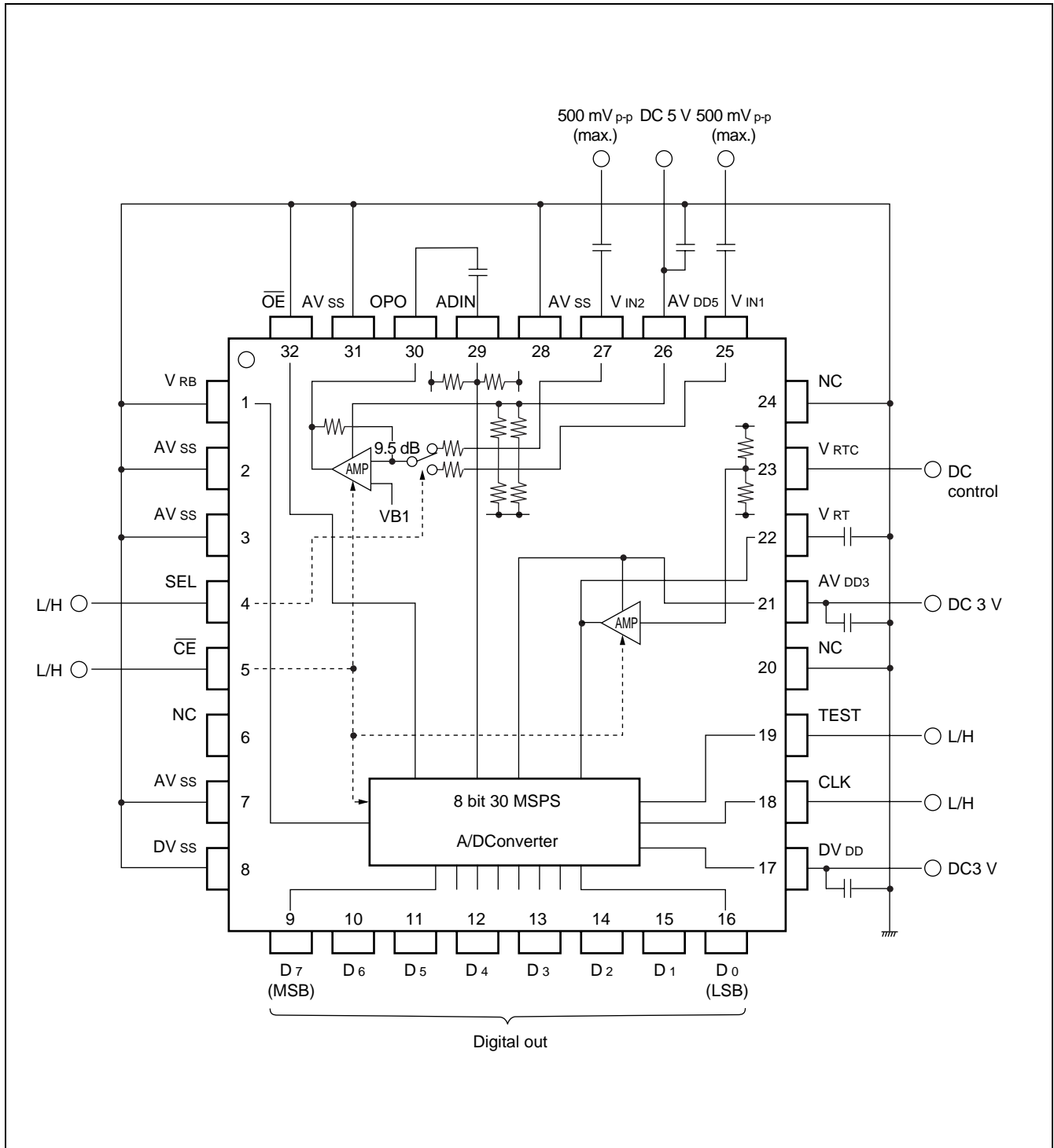

■ ORDERING INFORMATION

Part number	Package	Remark
MB40C218PFQ	32 pin, Plastic QFP (FPT-32P-M02)	

MB40C218

■ PACKAGE DIMENSIONS

32 pin, Plastic QFP
(FPT-32P-M21)

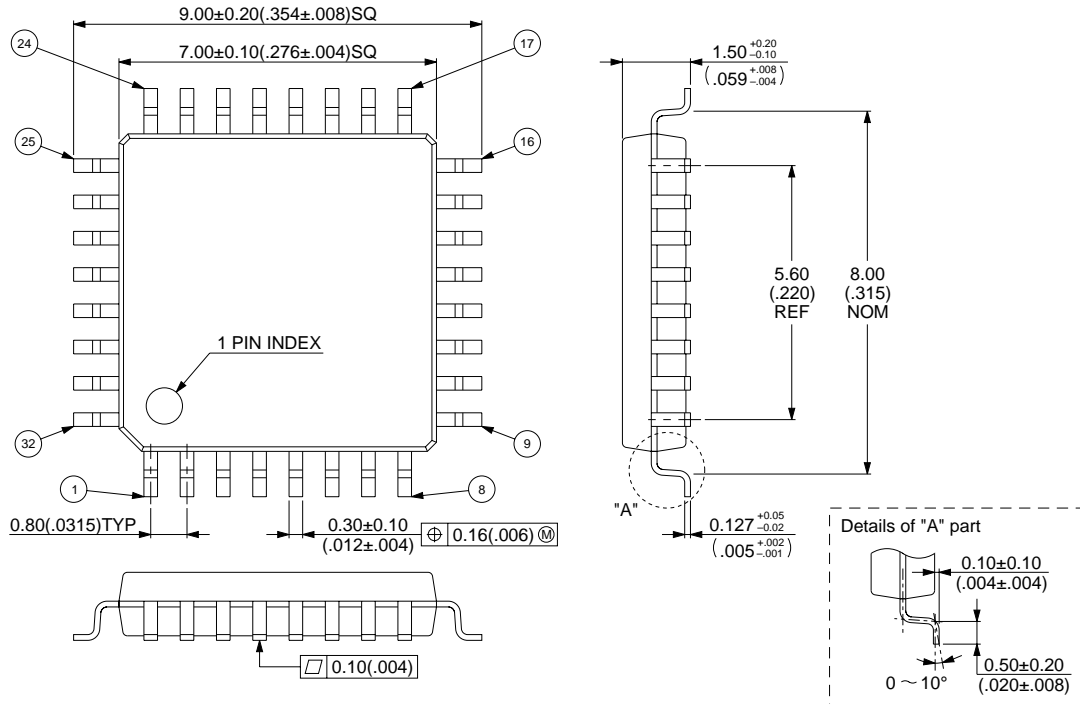

© 1994 FUJITSU LIMITED F32032S-1C-2

Dimensions in mm (inch).

FUJITSU LIMITED

All Rights Reserved.

The contents of this document are subject to change without notice. Customers are advised to consult with FUJITSU sales representatives before ordering.

The information and circuit diagrams in this document are presented as examples of semiconductor device applications, and are not intended to be incorporated in devices for actual use. Also, FUJITSU is unable to assume responsibility for infringement of any patent rights or other rights of third parties arising from the use of this information or circuit diagrams.

The products described in this document are designed, developed and manufactured as contemplated for general use, including without limitation, ordinary industrial use, general office use, personal use, and household use, but are not designed, developed and manufactured as contemplated (1) for use accompanying fatal risks or dangers that, unless extremely high safety is secured, could have a serious effect to the public, and could lead directly to death, personal injury, severe physical damage or other loss (i.e., nuclear reaction control in nuclear facility, aircraft flight control, air traffic control, mass transport control, medical life support system, missile launch control in weapon system), or (2) for use requiring extremely high reliability (i.e., submersible repeater and artificial satellite).

Please note that Fujitsu will not be liable against you and/or any third party for any claims or damages arising in connection with above-mentioned uses of the products.

Any semiconductor devices have an inherent chance of failure. You must protect against injury, damage or loss from such failures by incorporating safety design measures into your facility and equipment such as redundancy, fire protection, and prevention of over-current levels and other abnormal operating conditions.

If any products described in this document represent goods or technologies subject to certain restrictions on export under the Foreign Exchange and Foreign Trade Law of Japan, the prior authorization by Japanese government will be required for export of those products from Japan.

F9703

© FUJITSU LIMITED Printed in Japan