

Features

- Very Fast Read Access Time - 55ns
- Low Power CMOS Operation
8 mA max. Standby
80 mA max. Active at 10 MHz
- Wide Selection of JEDEC Standard Packages including OTP
40-Lead 600-mil Cerdip and OTP Plastic
44-Pad LCC and OTP PLCC
- High Output Drive Capability
- High Reliability CMOS Technology
2000 V ESD Protection
200 mA Latchup Immunity
- Rapid Programming - 100 μ s/word (typical)
- Two-line Control
- CMOS and TTL Compatible Inputs and Outputs
- Integrated Product Identification Code
- Full Military, Industrial and Commercial Temperature Ranges

**1 Megabit
(64K x 16)
High Speed
UV
Erasable
CMOS
EPROM**

4

Description

The AT27HC1024 chip is a high-speed, low-power 1,048,576 bit Ultraviolet Erasable and Electrically Programmable Read Only Memory (EPROM) organized as 64K x 16 bits. It requires only one 5-V power supply in normal read mode operation. Any word can be accessed in less than 55 ns, eliminating the need for speed reducing WAIT states. The by-16 organization makes these parts ideal for high-performance 16 and 32 bit microprocessor and digital signal processor systems.

In read mode, the AT27HC1024 typically consumes 50 mA, while in standby mode supply current is typically less than 1 mA.

The AT27HC1024 come in a choice of industry standard JEDEC-approved packages including; 40-pin DIP in ceramic or one time programmable (OTP) plastic, and 44-pad ceramic leadless chip carrier (LCC), or OTP plastic J-leaded chip carrier (PLCC). All devices feature two line control (\overline{CE} , \overline{OE}) to give designers the flexibility to prevent bus contention.

With high density 64K word storage capability, the AT27HC1024 allows firmware to be stored reliably and to be accessed by the system without the delays of mass storage media. The AT27HC1024 has exceptional CMOS output device capability— source 4 mA and sink 16mA per output.

continued on next page

Preliminary

Pin Configurations

Pin Name	Function
A0-A15	Addresses
O0-O15	Outputs
\overline{CE}	Chip Enable
\overline{OE}	Output Enable
PGM	Program Strobe
NC	No Connect

Note: Both GND pins must be connected.

CDIP, PDIP Top View

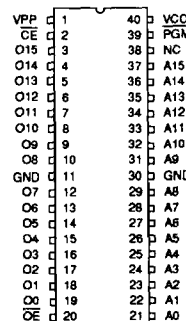

LCC, JLCC, PLCC Top View

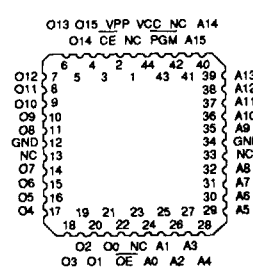

Note: PLCC Package Pins 1 and 23 are DON'T CONNECT.



Description (Continued)

Atmel's 27HC1024 has additional features to ensure high quality and efficient production use. The Rapid Programming Algorithm reduces the time required to program the part and guarantees reliable programming. Programming time is typically only 100 μ s/word. Atmel's high speed single transistor floating poly EPROM cell technology also speeds up programming by eliminating the second program "Os" operation required for two transistor per cell designs. The AT27HC1024 uses the same widely accepted programming algorithm as the AT27C1024. The Integrated Product Identification Code electronically identifies the device and manufacturer. This feature is used by industry standard programming equipment to select the proper programming algorithms and voltages.

Erase Characteristics

The entire memory array of the AT27HC1024 is erased (all outputs read as V_{OH}) after exposure to ultraviolet light at a wavelength of 2537 \AA . Complete erasure is assured after a minimum of 20 minutes exposure using 12,000 μ W/cm² intensity lamps spaced one inch away from the chip. Minimum erase time for lamps at other intensity ratings can be calculated from the minimum integrated erasure dose of 15 W-sec/cm². To prevent unintentional erasure, an opaque label is recommended to cover the clear window on any UV erasable EPROM which will be subjected to continuous fluorescent indoor lighting or sunlight.

Block Diagram

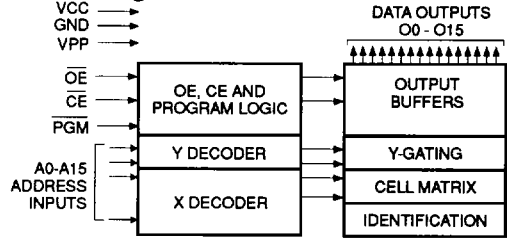

Absolute Maximum Ratings*

Temperature Under Bias	-55°C to +125°C
Storage Temperature	-65°C to +150°C
Voltage on Any Pin with Respect to Ground.....	-2.0 V to +7.0 V ⁽¹⁾
Voltage on A9 with Respect to Ground	-2.0 V to +14.0 V ⁽¹⁾
V _{PP} Supply Voltage with Respect to Ground.....	-2.0 V to +14.0 V ⁽¹⁾
Integrated UV Erase Dose.....	7258 W-sec/cm ²

*NOTICE: Stresses beyond those listed under "Absolute Maximum Ratings" may cause permanent damage to the device. This is a stress rating only and functional operation of the device at these or any other conditions beyond those indicated in the operational sections of this specification is not implied. Exposure to absolute maximum rating conditions for extended periods may affect device reliability.

Notes:

1. Minimum voltage is -0.6 V dc which may undershoot to -2.0 V for pulses of less than 20 ns. Maximum output pin voltage is $V_{CC}+0.75$ V dc which may overshoot to +7.0 V for pulses of less than 20 ns.

Operating Modes

Mode \ Pin	\overline{CE}	\overline{OE}	PGM	A _i	V _{PP}	V _{CC}	Outputs
Read	V _{IL}	V _{IL}	X ⁽¹⁾	A _i	X	V _{CC}	DOUT
Output Disable	X	V _{IH}	X	X	X	V _{CC}	High Z
Standby	V _{IH}	X	X	X	X ⁽⁵⁾	V _{CC}	High Z
Rapid Program ⁽²⁾	V _{IL}	V _{IH}	V _{IL}	A _i	V _{PP}	V _{CC}	D _{IN}
PGM Verify	V _{IL}	V _{IL}	V _{IH}	A _i	V _{PP}	V _{CC}	DOUT
PGM Inhibit	V _{IH}	X	X	X	V _{PP}	V _{CC}	High Z
Product Identification ⁽⁴⁾	V _{IL}	V _{IL}	X	A ₉ =V _{IH} ⁽³⁾ A ₀ =V _{IH} or V _{IL} A ₁ -A ₁₅ =V _{IL}	V _{CC}	V _{CC}	Identification Code

- Notes:
1. X can be V_{IL} or V_{IH}.
 2. Refer to Programming characteristics.
 3. V_{IH} = 12.0 \pm 0.5 V.
 4. Two identifier bytes may be selected. All A_i inputs are held low (V_{IL}), except A₉ which is set to V_{IH}

5. Standby V_{CC} current (I_{SB}) is specified with V_{PP}=V_{CC}. V_{CC} > V_{PP} will cause a slight increase in I_{SB}.

D.C. and A.C. Operating Conditions for Read Operation

		AT27HC1024		
		-55	-70	-90
Operating Temperature (Case)	Com.	0°C - 70°C	0°C - 70°C	0°C - 70°C
	Ind.		-40°C - 85°C	-40°C - 85°C
	Mil.		-55°C - 125°C	-55°C - 125°C
V _{CC} Power Supply		5 V ± 5%	5 V ± 10%	5 V ± 10%

4

D.C. and Operating Characteristics for Read Operation

Symbol	Parameter	Condition	Min	Max	Units
I _{LI}	Input Load Current	V _{IN} = -0.1 V to V _{CC} +1 V		5	μA
I _{LO}	Output Leakage Current	V _{OUT} = -0.1 V to V _{CC} +0.1 V		10	μA
I _{PP1} (2)	V _{PP} (1) Read/Standby Current	V _{PP} = 3.8 to V _{CC} +0.3 V		10	μA
I _{SB}	V _{CC} (1) Standby Current	I _{SB1} (CMOS) CĒ = V _{CC} -0.3 to V _{CC} +1.0 V	Com.	8	mA
			Ind., Mil.	10	mA
		I _{SB2} (TTL) CĒ = 2.0 to V _{CC} +1.0 V	Com.	17	mA
			Ind., Mil.	20	mA
I _{CC}	V _{CC} Active Current	f = 10 MHz, I _{OUT} = 0 mA, CĒ = V _{IL}	Com.	80	mA
			Ind., Mil.	90	mA
V _{IL}	Input Low Voltage		-0.6	0.8	V
V _{IH}	Input High Voltage		2.0	V _{CC} +1	V
V _{OL}	Output Low Voltage	I _{OL} = 16 mA		.45	V
V _{OH}	Output High Voltage	I _{OH} = -100 μA		V _{CC} -0.3	V
		I _{OH} = -4.0 mA		2.4	V

Notes: 1. V_{CC} must be applied simultaneously or before V_{PP}, and removed simultaneously or after V_{PP}.

2. V_{PP} may be connected directly to V_{CC}, except during programming. The supply current would then be the sum of I_{CC} and I_{PP}.

A.C. Characteristics for Read Operation

			AT27HC1024						
			-55		-70		-90		
Symbol	Parameter	Condition	Min	Max	Min	Max	Min	Max	Units
t _{ACC} (3)	Address to Output Delay	CĒ = CĒE Com.		55		70		90	ns
		= V _{IL} Ind., Mil.				70		90	ns
t _{CE} (2)	CĒE to Output Delay	CĒE = V _{IL}		55		70		90	ns
t _{OE} (2,3)	CĒE to Output Delay	CĒE = V _{IL}		30		30		30	ns
t _{DF} (4,5)	CĒE High to Output Float	CĒE = V _{IL}		10		15		20	ns
t _{OH}	Output Hold from Address, CĒE or CĒE, whichever occurred first	CĒE = CĒE = V _{IL}	0		0		0		ns

Notes: 2, 3, 4, 5. - see AC Waveforms for Read Operation.

A.C. Waveforms for Read Operation ⁽¹⁾

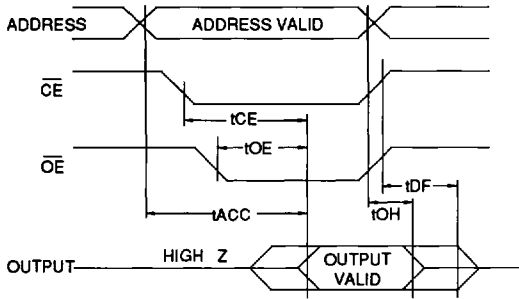

Notes:

1. Timing measurement reference is 1.5 V. Input AC driving levels are 0.0 V and 3.0 V, unless otherwise specified. $C_L = 30$ pF, add 6 ns for $C_L = 100$ pF.
2. t_{DF} is specified from \overline{OE} . t_{DF} is measured at $V_{OH}-0.5$ V or $V_{OL}+0.5$ V with $C_L = 5$ pF.
3. \overline{OE} may be delayed up to t_{CE-tOE} after the falling edge of \overline{CE} without impact on t_{CE} .
4. \overline{OE} may be delayed up to $t_{ACC-tOE}$ after the address is valid without impact on t_{ACC} .
5. This parameter is only sampled and is not 100% tested.

Input Test Waveforms and Measurement Levels

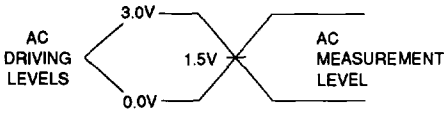

$t_r, t_f < 5$ ns (10% to 90%)

Output Test Load

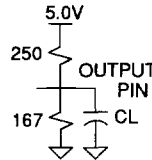

Note: $C_L = 30$ pF including jig capacitance.

Pin Capacitance ($f = 1$ MHz $T = 25^\circ\text{C}$) ⁽¹⁾

	Typ	Max	Units	Conditions
C_{IN}	4	10	pF	$V_{IN} = 0$ V
C_{OUT}	8	12	pF	$V_{OUT} = 0$ V

Notes: 1. Typical values for nominal supply voltage. This parameter is only sampled and is not 100% tested.

Programming Waveforms ⁽¹⁾

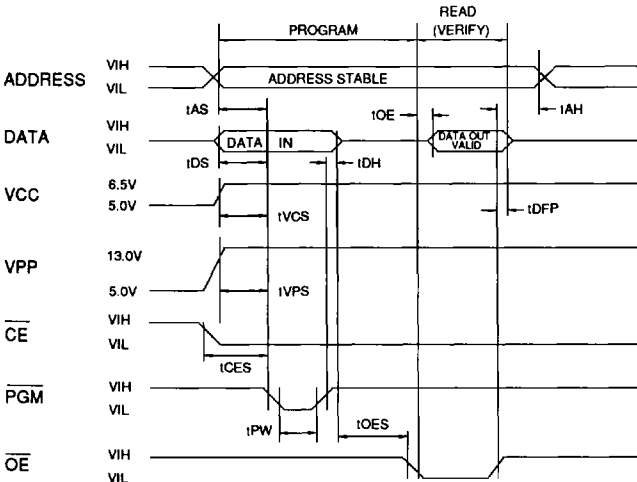

Notes:

1. The Input Timing Reference is 0.0 V for V_{IL} and 3.0 V for V_{IH} .
2. t_{OE} and t_{DFP} are characteristics of the device but must be accommodated by the programmer.
3. When programming the AT27HC1024 a 0.1- μF capacitor is required across V_{PP} and ground to suppress spurious voltage transients.

D.C. Programming Characteristics

$T_A = 25 \pm 5^\circ\text{C}$, $V_{CC} = 6.5 \pm 0.25\text{ V}$, $V_{PP} = 13.0 \pm 0.25\text{ V}$

Symbol	Parameter	Test Conditions	Limits		Units
			Min	Max	
I_L	Input Load Current	$V_{IN}=V_{IL}, V_{IH}$	10		μA
V_{IL}	Input Low Level	(All Inputs)	-0.6	0.8	V
V_{IH}	Input High Level		2.0	$V_{CC}+1$	V
V_{OL}	Output Low Volt.	$I_{OL}=16\text{mA}$.45		V
V_{OH}	Output High Volt.	$I_{OH}=-4\text{mA}$	2.4		V
I_{CC2}	V_{CC} Supply Current (Program and Verify)		60		mA
I_{PP2}	V_{PP} Supply Current	$\overline{CE}=\overline{PGM}=V_{IL}$	40		mA
V_{ID}	A9 Product Identification Voltage		11.5	12.5	V

A.C. Programming Characteristics

$T_A = 25 \pm 5^\circ\text{C}$, $V_{CC} = 6.5 \pm 0.25\text{ V}$, $V_{PP} = 13.0 \pm 0.25\text{ V}$

Symbol	Parameter	Test Conditions* (see Note 1)	Limits		Units
			Min	Max	
t_{AS}	Address Setup Time		2		μs
t_{CES}	\overline{CE} Setup Time		2		μs
t_{OES}	\overline{OE} Setup Time		2		μs
t_{DS}	Data Setup Time		2		μs
t_{AH}	Address Hold Time		0		μs
t_{DH}	Data Hold Time		2		μs
t_{DFP}	\overline{OE} High to Output Float Delay	(Note 2)	0	130	ns
t_{VPS}	V_{PP} Setup Time		2		μs
t_{VCS}	V_{CC} Setup Time		2		μs
t_{PW}	PGM Program Pulse Width	(Note 3)	95	105	μs
t_{OE}	Data Valid from \overline{OE}			150	ns

*A.C. Conditions of Test:

Input Rise and Fall Times (10% to 90%) 5 ns
 Input Pulse Levels 0.0 V to 3.0 V
 Input Timing Reference Level 1.5 V
 Output Timing Reference Level 1.5 V

Notes:

- V_{CC} must be applied simultaneously or before V_{PP} and removed simultaneously or after V_{PP} .
- This parameter is only sampled and is not 100% tested. Output Float is defined as the point where data is no longer driven — see timing diagram.
- Program Pulse width tolerance is $100\ \mu\text{s} \pm 5\%$.

Atmel's 27HC1024 Integrated Product Identification Code

Codes	Pins								Hex Data		
	A0	015-08	O7	O6	O5	O4	O3	O2		O1	O0
Manufacturer	0	0	0	0	0	1	1	1	1	0	001E
Device Type	1	0	0	1	1	0	0	0	0	1	0061

Rapid Programming Algorithm

A $100\ \mu\text{s}$ PGM pulse width is used to program. The address is set to the first location. V_{CC} is raised to 6.5 V and V_{PP} is raised to 13.0 V. Each address is first programmed with one $100\ \mu\text{s}$ PGM pulse without verification. Then a verification / reprogramming loop is executed for each address. In the event a word fails to pass verification, up to 10 successive $100\ \mu\text{s}$ pulses are applied with a verification after each pulse. If the word fails to verify after 10 pulses have been applied, the part is considered failed. After the word verifies properly, the next address is selected until all have been checked. V_{PP} is then lowered to 5.0 V and V_{CC} to 5.0 V. All words are read again and compared with the original data to determine if the device passes or fails.

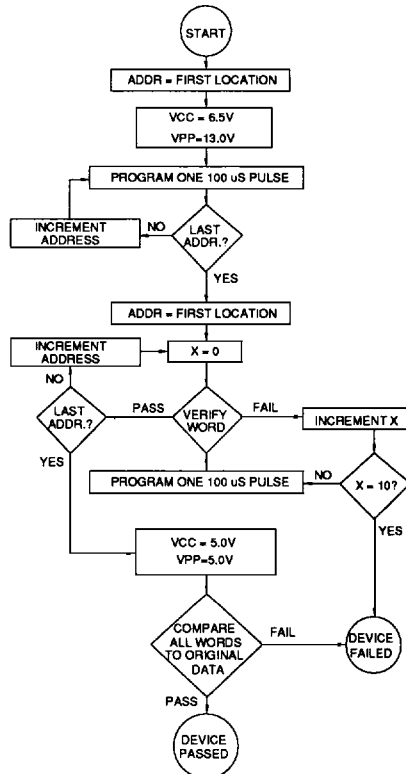



Ordering Information

t _{ACC} (ns)	I _{CC} (mA)		Ordering Code	Package	Operation Range
	Active	Standby			
55	80	8	AT27HC1024-55DC AT27HC1024-55JC AT27HC1024-55KC AT27HC1024-55LC AT27HC1024-55PC	40DW6 44J 44KW 44LW 40P6	Commercial (0°C to 70°C)
55	90	8	AT27HC1024-55DI AT27HC1024-55JI AT27HC1024-55LI	40DW6 44J 44LW	Industrial (-40°C to 85°C)
70	80	8	AT27HC1024-70DC AT27HC1024-70JC AT27HC1024-70KC AT27HC1024-70LC AT27HC1024-70PC	40DW6 44J 44KW 44LW 40P6	Commercial (0°C to 70°C)
70	90	10	AT27HC1024-70DI AT27HC1024-70JI AT27HC1024-70KI AT27HC1024-70LI AT27HC1024-70PI	40DW6 44J 44KW 44LW 40P6	Industrial (-40°C to 85°C)
			AT27HC1024-70DM AT27HC1024-70KM AT27HC1024-70LM	40DW6 44KW 44LW	Military (-55°C to 125°C)
			AT27HC1024-70DM/883 AT27HC1024-70KM/883 AT27HC1024-70LM/883	40DW6 44KW 44LW	Military/883C Class B, Fully Compliant (-55°C to 125°C)
90	80	8	AT27HC1024-90DC AT27HC1024-90JC AT27HC1024-90KC AT27HC1024-90LC AT27HC1024-90PC	40DW6 44J 44KW 44LW 40P6	Commercial (0°C to 70°C)
90	90	10	AT27HC1024-90DI AT27HC1024-90JI AT27HC1024-90KI AT27HC1024-90LI AT27HC1024-90PI	40DW6 44J 44KW 44LW 40P6	Industrial (-40°C to 85°C)
			AT27HC1024-90DM AT27HC1024-90KM AT27HC1024-90LM	40DW6 44KW 44LW	Military (-55°C to 125°C)
			AT27HC1024-90DM/883 AT27HC1024-90KM/883 AT27HC1024-90LM/883	40DW6 44KW 44LW	Military/883C Class B, Fully Compliant (-55°C to 125°C)
70	90	10	5962-86805 08 QX 5962-86805 08 XX	40DW6 44LW	Military/883C Class B, Fully Compliant (-55°C to 125°C)
90	90	10	5962-86805 07 QX 5962-86805 07 XX	40DW6 44LW	Military/883C Class B, Fully Compliant (-55°C to 125°C)

Ordering Information

Package Type	
40DW6	40 Lead, 0.600" Wide, Windowed, Ceramic Dual Inline Package (Cerdip)
44J	44 Lead, Plastic J-Leaded Chip Carrier OTP (PLCC)
44KW	44 Lead, Windowed, Ceramic J-Leaded Chip Carrier (JLCC)
44LW	44 Pad, Windowed, Ceramic Leadless Chip Carrier (LCC)
40P6	40 Lead, 0.600" Wide, Plastic Dual Inline Package OTP (PDIP)

