



Please note that Cypress is an Infineon Technologies Company.

The document following this cover page is marked as “Cypress” document as this is the company that originally developed the product. Please note that Infineon will continue to offer the product to new and existing customers as part of the Infineon product portfolio.

Continuity of document content

The fact that Infineon offers the following product as part of the Infineon product portfolio does not lead to any changes to this document. Future revisions will occur when appropriate, and any changes will be set out on the document history page.

Continuity of ordering part numbers

Infineon continues to support existing part numbers. Please continue to use the ordering part numbers listed in the datasheet for ordering.

EZ-USB® CX3: MIPI CSI-2 to SuperSpeed USB Bridge Controller

Features

- Universal Serial Bus (USB) integration
 - USB 3.0 and USB 2.0 peripherals, compliant with USB 3.0 specification 1.0
 - 5-Gbps USB 3.0 PHY compliant with PIPE 3.0
 - Thirty-two physical endpoints
- MIPI CSI-2 RX interface
 - MIPI CSI-2 compliant (Version 1.01, Revision 0.04 – 2nd April 2009)
 - Supports up to four data lanes (CYUSB3065 supports up to four lanes; CYUSB3064 supports up to two lanes)
 - Each lane supports up to 1 Gbps (CYUSB3065 supports up to four lanes; CYUSB3064 supports up to two lanes)
 - CCI interface for image sensor configuration
- Supports the following video data formats:
 - User-defined 8-bit
 - RAW8/10/12/14
 - YUV422 (CCIR/ITU 8/10bit), YUV444
 - RGB888/666/565
- Fully accessible 32-bit CPU
 - ARM926EJ-S core with 200-MHz operation
 - 512-KB or 256-KB embedded SRAM
- Additional connectivity to the following peripherals:
 - I²C master controller at 1 MHz
 - I²S master (transmitter only) at sampling frequencies of 8 kHz, 16 kHz, 32 kHz, 44.1 kHz, 48 kHz, 96 kHz, and 192 kHz
 - UART support of up to 4 Mbps
 - SPI master at 33 MHz
- Twelve GPIOs
- Ultra-low-power in core power-down mode
- Independent power domains for core and I/O
 - Core operation at 1.2 V
 - I²S, UART, and SPI operation at 1.8 to 3.3 V
 - I²C, I/O operation at 1.8 to 3.3 V
- 10 × 10 mm, 0.8-mm pitch Pb-free ball grid array (BGA) package
- EZ-USB® software development kit (SDK) for easy code development

Applications

- Digital video cameras
- Digital still cameras
- Webcams
- Scanners
- Video conference systems
- Gesture-based control
- Surveillance cameras
- Medical imaging devices
- Video IP phones
- USB microscopes
- Industrial cameras

Logic Block Diagram

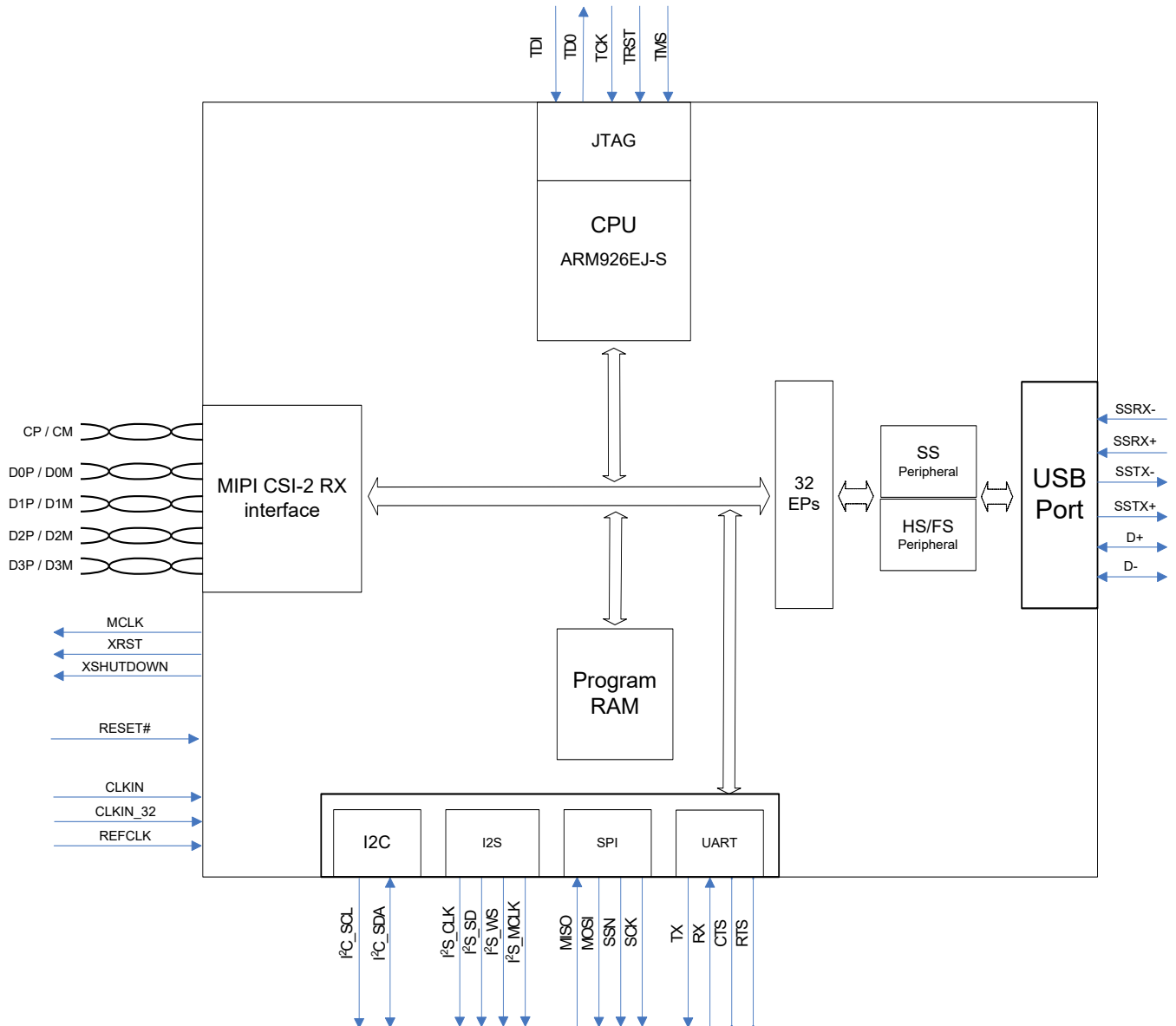

More Information

Cypress provides a wealth of data at www.cypress.com to help you to select the right device for your design, and to help you to quickly and effectively integrate the device into your design. For a comprehensive list of resources refer to the cypress web page for CX3 at www.cypress.com/CX3.

- Overview: [USB Portfolio](#), [USB Roadmap](#)
- USB 3.0 Product Selectors: [FX3](#), [FX3S](#), [CX3](#), [GX3](#), [HX3](#)
- Application notes: Cypress offers a large number of USB application notes covering a broad range of topics, from basic to advanced level. Recommended application notes for getting started with CX3 are:
 - [AN75705](#) - Getting Started with EZ-USB FX3
 - [AN90369](#) - How to Interface a MIPI CSI-2 Image Sensor With EZ-USB® CX3
 - [AN75779](#) - How to Implement an Image Sensor Interface with EZ-USB® FX3™ in a USB Video Class (UVC) Framework
 - [AN76405](#) - EZ-USB FX3 Boot Options
 - [AN70707](#) - EZ-USB FX3/FX3S Hardware Design Guidelines and Schematic Checklist
 - [AN86947](#) - Optimizing USB 3.0 Throughput with EZ-USB FX3
- Code Examples:
 - [USB SuperSpeed](#)
- Technical Reference Manual (TRM):
 - [EZ-USB® CX3 Technical Reference Manual](#)

- Knowledge Base Articles:
 - [CX3 Firmware: Frequently Asked Questions - KBA91297](#)
 - [CX3 Hardware: Frequently Asked Questions - KBA91295](#)
 - [CX3 Application Software / USB Driver: Frequently Asked Questions - KBA91298](#)
 - [Knowledge Base - Cypress Semiconductor Cage Code - KBA89258](#)
- Development Kits:
 - [Ascella - Cypress® CX3™ THine® ISP 13MP reference design kit \(RDK\)](#)
 - [Denebola - USB 3.0 UVC Reference Design Kit \(RDK\)](#)
 - [Tania - Cypress CX3™ Socionext® ISP reference design kit \(RDK\) with Dual Sony Sensors](#)
- Models:
 - [CX3 Device OrCad Schematic Symbol](#)
 - [CYUSB306x - IBIS](#)

EZ-USB Software Development Kit

Cypress delivers the complete firmware stack for CX3, in order to easily integrate SuperSpeed USB into any embedded MIPI image sensor application. The [Software Development Kit \(FX3 SDK\)](#) comes with tools, drivers and application examples, which help accelerate application development. The FX3 SDK Setup includes CX3 APIs and example firmware for OmniVision OV5640 and Aptina AS0260 image sensor interface. The [eclipse plugin](#) for the FX3 SDK accelerates CX3 firmware development for any other image sensor.

Contents

Functional Overview	5	Operating Conditions	17
Application Examples	5	DC Specifications	17
USB Interface	6	MIPI D-PHY Electrical Characteristics	19
ReNumeration	6	Thermal Characteristics	19
VBUS Overvoltage Protection	6	AC Timing Parameters	20
MIPI CSI-2 RX Interface	7	MIPI Data to Clock Timing Reference	20
Additional Outputs	7	Reference Clock Specifications	20
CPU	7	MIPI CSI Signal	
JTAG Interface	7	Low Power AC Characteristics	21
Other Interfaces	7	AC Specifications	21
UART Interface	7	Serial Peripherals Timing	22
I2C Interface	7	Reset Sequence	27
I2S Interface	8	Ordering Information	28
SPI Interface	8	Ordering Code Definitions	28
Boot Options	8	Package Diagram	29
Reset	8	Acronyms	30
Hard Reset	8	Document Conventions	30
Soft Reset	8	Units of Measure	30
Clocking	9	Errata	31
32-kHz Watchdog Timer Clock Input	9	Part Numbers Affected	31
Power	10	Qualification Status	31
Power Modes	10	Errata Summary	31
Configuration Options	13	Document History Page	37
Digital I/Os	13	Sales, Solutions, and Legal Information	40
GPIOs	13	Worldwide Sales and Design Support	40
EMI	13	Products	40
System-level ESD	13	PSoC® Solutions	40
Pin Configuration	14	Cypress Developer Community	40
Pin Description	15	Technical Support	40
Electrical Specifications	17		
Absolute Maximum Ratings	17		

Functional Overview

Cypress's EZ-USB CX3 is the next-generation bridge controller that can connect devices with the Mobile Industry Processor Interface – Camera Serial Interface 2 (MIPI CSI-2) interface to any USB 3.0 Host.

CX3 has a 4-lane CSI-2 receiver with up to 1 Gbps on each lane. It supports video data formats such as RAW8/10/12/14, YUV422 (CCIR/ITU 8/10-bit), RGB888/666/565, and user-defined 8-bit.

CX3 has integrated the USB 3.0 and USB 2.0 physical layers (PHYs) along with a 32-bit ARM926EJ-S microprocessor for powerful data processing and for building custom applications.

CX3 contains 512 KB of on-chip SRAM (see [Ordering Information on page 28](#)) for code and data. EZ-USB CX3 also provides interfaces to connect to serial peripherals such as UART, SPI, I²C, and I²S.

CX3 comes with application development tools. The software development kit comes with application examples for accelerating time-to-market.

CX3 complies with the USB 3.0 v1.0 specification and is also backward compatible with USB 2.0. It also complies with the MIPI CSI-2 v1.01, revision 0.04 specification dated 2nd April 2009.

Application Examples

In a typical application (see [Figure 1](#)), CX3 acts as the main processor and connects to an image sensor, an audio device, or camera control devices amongst others.

Figure 1. EZ-USB CX3 Example Application

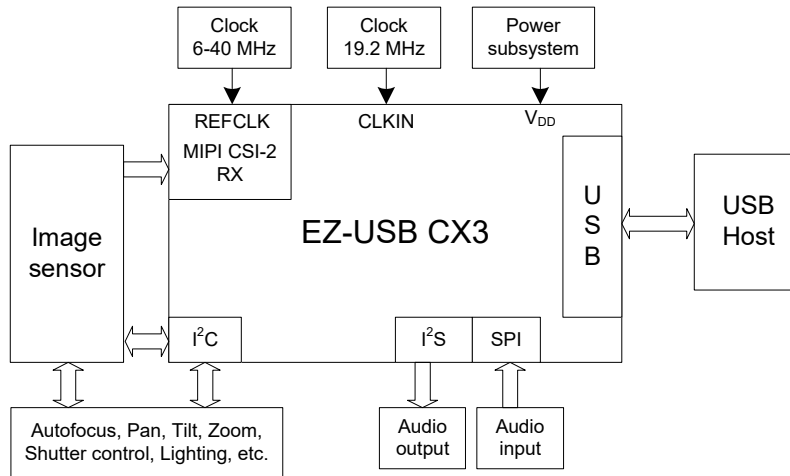

USB Interface

CX3 complies with the following specifications and supports the following features:

- Supports USB peripheral functionality compliant with USB 3.0 Specification, Revision 1.0, and is also backward compatible with the USB 2.0 Specification.
- As a peripheral, CX3 is capable of SuperSpeed, High-Speed, and Full-Speed.
- Supports up to 16 IN and 16 OUT endpoints
- Supports the USB 3.0 Streams feature
- As a USB peripheral, CX3 supports USB-attached storage (UAS), USB Video Class (UVC), and Media Transfer Protocol (MTP) USB peripheral classes. As a USB peripheral, all other device classes are supported only in pass-through mode when handled entirely by a host processor external to the device.

Figure 2. USB Interface Signals

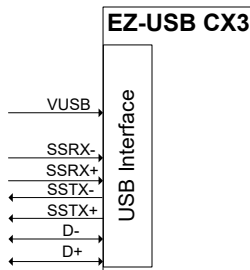

ReNumeration

Because of CX3's soft configuration, one chip can take on the identities of multiple distinct USB devices.

When first plugged into USB, CX3 enumerates automatically with the Cypress Vendor ID (0x04B4) and downloads the firmware and USB descriptors over the USB interface. The downloaded firmware executes an electrical disconnect and connect. CX3 enumerates again, this time as a device defined by the downloaded information. This patented two-step process, called ReNumeration, happens instantly when the device is plugged in.

VBUS Overvoltage Protection

The maximum input voltage on CX3's VUSB pin is 6 V. A charger can supply up to 9 V on VUSB. In this case, an external overvoltage protection (OVP) device is required to protect CX3 from damage on VUSB. Figure 3 shows the system application diagram with an OVP device connected on VUSB. Refer to DC Specifications on page 17 for the operating range of VUSB.

Note: The VBUS pin of the USB connector should be connected to the VUSB pin of CX3.

Figure 3. System Diagram with OVP Device For VUSB

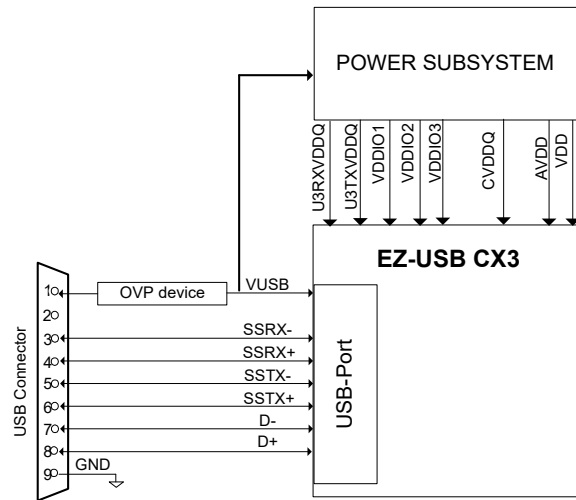

MIPI CSI-2 RX Interface

The Mobile Industry Processor Interface (MIPI) association defined the Camera Serial Interface 2 (CSI-2) standard to enable image data to be sent on high-bandwidth serial lines.

CX3 implements a MIPI CSI-2 Receiver with the following features:

1. It can receive clock and data in 1, 2, 3, or 4 lanes. (CY-USB3065 part supports up to four lanes; CYUSB3064 part supports up to two lanes)
2. Up to 1 Gbps of data on each CSI lane is supported (total maximum bandwidth should not exceed 2.4 Gbps).
3. Video formats such as RAW8/10/12/14, YUV422 (CCIR/ITU 8/10-bit), RGB888/666/565, and User-Defined 8-bit are supported
4. A CCI interface (compatible with 100-kHz or 400-kHz I²C interface with 7-bit addressing) is provided to configure the sensor.
5. GPIOs are available for synchronization of external flash or lighting system with image sensors to illuminate the scene that improves the image quality by improving Signal to noise ratio.
6. GPIOs can also be used to synchronize the image sensor with external events, so that image can be captured based on external event.
7. Serial interfaces (such as I²C, I²S, SPI, UART) are available to implement camera functions such as Auto focus and Pan, Tilt, Zoom (PTZ)

Additional Outputs

In addition to the standard MIPI CSI-2 signals, the following three additional outputs are provided:

1. Xrst: this can be used to reset the image sensor
2. XSHUTDOWN: this pin can be used to put the sensor to a standby/shutdown mode
3. MCLK: this pin can provide the clock output. It can be used only for testing the image sensor. For production, use an external clock generator as clock input for image sensors.

CPU

CX3 has an on-chip 32-bit, 200-MHz ARM926EJ-S core CPU. The core has direct access to 16 kB of Instruction Tightly Coupled Memory (TCM) and 8 kB of data TCM. The ARM926EJ-S core provides a JTAG interface for firmware debugging.

CX3 offers the following advantages:

- Integrates 512 KB of embedded SRAM for code and data and 8 kB of instruction cache and data cache.
- Implements efficient and flexible DMA connectivity between the various peripherals (such as, USB, CSI-2 Rx, I²S, SPI, and UART), requiring firmware only to configure data accesses between peripherals, which are then managed by the DMA fabric.
- Allows easy application development on industry-standard development tools for ARM926EJ-S.

Examples of the CX3 firmware are available with the Cypress EZ-USB CX3 Development Kit. Software APIs that can be ported to an external processor are available with the Cypress EZ-USB CX3 Software Development Kit.

JTAG Interface

CX3's JTAG interface has a standard five-pin interface to connect to a JTAG debugger in order to debug firmware through the CPU-core's on-chip-debug circuitry.

Industry-standard debugging tools for the ARM926EJ-S core can be used for the CX3 application development.

Other Interfaces

CX3 supports the following serial peripherals:

- UART
- I²C
- I²S
- SPI

The [CYUSB306X Pin List on page 15](#) shows the details of how these interfaces are mapped.

UART Interface

The UART interface of CX3 supports full-duplex communication. It includes the signals noted in [Table 1](#).

Table 1. UART Interface Signals

Signal	Description
TX	Output signal
RX	Input signal
CTS	Flow control
RTS	Flow control

The UART is capable of generating a range of baud rates, from 300 bps to 4608 Kbps, selectable by the firmware. If flow control is enabled, then CX3's UART only transmits data when the CTS input is asserted. In addition to this, CX3's UART asserts the RTS output signal, when it is ready to receive data.

I²C Interface

CX3's I²C interface is compatible with the I²C Bus Specification Revision 3. This I²C interface is capable of operating only as I²C master; therefore, it may be used to communicate with other I²C slave devices. For example, CX3 may boot from an EEPROM connected to the I²C interface, as a selectable boot option.

CX3's I²C Master Controller also supports multi-master mode functionality.

The power supply for the I²C interface is V_{DDIO1}, which is a separate power domain from the other serial peripherals. This gives the I²C interface the flexibility to operate at a different voltage than the other serial interfaces.

The I²C controller supports bus frequencies of 400 kHz, and 1 MHz. When V_{DDIO1} is 1.8 V, 2.5 V, or 3.3 V, the operating frequencies supported are 400 kHz and 1 MHz. The I²C

controller supports the clock-stretching feature to enable slower devices to exercise flow control.

The I²C interface's SCL and SDA signals require external pull-up resistors. The pull-up resistors must be connected to V_{DDIO1}.

Note: I²C addresses with the pattern 0x0000111x are used internally and no slave devices with those addresses should be connected to the bus.

I²S Interface

CX3 has an I²S port to support external audio codec devices. CX3 functions as I²S Master as transmitter only. The I²S interface consists of four signals: clock line (I2S_CLK), serial data line (I2S_SD), word select line (I2S_WS), and master system clock (I2S_MCLK). CX3 can generate the system clock as an output on I2S_MCLK or accept an external system clock input on I2S_MCLK.

The sampling frequencies supported by the I²S interface are 8 kHz, 16 kHz, 32 kHz, 44.1 kHz, 48 kHz, 96 kHz, and 192 kHz.

SPI Interface

CX3 supports an SPI Master interface on the Serial Peripherals port. The maximum operation frequency is 33 MHz.

The SPI controller supports four modes of SPI communication (see [SPI Timing Specification on page 25](#) for details on the modes) with the Start-Stop clock. This controller is a single-master controller with a single automated SSN control. It supports transaction sizes ranging from 4 bits to 32 bits.

Boot Options

CX3 can load boot images from various sources, selected by the configuration of the PMODE pins. Following are the CX3 boot options:

- Boot from USB
- Boot from I²C
- Boot from SPI
 - Cypress SPI flash parts supported are S25FS064S (64-Mbit), S25FS128S (128-Mbit) and S25LF064L (64-Mbit).
 - W25Q32FW (32-Mbit) is also supported.

Table 2. CX3 Booting Options

PMODE[2:0] ^[1]	Boot From
F11	USB boot
F1F	I ² C, On failure, USB boot is enabled
1FF	I ² C only
0F1	SPI, On failure, USB boot is enabled

Reset

Hard Reset

A hard reset is initiated by asserting the RESET# pin on CX3. The specific reset sequence and timing requirements are detailed in [Figure 11 on page 27](#) and [Table 18 on page 27](#). All I/Os are tristated during a hard reset.

An additional reset pin called MIPI_RESET is provided that resets the MIPI CSI-2 core. It should be pulled down with a resistor for normal operation.

Soft Reset

There are two types of Soft Reset:

- CPU Reset – The CPU Program Counter is reset. Firmware does not need to be reloaded following a CPU Reset.
- Whole Device Reset – This reset is identical to Hard Reset. The firmware must be reloaded following a Whole Device Reset.

Note

1. F indicates Floating.

Clocking

CX3 requires two clocks for normal operation:

1. A 19.2-MHz clock to be connected at the CLKIN pin
2. A 6-MHz to 40-MHz clock to be connected at the REFCLK pin

Clock inputs to CX3 must meet the phase noise and jitter requirements specified in [Table 3](#).

The input clock frequency is independent of the clock and data rate of the CX3 core or any of the device interfaces (including the

CSI-2 Rx Port). The internal PLL applies the appropriate clock-multiply option depending on the input frequency.

Note: REFCLK belongs to VDDIO1 power domain and CLKIN belongs to CVDDQ power domain. If same source is used, the clock must be passed through a buffer with two outputs and then connected to the clock pins. Make sure to power the clock buffer, CVDDQ and VDDIO1 with same voltage.

Table 3. CX3 Input Clock Specifications

Parameter	Description	Specification		Units
		Min	Max	
Phase noise	100-Hz offset	–	–75	dB
	1-kHz offset	–	–104	dB
	10-kHz offset	–	–120	dB
	100-kHz offset	–	–128	dB
	1-MHz offset	–	–130	dB
Maximum frequency deviation	–	–	150	ppm
Duty cycle	–	30	70	%
Overshoot	–	–	3	%
Undershoot	–	–	–3	%
Rise time/fall time	–	–	3	ns

32-kHz Watchdog Timer Clock Input

CX3 includes a watchdog timer. The watchdog timer can be used to interrupt the ARM926EJ-S core, automatically wake up the CX3 in Standby mode, and reset the ARM926EJ-S core. The watchdog timer runs a 32-kHz clock, which may be optionally supplied from an external source on a dedicated CX3 pin.

The firmware can disable the watchdog timer.

[Table 4](#) provides the requirements for the optional 32-kHz clock input

Table 4. 32-kHz Clock Input Requirements

Parameter	Min	Max	Units
Duty cycle	40	60	%
Frequency deviation	–	±200	ppm
Rise time/fall time	–	200	ns

Power

CX3 has the following power supply domains:

- **IO_VDDQ:** This is a group of independent supply domains for digital I/Os.
 - **V_{DDIO1}:** GPIO, I²C, JTAG, XRST, XSHUTDOWN and REF-CLK
 - **V_{DDIO2}:** UART and I²S (except MCLK)
 - **V_{DDIO3}:** I²S_MCLK and SPI
 - **C_{VDDQ}:** CLKIN
 - **V_{DD_MIPI}:** MIPI CSI-2 clock and data lanes
- **V_{DD}:** This is the supply voltage for the logic core. The nominal supply-voltage level is 1.2 V. This supplies the core logic circuits. The same supply must also be used for the following:
 - **A_{VDD}:** This is the 1.2 V supply for the PLL, crystal oscillator, and other core analog circuits.
 - **U3TXVDDQ/U3RXVDDQ:** These are the 1.2 V supply voltages for the USB 3.0 interface.
- **V_{USB}:** This is the 4 V to 6 V power supply for the USB I/O and analog circuits. This supply powers the USB transceiver through CX3's internal voltage regulator. V_{USB} is internally regulated to 3.3 V.

Note: The different power supplies have to be powered on or off in a specific sequence as illustrated in [Figure 4](#).

Power Modes

CX3 supports the following power modes:

- **Normal mode:** This is the full-functional operating mode. The internal CPU clock and the internal PLLs are enabled in this mode.
 - Normal operating power consumption does not exceed the sum of I_{CC} Core max and I_{CC} USB max (see [DC Specifications on page 17](#) for current consumption specifications).
 - The I/O power supplies V_{DDIO2} and V_{DDIO3} can be turned off when the corresponding interface is not in use. V_{DDIO1} should never be turned off for normal operation.
- **Low-power modes** (see [Table 5 on page 11](#)):
 - Suspend mode with USB 3.0 PHY enabled
 - Standby mode
 - Core power-down mode

Figure 4. Power-up Sequence

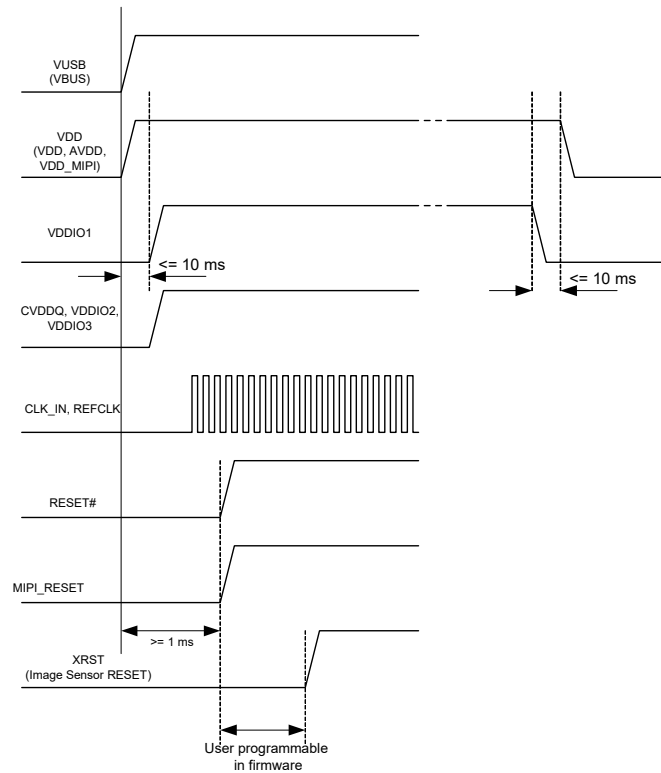

Table 5. Entry and Exit Methods for Low-Power Modes

Low-Power Mode	Characteristics	Methods of Entry	Methods of Exit
Suspend Mode with USB 3.0 PHY Enabled	<ul style="list-style-type: none"> ■ Power consumption in this mode does not exceed I_{SB1} ■ USB 3.0 PHY is enabled and is in U3 mode (one of the suspend modes defined by the USB 3.0 specification). This one block alone is operational with its internal clock, while all other clocks are shut down ■ All I/Os maintain their previous state ■ Power supply for the wakeup source and core power must be retained. All other power domains can be turned on or off individually ■ The states of the configuration registers, buffer memory, and all internal RAM are maintained ■ All transactions must be completed before CX3 enters suspend mode (state of outstanding transactions are not preserved) ■ The firmware resumes operation from where it was suspended (except when woken up by RESET# assertion) because the program counter does not reset 	<ul style="list-style-type: none"> ■ Firmware executing on ARM926EJ-S core can put CX3 into the suspend mode. For example, on USB suspend condition, the firmware may decide to put CX3 into suspend mode 	<ul style="list-style-type: none"> ■ D+ transitioning to low or high ■ D- transitioning to low or high ■ Resume condition on SSRX± ■ Detection of VBUS ■ Level detect on UART_CTS (programmable polarity) ■ Assertion of RESET#
Standby Mode	<ul style="list-style-type: none"> ■ The power consumption in this mode does not exceed I_{SB3} ■ All configuration register settings and program/data RAM contents are preserved. However, data in the buffers or other parts of the data path, if any, is not guaranteed. Therefore, the external processor should take care that the data needed is read before putting CX3 into the standby mode ■ The program counter is reset after waking up from the standby mode ■ GPIO pins maintain their configuration ■ Internal PLL is turned off ■ USB transceiver is turned off ■ ARM926EJ-S core is powered down. Upon wakeup, the core re-starts and runs the program stored in the program/data RAM ■ Power supply for the wakeup source and core power must be retained. All other power domains can be turned on or off individually 	<ul style="list-style-type: none"> ■ The firmware executing on ARM926EJ-S core or external processor configures the appropriate register 	<ul style="list-style-type: none"> ■ Detection of VBUS ■ Level detect on UART_CTS (programmable polarity) ■ Assertion of RESET#

Table 5. Entry and Exit Methods for Low-Power Modes (continued)

Low-Power Mode	Characteristics	Methods of Entry	Methods of Exit
Core Power-down Mode	<ul style="list-style-type: none"> ■ The power consumption in this mode does not exceed ISB_4 ■ Core power is turned off ■ All buffer memory, configuration registers, and the program RAM do not maintain state. After exiting this mode, reload the firmware ■ In this mode, all other power domains can be turned on or off individually 	<ul style="list-style-type: none"> ■ Turn off V_{DD} 	<ul style="list-style-type: none"> ■ Reapply V_{DD} ■ Assertion of RESET#

Configuration Options

Configuration options are available for specific usage models. Contact Cypress Marketing (usb3@cypress.com) for details.

Digital I/Os

CX3 has internal firmware-controlled pull-up or pull-down resistors on all digital I/O pins. An internal 50-k Ω resistor pulls the pins high, while an internal 10-k Ω resistor pulls the pins low to prevent them from floating. The I/O pins may have the following states:

- Tristated (High-Z)
- Weak pull-up (via internal 50 k Ω)
- Pull-down (via internal 10 k Ω)
- Hold (I/O hold its value) when in low-power modes
- The JTAG TDI, TMC, and TRST# signals have fixed 50-k Ω internal pull-ups, and the TCK signal has a fixed 10-k Ω pull-down resistor.

All unused I/Os should be pulled high by using the internal pull-up resistors. All unused outputs should be left floating. All I/Os can be driven at full-strength, three-quarter strength, half-strength, or quarter-strength. These drive strengths are configured separately for each interface.

GPIOs

CX3 provides 12 pins for general purpose I/O (for example, can be used for lighting, sync-in, sync-out and so on). See [Pin Configuration on page 14](#) for pinout details.

All GPIO pins support an external load of up to 16 pF for every pin.

EMI

CX3 can meet EMI requirements outlined by FCC 15B (USA) and EN55022 (Europe) for consumer electronics at system level. CX3 can tolerate reasonable EMI, conducted by the aggressor, outlined by these specifications and continue to function as expected.

System-level ESD

CX3 has built-in ESD protection on the D+, D-, and GND pins on the USB interface. The ESD protection levels provided on these ports are:

- ± 2.2 -kV human body model (HBM) based on JESD22-A114 specification
- ± 6 -kV contact discharge and ± 8 -kV air gap discharge based on IEC61000-4-2 level 3A using external system-level protection devices
- ± 8 -kV contact discharge and ± 15 -kV air gap discharge based on IEC61000-4-2 level 4C using external system-level protection devices

This protection ensures that the device continues to function after ESD events up to the levels stated in this section.

The SSRX+, SSRX-, SSTX+, and SSTX- pins only have up to ± 2.2 -kV HBM internal ESD protection.

Pin Configuration



Figure 5. CX3 Ball Map (Top View)

A1	A2	A3	A4	A5	A6	A7	A8	A9	A10	A11
U3VSSQ	U3RXVDDQ	SSRXM	SSRXP	SSTXP	SSTXM	AVDD	VSS	DP	DM	GPIO[24]
B1	B2	B3	B4	B5	B6	B7	B8	B9	B10	B11
VDDIO3	VSS	GPIO[23]	GPIO[21]	U3TXVDDQ	CVDDQ	AVSS	VSS	VSS	VDD	TRST#
C1	C2	C3	C4	C5	C6	C7	C8	C9	C10	C11
SPI_SSN / GPIO[54]	SPI_MISO / GPIO[55]	VDD	GPIO[26]	RESET#	GPIO[18]	GPIO[19]	GPIO[22]	GPIO[45]	TDO	I2S_MCLK / GPIO[57]
D1	D2	D3	D4	D5	D6	D7	D8	D9	D10	D11
I2S_CLK / GPIO[50]	I2S_SD / GPIO[51]	I2S_WS / GPIO[52]	SPI_SCK / GPIO[53]	SPI_MOSI / GPIO[56]	CLKIN_32	CLKIN	VSS	I2C_SCL	I2C_SDA	GPIO[17]
E1	E2	E3	E4	E5	E6	E7	E8	E9	E10	E11
UART_CTS / GPIO[47]	VSS	VDDIO2	UART_RX / GPIO[49]	UART_TX / GPIO[48]	GPIO[20]	TDI	TMS	VDD	VUSB	VSS
F1	F2	F3	F4	F5	F6	F7	F8	F9	F10	F11
DNU	REFCLK	GPIO[44]	XRST	UART_RTS / GPIO[46]	TCK	DNU	DNU	DNU	DNU	VDD
G1	G2	G3	G4	G5	G6	G7	G8	G9	G10	G11
VSS	XSHUTDOWN	MCLK	PMODE[0] / GPIO[30]	GPIO[25]	HSYNC_test	DNU	DNU	DNU	DNU	VSS
H1	H2	H3	H4	H5	H6	H7	H8	H9	H10	H11
VDD	DNU	DNU	PMODE[1] / GPIO[31]	VSYNC_test	MIPI RESET	DNU	PCLK_test	DNU	DNU	VDDIO1
J1	J2	J3	J4	J5	J6	J7	J8	J9	J10	J11
DNU	DNU	DNU	DNU	MIPI_D0P	MIPI_D1P ¹	MIPI_CP	MIPI_D2P ^{1,2}	MIPI_D2N ^{1,2}	DNU	VDD
K1	K2	K3	K4	K5	K6	K7	K8	K9	K10	K11
DNU	DNU	VSS	VSS	MIPI_D0N	MIPI_D1N ¹	MIPI_CN	MIPI_D3N ^{1,2}	DNU	DNU	DNU
L1	L2	L3	L4	L5	L6	L7	L8	L9	L10	L11
VSS	VSS	VSS	PMODE[2] / GPIO[32]	VDD_MIPI	VSS	VDD	MIPI_D3P ^{1,2}	VDDIO1	DNU	VSS

1. Unused MIPI input data lanes to be connected to GND.

2. The signals MIPI_D2N, MIPI_D2P, MIPI_D3N, and MIPI_D3P are not available in the CYUSB3064 part. These pins should be left "open" in the customer board.

Legend

	Ground
	USB PHY power supply; Clock power supply
	Power supply

Pin Description
Table 6. CYUSB306X Pin List

CX3		
Pin#	Pin name	I/O
F10	DNU	I/O
F9	DNU	I/O
F7	DNU	I/O
G10	DNU	I/O
G9	DNU	I/O
F8	DNU	I/O
H10	DNU	I/O
H9	DNU	I/O
J10	DNU	I/O
H7	DNU	I/O
K11	DNU	I/O
L10	DNU	I/O
K10	DNU	I/O
K9	DNU	I/O
G7	DNU	I/O
G8	DNU	I/O
K2	DNU	I/O
J4	DNU	I/O
K1	DNU	I/O
J2	DNU	I/O
J3	DNU	I/O
J1	DNU	I/O
H2	DNU	I/O
H3	DNU	I/O
G6	HSYNC_test	I/O
H5	VSYNC_test	I/O
H8	PCLK_test	I/O
VDDIO1 Power Domain		
D11	GPIO[17]	I/O
C6	GPIO[18]	I/O
C7	GPIO[19]	I/O
E6	GPIO[20]	I/O
B4	GPIO[21]	I/O
C8	GPIO[22]	I/O
B3	GPIO[23]	I/O
A11	GPIO[24]	I/O
G5	GPIO[25]	I/O

Table 6. CYUSB306X Pin List (continued)

CX3		
Pin#	Pin name	I/O
C4	GPIO[26]	I/O
F3	GPIO[44]	I/O
C9	GPIO[45]	I/O
G4	PMODE[0] / GPIO[30]	I/O
H4	PMODE[1] / GPIO[31]	I/O
L4	PMODE[2] / GPIO[32]	I/O
F1	DNU	I/O
H6	MIPI RESET	I/O
C5	RESET#	I
F4	XRST	O
G2	XSHUTDOWN	O
G3	MCLK	O
VDDIO2 Power Domain		
F5	UART_RTS / GPIO[46]	I/O
E1	UART_CTS / GPIO[47]	I/O
E5	UART_TX / GPIO[48]	I/O
E4	UART_RX / GPIO[49]	I/O
D1	I2S_CLK / GPIO[50]	I/O
D2	I2S_SD / GPIO[51]	I/O
D3	I2S_WS / GPIO[52]	I/O
VDDIO3 Power Domain		
D4	SPI_SCK / GPIO[53]	I/O
C1	SPI_SSN / GPIO[54]	I/O
C2	SPI_MISO / GPIO[55]	I/O
D5	SPI_MOSI / GPIO[56]	I/O
C11	I2S_MCLK / GPIO[57]	I/O
USB Port (U3TXVDDQ/U3RXVDDQ Power Domain)		
A3	SSRXM	I
A4	SSRXP	I
A6	SSTXM	O
A5	SSTXP	O
USB Port (VUSB Power Domain)		
A9	DP	I/O
A10	DM	I/O
VDDIO1 Power Domain		
F2	REFCLK	I
VDD_MIPI Power Domain		
J7	MIPI_CP	I

Table 6. CYUSB306X Pin List (continued)

CX3		
Pin#	Pin name	I/O
K7	MIPI_CN	I
J5	MIPI_D0P	I
K5	MIPI_D0N	I
J6	MIPI_D1P ¹	I
K6	MIPI_D1N ¹	I
J9	MIPI_D2N ^{1, 2}	I
J8	MIPI_D2P ^{1, 2}	I
L8	MIPI_D3P ^{1, 2}	I
K8	MIPI_D3N ^{1, 2}	I
CVDDQ Power Domain		
D7	CLKIN	I
D6	CLKIN_32	I
VDDIO1 Power Domain		
D9	I2C_SCL	I/O
D10	I2C_SDA	I/O
E7	TDI	I
C10	TDO	O
B11	TRST#	I
E8	TMS	I
F6	TCK	I
Power Domains		
E10	VUSB	PWR
A1	U3VSSQ	PWR
H11	VDDIO1	PWR
L9	VDDIO1	PWR
E3	VDDIO2	PWR
B1	VDDIO3	PWR
B6	CVDDQ	PWR
B5	U3TXVDDQ	PWR
A2	U3RXVDDQ	PWR
A7	AVDD	PWR
B7	AVSS	PWR
L5	VDD_MIPI	PWR
B10	VDD	PWR
J11	VDD	PWR
C3	VDD	PWR
E9	VDD	PWR
F11	VDD	PWR
H1	VDD	PWR

Table 6. CYUSB306X Pin List (continued)

CX3		
Pin#	Pin name	I/O
L7	VDD	PWR
D8	VSS	PWR
E2	VSS	PWR
E11	VSS	PWR
G1	VSS	PWR
A8	VSS	PWR
G11	VSS	PWR
L1	VSS	PWR
B8	VSS	PWR
L6	VSS	PWR
B2	VSS	PWR
L11	VSS	PWR
B9	VSS	PWR
K4	VSS	PWR
L3	VSS	PWR
K3	VSS	PWR
L2	VSS	PWR

1. Unused MIPI input data lanes to be connected to GND.
2. The signals MIPI_D2N, MIPI_D2P, MIPI_D3N, and MIPI_D3P are not available in the CYUSB3064 part. These pins should be left "open" in the customer board.

Electrical Specifications

Absolute Maximum Ratings

Exceeding maximum ratings may shorten the useful life of the device.

Storage temperature	-65 °C to +150 °C
Supply voltage to ground potential V_{DD} , A_{VDDQ}	1.25 V
V_{DDIO1} , V_{DDIO2} , V_{DDIO3}	3.6 V
$U3TX_{VDDQ}$, $U3RX_{VDDQ}$	1.25 V
DC input voltage to any input pin	$V_{CC} + 0.3$
DC voltage applied to outputs in high Z state (V_{CC} is the corresponding I/O voltage)	$V_{CC} + 0.3$

DC Specifications

Table 7. DC Specifications

Parameter	Description	Min	Max	Units	Notes
V_{DD}	Core voltage supply	1.15	1.25	V	1.2-V typical
A_{VDD}	Analog voltage supply	1.15	1.25	V	1.2-V typical
V_{DD_MIPI}	MIPI bridge D-PHY supply voltage	1.15	1.25	V	1.2-V typical
V_{DDIO1}	I ² C, JTAG and GPIO power domain	1.7	3.6	V	1.8-, 2.5-, and 3.3-V typical
V_{DDIO2}	UART/I ² S power supply domain	1.7	3.6	V	1.8-, 2.5-, and 3.3-V typical
V_{DDIO3}	SPI/I ² S power supply domain	1.7	3.6	V	1.8-, 2.5-, and 3.3-V typical
V_{USB}	USB voltage supply	4	6	V	5-V typical
$U3TX_{VDDQ}$	USB 3.0 1.2-V supply	1.15	1.25	V	1.2-V typical. A 22- μ F bypass capacitor is required on this power supply.
$U3RX_{VDDQ}$	USB 3.0 1.2-V supply	1.15	1.25	V	1.2-V typical. A 22- μ F bypass capacitor is required on this power supply.
C_{VDDQ}	Clock voltage supply	1.7	3.6	V	1.8-, 3.3-V typical
V_{IH1}	Input HIGH voltage 1	$0.625 \times V_{CC}$	$V_{CC} + 0.3$	V	For $2.0 \text{ V} \leq V_{CC} \leq 3.6 \text{ V}$ (except USB and MIPI CSI-2 pins). V_{CC} is the corresponding I/O voltage supply.
V_{IH2}	Input HIGH voltage 2	$V_{CC} - 0.4$	$V_{CC} + 0.3$	V	For $1.7 \text{ V} \leq V_{CC} \leq 2.0 \text{ V}$ (except USB USB and MIPI CSI-2 pins). V_{CC} is the corresponding I/O voltage supply.
V_{IL}	Input LOW voltage	-0.3	$0.25 \times V_{CC}$	V	V_{CC} is the corresponding I/O voltage supply.
V_{OH}	Output HIGH voltage	$0.9 \times V_{CC}$	-	V	$I_{OH}(\text{max}) = -100 \mu\text{A}$ tested at quarter drive strength. V_{CC} is the corresponding I/O voltage supply. Refer to Table 8 on page 18 for values of I_{OH} at various drive strength and V_{CC} .
V_{OL}	Output LOW voltage	-	$0.1 \times V_{CC}$	V	$I_{OL}(\text{min}) = +100 \mu\text{A}$ tested at quarter drive strength. V_{CC} is the corresponding I/O voltage supply. Refer to Table 8 on page 18 for values of I_{OL} at various drive strength and V_{CC} .

Maximum latch-up current 140 mA

Maximum output short-circuit current for all I/O configurations. ($V_{OUT} = 0 \text{ V}$) -100 mA

Operating Conditions

T_A (ambient temperature under bias)	
Commercial	0 °C to +70 °C
Industrial	-40 °C to +85 °C
V_{DD} , A_{VDDQ} , $U3TX_{VDDQ}$, $U3RX_{VDDQ}$	
Supply voltage	1.15 V to 1.25 V
V_{USB} supply voltage	4 V to 6 V
V_{DDIO1} , V_{DDIO2} , V_{DDIO3} , C_{VDDQ}	
Supply voltage	1.7 V to 3.6 V

Table 7. DC Specifications (continued)

Parameter	Description	Min	Max	Units	Notes
I_{IX}	Input leakage current for all pins except SSTXP/SSXM/SSRXP/SSRXM	-1	1	μA	All I/O signals held at V_{DDQ} (For I/Os with a pull-up or pull-down resistor connected, the leakage current increases by V_{DDQ}/R_{PU} or V_{DDQ}/R_{PD})
I_{OZ}	Output High-Z leakage current for all pins except SSTXP/SSXM/SSRXP/SSRXM and MIPI CSI-2 signals	-1	1	μA	All I/O signals held at V_{DDQ}
I_{CC} Core	Core and analog voltage operating current	-	192	mA	Total current through A_{VDD} , V_{DD}
I_{CC} USB	USB voltage supply operating current	-	60	mA	-
I_{SB1}	Total suspend current during suspend mode with USB 3.0 PHY enabled	Core: 558.35 μA	-	μA	Core Current is measured through V_{DD} , A_{VDD} and V_{DD_MIPI} .
		I/O: 4.58 μA	-	μA	
		USB: 4672 μA	-	μA	I/O Current is measured through V_{DDIO1} to V_{DDIO3} .
I_{SB3}	Total standby current during core power-down mode	Core: 148.31 μA	-	μA	USB Current is measured through V_{USB} , $U3TX_{VDDQ}$ and $U3RX_{VDDQ}$.
		I/O: 3.16 μA	-	μA	
		USB: 15.8 μA	-	μA	
V_{RAMP}	Voltage ramp rate on core and I/O supplies	0.2	12	V/ms	Voltage ramp must be monotonic
V_N	Noise level permitted on V_{DD} and I/O supplies	-	100	mV	Max p-p noise level permitted on all supplies except A_{VDD}
V_N_{AVDD}	Noise level permitted on A_{VDD} supply	-	20	mV	Max p-p noise level permitted on A_{VDD}

Table 8. I_{OH}/I_{OL} values for different drive strength and V_{DDIO} values

V_{DDIO} (V)	V_{OH} (V)	V_{OL} (V)	Drive Strength	$I_{OH\ max}$ (mA)	$I_{OL\ min}$ (mA)
1.7	1.53	0.17	Quarter	1.02	2.21
			Half	1.51	3.28
			Three-Quarters	1.83	3.85
			Full	2.28	4.73
2.5	2.25	0.25	Quarter	5.03	3.96
			Half	7.38	5.84
			Three-Quarters	8.89	6.89
			Full	11.07	8.61
3.6	3.24	0.36	Quarter	7.80	5.74
			Half	11.36	8.64
			Three-Quarters	13.64	10.15
			Full	16.92	12.67

MIPI D-PHY Electrical Characteristics
Table 9. MIPI D-PHY Electrical Characteristics

Parameter	Description	Spec			Unit
		Min	Nom	Max	
MIPI D-PHY RX DC Characteristics					
V _{PIN}	Pin signal voltage range	-50	-	1350	mV
V _{IH}	Logic 1 input voltage	880	-	-	mV
V _{IL}	Logic 0 input voltage	-	-	550	mV
V _{CMRX (DC)}	Common-mode voltage HS receiver mode	70	-	330	mV
V _{IDTH}	Differential input high threshold		-	70	mV
V _{IDTL}	Differential input low threshold	-70	-	-	mV
V _{IHHS}	Single-ended input high voltage		-	460	mV
V _{ILHS}	Single-ended input low voltage	-40	-	-	mV

Thermal Characteristics
Table 10. Thermal Characteristics

Parameter	Description	Value	Unit
T _{J MAX}	Maximum Junction Temperature	125	°C
Θ _{JA}	Thermal resistance (junction to ambient)	24.4	°C/W
Θ _{JB}	Thermal resistance (junction to board)	17.27	°C/W
Θ _{JC}	Thermal resistance (junction to case)	5.5	°C/W

AC Timing Parameters

MIPI Data to Clock Timing Reference

Figure 6. MIPI CSI Signal Data to Clock Timing Reference

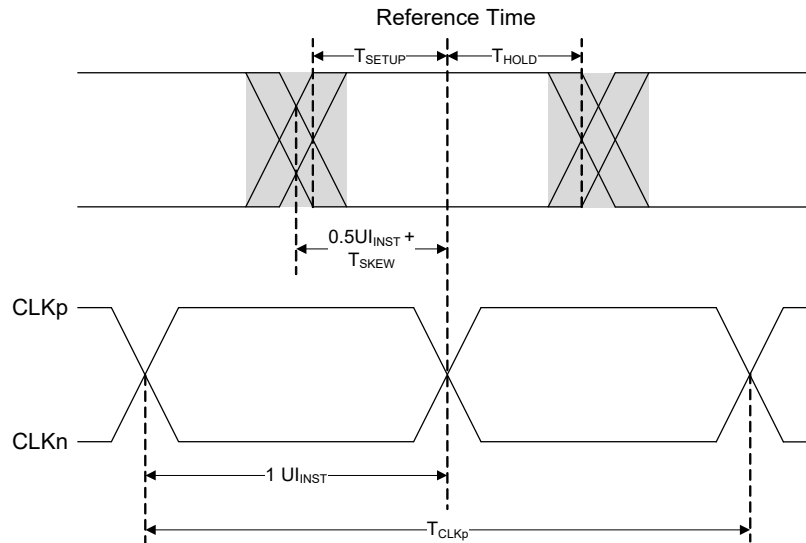

Table 11. MIPI Data to Clock Timing Reference

Parameter	Description	Min	Max	Units
T_{SKEW}	Data to clock skew measured at the transmitter	-0.15	0.15	U_{INST}
T_{SETUP}	Data to clock setup time at receiver	0.15	-	U_{INST}
T_{HOLD}	Clock to data hold time at receiver	0.15	-	U_{INST}
U_{INST}	One data bit time (instantaneous)	1	12.5	ns
T_{CLKp}	Period of dual data rate clock	2	25	ns

Reference Clock Specifications

Table 12. Reference Clock Specifications

Parameter	Description	Min	Max	Units	Notes
RefClk	Reference clock frequency	6	40	MHz	-
RefclkDutyCyl	Duty cycle	40%	60%	-	-
RefClkPJ	Reference clock input period jitter	-100	100	ps	-

MIPI CSI Signal Low Power AC Characteristics

Figure 7. MIPI CSI bus Input Glitch Rejection

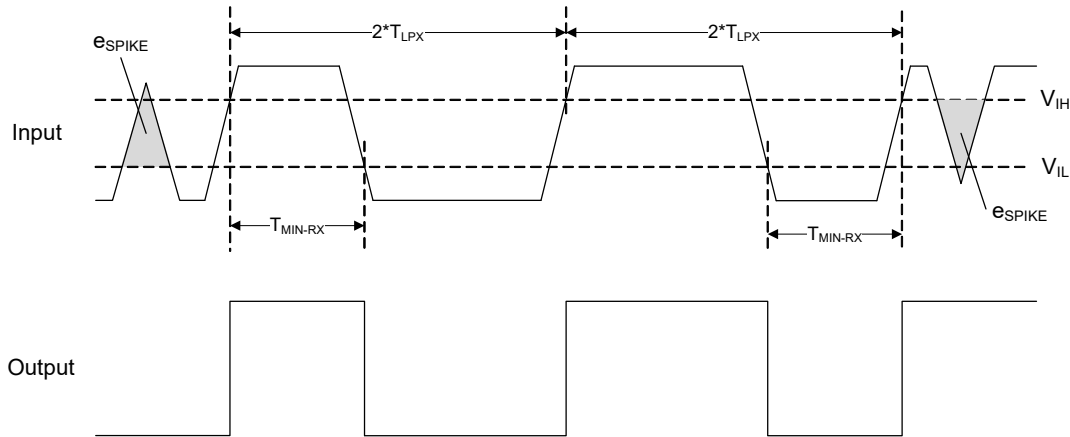

Table 13. MIPI CSI Signal Low Power AC Characteristics

Parameter	Description	Min	Max	Units	Notes
e_{SPIKE}	Input noise rejection	–	300	V.ps	Time-voltage integration of a spike above V_{IL} when being in LP-0 or below V_{IH} when being in LP-1 state. An impulse less than this will not change the receiver state.
T_{MIN-RX}	Minimum pulse width response	20	–	ns	An input pulse greater than this shall toggle the output.
V_{INT}	peak interference amplitude	–	200	mV	–
F_{INT}	Interference frequency	450	–	MHz	–
T_{LPX}	Length of any low power state period	50	–	ns	–

AC Specifications

Table 14. AC Specifications

Parameter	Description	Min	Max	Units	Details / Conditions
$\Delta V_{CMRX(HF)}$	Common-mode interference beyond 450 MHz	–	100	mV	$\Delta V_{CMRX(HF)}$ is the peak amp. Of a sine wave superimposed on the receiver inputs.
$\Delta V_{CMRX(LF)}$	Common-mode interference beyond 50 - 450 MHz	-50	50	mV	Excluding static ground shift of 50 mV. Voltage difference compared to the DC average common-mode potential

Serial Peripherals Timing

I²C Timing

Figure 8. I²C Timing Definition

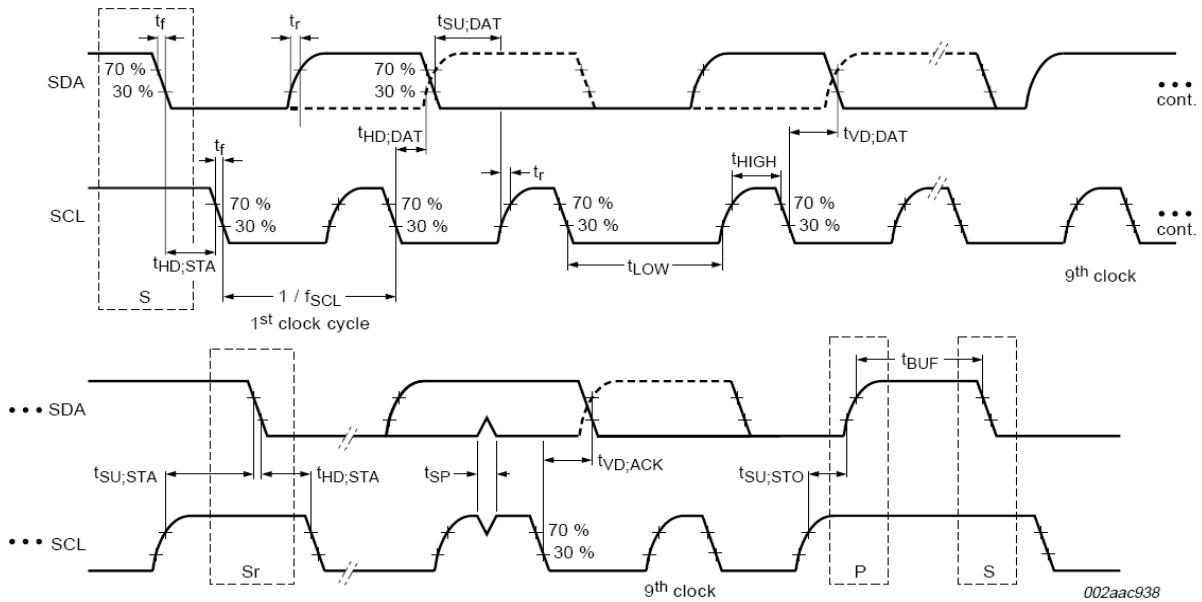

Table 15. I²C Timing Parameters^[2]

Parameter	Description	Min	Max	Units
I²C Standard Mode Parameters				
f_{SCL}	SCL clock frequency	0	100	kHz
$t_{HD:STA}$	Hold time START condition	4	–	μ s
t_{LOW}	LOW period of the SCL	4.7	–	μ s
t_{HIGH}	HIGH period of the SCL	4	–	μ s
$t_{SU:STA}$	Setup time for a repeated START condition	4.7	–	μ s
$t_{HD:DAT}$	Data hold time	0	–	μ s
$t_{SU:DAT}$	Data setup time	250	–	ns
t_r	Rise time of both SDA and SCL signals	–	1000	ns
t_f	Fall time of both SDA and SCL signals	–	300	ns
$t_{SU:STO}$	Setup time for STOP condition	4	–	μ s
t_{BUF}	Bus free time between a STOP and START condition	4.7	–	μ s
$t_{VD:DAT}$	Data valid time	–	3.45	μ s
$t_{VD:ACK}$	Data valid ACK	–	3.45	μ s
t_{SP}	Pulse width of spikes that must be suppressed by input filter	n/a	n/a	

Note

2. All parameters guaranteed by design and validated through characterization.

Table 15. I²C Timing Parameters^[2] (continued)

Parameter	Description	Min	Max	Units
I²C Fast Mode Parameters				
f _{SCL}	SCL clock frequency	0	400	kHz
t _{HD:STA}	Hold time START condition	0.6	–	μs
t _{LOW}	LOW period of the SCL	1.3	–	μs
t _{HIGH}	HIGH period of the SCL	0.6	–	μs
t _{SU:STA}	Setup time for a repeated START condition	0.6	–	μs
t _{HD:DAT}	Data hold time	0	–	μs
t _{SU:DAT}	Data setup time	100	–	ns
t _r	Rise time of both SDA and SCL signals	–	300	ns
t _f	Fall time of both SDA and SCL signals	–	300	ns
t _{SU:STO}	Setup time for STOP condition	0.6	–	μs
t _{BUF}	Bus free time between a STOP and START condition	1.3	–	μs
t _{VD:DAT}	Data valid time	–	0.9	μs
t _{VD:ACK}	Data valid ACK	–	0.9	μs
t _{SP}	Pulse width of spikes that must be suppressed by input filter	0	50	ns
I²C Fast Mode Plus Parameters				
f _{SCL}	SCL clock frequency	0	1000	kHz
t _{HD:STA}	Hold time START condition	0.26	–	μs
t _{LOW}	LOW period of the SCL	0.5	–	μs
t _{HIGH}	HIGH period of the SCL	0.26	–	μs
t _{SU:STA}	Setup time for a repeated START condition	0.26	–	μs
t _{HD:DAT}	Data hold time	0	–	μs
t _{SU:DAT}	Data setup time	50	–	ns
t _r	Rise time of both SDA and SCL signals	–	120	ns
t _f	Fall time of both SDA and SCL signals	–	120	ns
t _{SU:STO}	Setup time for STOP condition	0.26	–	μs
t _{BUF}	Bus-free time between a STOP and START condition	0.5	–	μs
t _{VD:DAT}	Data valid time	–	0.45	μs
t _{VD:ACK}	Data valid ACK	–	0.55	μs
t _{SP}	Pulse width of spikes that must be suppressed by input filter	0	50	ns

I²S Timing Diagram

Figure 9. I²S Transmit Cycle

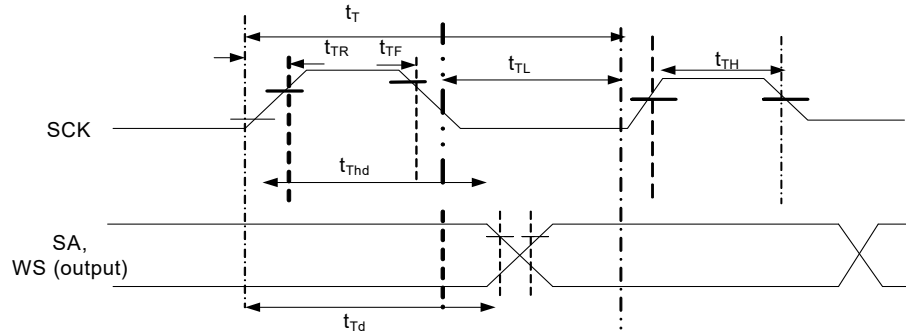

Table 16. I²S Timing Parameters^[3]

Parameter	Description	Min	Max	Units
t_T	I ² S transmitter clock cycle	t_{TR}	–	ns
t_{TL}	I ² S transmitter cycle LOW period	$0.35 t_{TR}$	–	ns
t_{TH}	I ² S transmitter cycle HIGH period	$0.35 t_{TR}$	–	ns
t_{TR}	I ² S transmitter rise time	–	$0.15 t_{TR}$	ns
t_{TF}	I ² S transmitter fall time	–	$0.15 t_{TR}$	ns
t_{Thd}	I ² S transmitter data hold time	0	–	ns
t_{Td}	I ² S transmitter delay time	–	$0.8 t_T$	ns

Note t_T is selectable through clock gears. Max t_{TR} is designed for 96-kHz codec at 32 bits to be 326 ns (3.072 MHz).

Note

3. All parameters guaranteed by design and validated through characterization.

SPI Timing Specification

Figure 10. SPI Timing

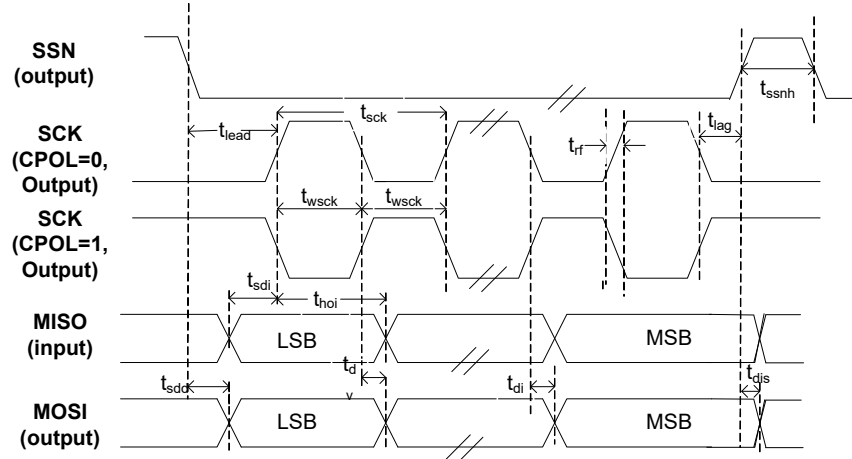

SPI Master Timing for CPHA = 0

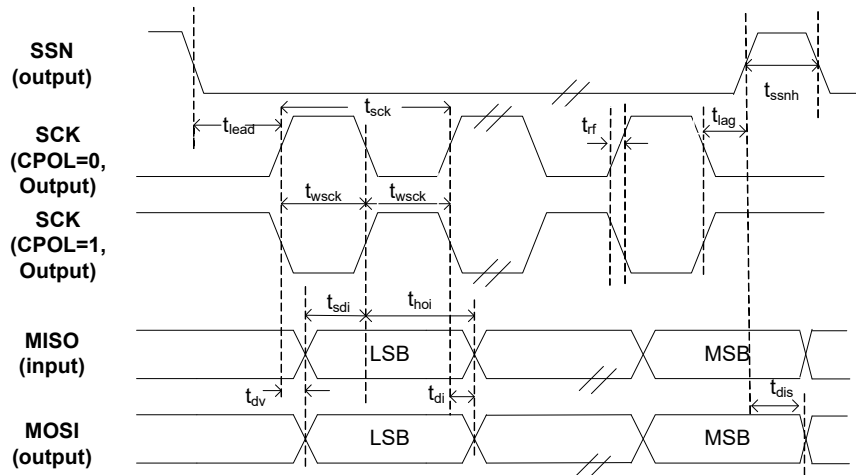

SPI Master Timing for CPHA = 1

Table 17. SPI Timing Parameters^[4]

Parameter	Description	Min	Max	Units
f_{op}	Operating frequency	0	33	MHz
t_{sck}	Cycle time	30	–	ns
t_{wsck}	Clock HIGH/LOW time	13.5	–	ns
t_{lead}	SSN-SCK lead time	$1/2 t_{sck}^{[5]} - 5$	$1.5 t_{sck}^{[5]} + 5$	ns
t_{lag}	Enable lag time	0.5	$1.5 t_{sck}^{[5]} + 5$	ns
t_{rf}	Rise/fall time	–	8	ns
t_{sdd}	Output SSN to valid data delay time	–	5	ns
t_{dv}	Output data valid time	–	5	ns
t_{di}	Output data invalid	0	–	ns
t_{ssnh}	Minimum SSN HIGH time	10	–	ns
t_{sdi}	Data setup time input	8	–	ns
t_{hoi}	Data hold time input	0	–	ns
t_{dis}	Disable data output on SSN HIGH	0	–	ns

Notes

4. All parameters guaranteed by design and validated through characterization.
5. Depends on LAG and LEAD setting in the SPI_CONFIG register.

Reset Sequence

CX3's hard reset sequence requirements are specified in this section.

Table 18. Reset and Standby Timing Parameters

Parameter	Definition	Conditions	Min (ms)	Max (ms)
t_{RPW}	Minimum RESET# pulse width	Clock Input	1	–
t_{RH}	Minimum HIGH on RESET#	–	5	–
t_{RR}	Reset recovery time (after which the boot loader begins firmware download)	Clock Input	1	–
t_{SBY}	Time to enter standby/suspend mode (from the time MAIN_CLOCK_EN/ MAIN_POWER_EN bit is set)	–	–	1
t_{WU}	Time to wakeup from standby	Clock Input	1	–
t_{WH}	Minimum time before standby/suspend source may be reasserted	–	5	–

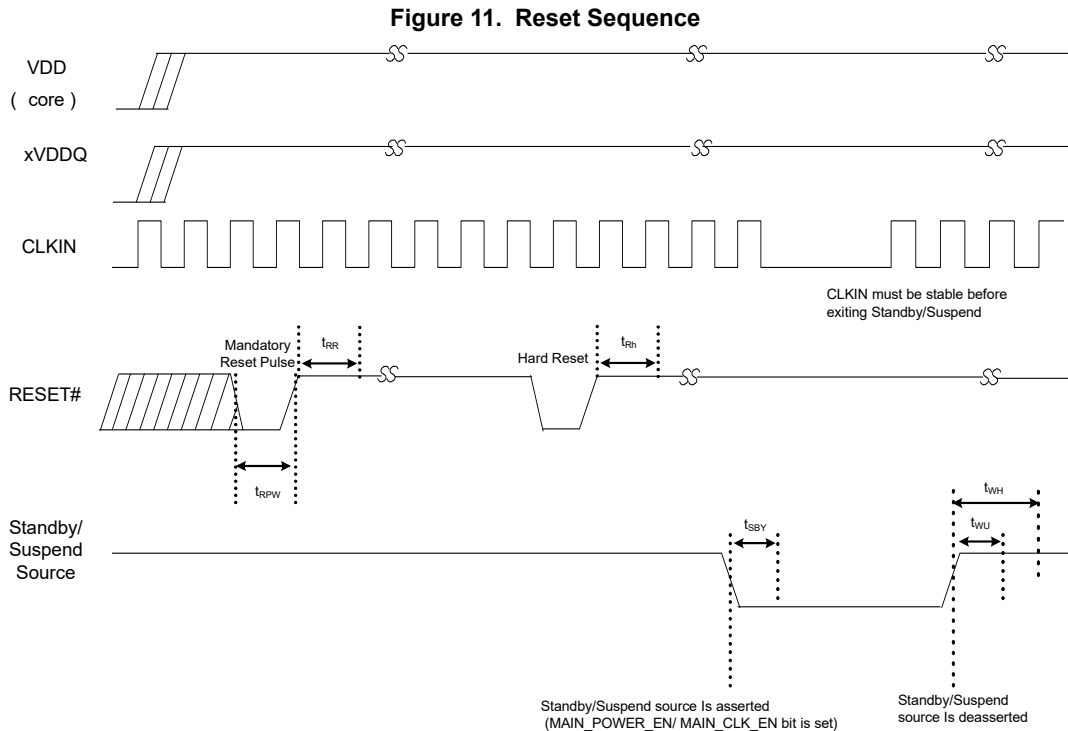

Ordering Information

Table 19. Ordering Information

Ordering Code	MIPI CSI-2 Lanes	Package Type	Temperature Grade
CYUSB3065-BZXI	4	121-ball BGA	Industrial
CYUSB3065-BZXC	4	121-ball BGA	Commercial
CYUSB3064-BZXI	2	121-ball BGA	Industrial
CYUSB3064-BZXC	2	121-ball BGA	Commercial

Ordering Code Definitions

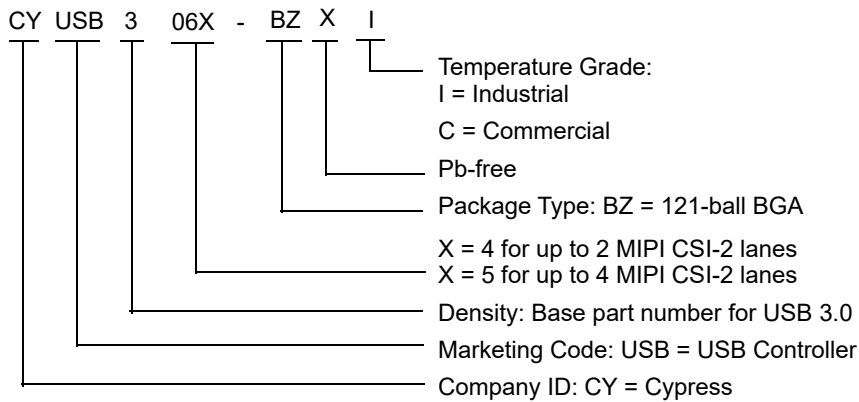

Package Diagram

Figure 12. 121-ball BGA (10 × 10 × 1.7 mm) Package Outline, 001-87293

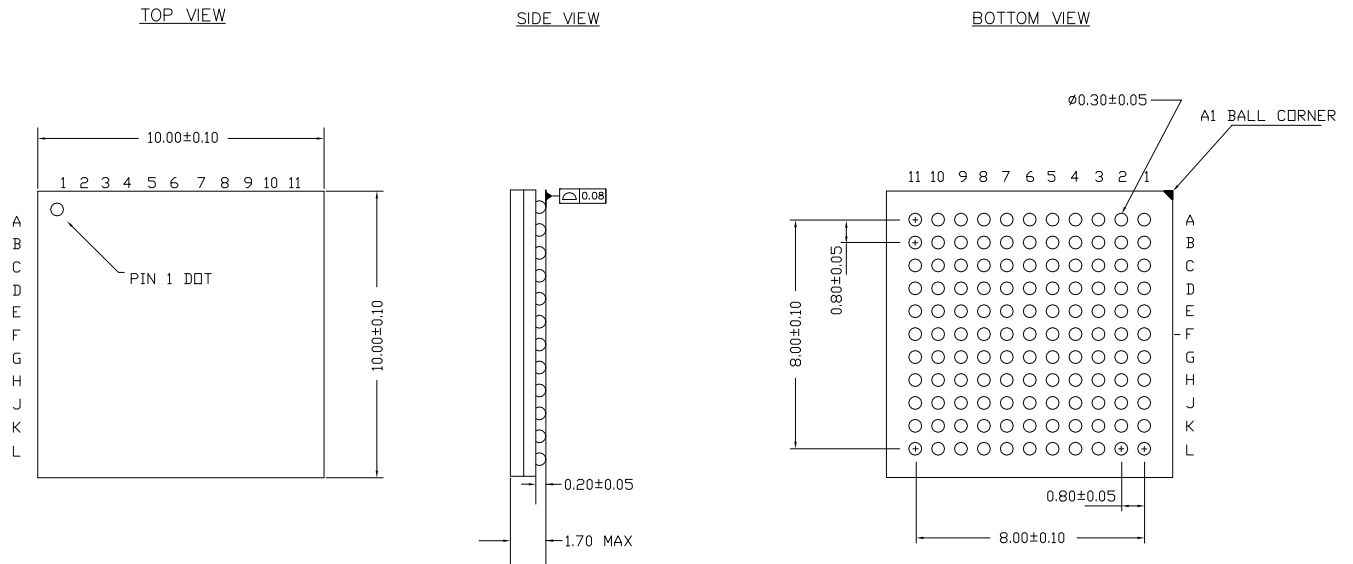

NOTES:

1. ALL DIMENSIONS ARE IN MILLIMETERS
2. REFERENCE JEDEC : PUB 95, DESIGN GUIDE 4.5

001-87293 **

Acronyms

Table 20. Acronyms Used in this Document

Acronym	Description
CSI - 2	Camera Serial Interface - 2
DMA	Direct Memory Access
DNU	Do Not Use
HNP	Host Negotiation Protocol
MIPI	Mobile Industry Processor Interface
MMC	Multimedia Card
MTP	Media Transfer Protocol
PLL	Phase Locked Loop
PMIC	Power Management IC
SD	Secure Digital
SDIO	Secure Digital Input / Output
SLC	Single-Level Cell
SPI	Serial Peripheral Interface
SRP	Session Request Protocol
USB	Universal Serial Bus
WLCSP	Wafer Level Chip Scale Package

Document Conventions

Units of Measure

Table 21. Units of Measure

Symbol	Unit of Measure
°C	degree Celsius
Mbps	Megabits per second
MBps	Megabytes per second
MHz	megahertz
μA	microampere
μs	microsecond
mA	milliampere
ms	millisecond
ns	nanosecond
Ω	ohm
pF	picofarad
V	volt

Errata

This section describes the errata for CX3. Details include errata trigger conditions, scope of impact, available workaround, and silicon revision applicability. Contact your local Cypress Sales Representative if you have questions.

Part Numbers Affected

Part Number	Device Characteristics
CYUSB306x-xxxx	All Variants

Qualification Status

Product Status: Production

Errata Summary

The following table defines the errata applicability to available EZ-USB CX3 SuperSpeed USB Controller family devices.

Items	[Part Number]	Silicon Revision	Fix Status
1. Turning off VDDIO1 during Normal, Suspend, and Standby modes causes the CX3 to stop working.	CYUSB306x-xxxx	All	Workaround provided
2. USB enumeration failure in USB boot mode when CX3 is self-powered.	CYUSB306x-xxxx	All	Workaround provided
3. Extra ZLP is generated by the COMMIT action in the GPIF II state.	CYUSB306x-xxxx	All	Workaround provided
4. Invalid PID Sequence in USB 2.0 ISOC data transfer.	CYUSB306x-xxxx	All	Workaround provided
5. USB data transfer errors are seen when ZLP is followed by data packet within same microframe.	CYUSB306x-xxxx	All	Workaround provided
6. Bus collision is seen when the I2C block is used as a master in the I2C Multi-master configuration.	CYUSB306x-xxxx	All	Use CX3 in single-master configuration
7. Low Power U1 Fast-Exit Issue with USB3.0 host controller.	CYUSB306x-xxxx	All	Workaround provided
8. USB data corruption when operating on hosts with poor link quality.	CYUSB306x-xxxx	All	Workaround provided
9. Device treats Rx Detect sequence from the USB 3.0 host as a valid U1 exit LFPS burst.	CYUSB306x-xxxx	All	Workaround provided
10. I2C Data Valid (tVD:DAT) specification violation at 400 kHz with a 40/60 duty cycle.	CYUSB306x-xxxx	All	No workaround needed
11. CX3 Device does not respond correctly to Port Capability Request from Host after multiple power cycles.	CYUSB306x-xxxx	All	Workaround provided

1. Turning off VDDIO1 during Normal, Suspend, and Standby modes causes the CX3 to stop working.**■Problem Definition**

Turning off the VDDIO1 during Normal, Suspend, and Standby modes will cause the CX3 to stop working.

■Parameters Affected

N/A

■Trigger Conditions

This condition is triggered when the VDDIO1 is turned off during Normal, Suspend, and Standby modes.

■Scope Of Impact

CX3 stops working.

■Workaround

VDDIO1 must stay on during Normal, Suspend, and Standby modes.

■Fix Status

No fix. Workaround is required.

2. USB enumeration failure in USB boot mode when CX3 is self-powered.**■Problem Definition**

When CX3 is self-powered and not connected to the USB host, it enters low-power mode and does not wake up when connected to USB host afterwards. This is because the bootloader does not check the VBUS pin on the connector to detect USB connection. It expects that the USB bus is connected to the host when it is powered on.

■Parameters Affected

N/A

■Trigger Conditions

This condition is triggered when CX3 is self-powered in USB boot mode.

■Scope Of Impact

Device does not enumerate.

■Workaround

Reset the device after connecting to USB host.

■Fix Status

No fix. Workaround is required.

3. Extra ZLP is generated by the COMMIT action in the GPIF II state.**■Problem Definition**

When COMMIT action is used in a GPIF-II state without IN_DATA action then an extra Zero Length Packet (ZLP) is committed along with the data packets.

■Parameters Affected

N/A

■Trigger Conditions

This condition is triggered when COMMIT action is used in a state without IN_DATA action.

■Scope Of Impact

Extra ZLP is generated.

■Workaround

Use IN_DATA action along with COMMIT action in the same state.

■Fix Status

No fix. Workaround is required.

4. Invalid PID Sequence in USB 2.0 ISOC data transfer.

■Problem Definition

When the CX3 device is functioning as a high speed USB device with high bandwidth isochronous endpoints, the PID sequence of the ISO data packets is governed solely by the isomult setting. The length of the data packet is not considered while generating the PID sequence during each microframe. For example, even if a short packet is being sent on an endpoint with MULT set to 2; the PID used will be DATA2.

■Parameters Affected

N/A

■Trigger Conditions

This condition is triggered when high bandwidth ISOC transfer endpoints are used.

■Scope Of Impact

ISOC data transfers failure.

■Workaround

This problem can be worked around by reconfiguring the endpoint with a lower isomult setting prior to sending short packets, and then switching back to the original value.

■Fix Status

No fix. Workaround is required.

5. USB data transfer errors are seen when ZLP is followed by data packet within same microframe.

■Problem Definition

Some data transfer errors may be seen if a Zero Length Packet is followed very quickly (within one microframe or 125 μ s) by another data packet on a burst enabled USB IN endpoint operating at super speed.

■Parameters Affected

N/A

■Trigger Conditions

This condition is triggered in SuperSpeed transfer with ZLPs.

■Scope Of Impact

Data failure and lower data speed.

■Workaround

The solution is to ensure that some time is allowed to elapse between a ZLP and the next data packet on burst enabled USB IN endpoints. If this cannot be ensured at the data source, the CyU3PDmaChannelSetSuspend() API can be used to suspend the corresponding USB DMA socket on seeing the EOP condition. The channel operation can then be resumed as soon as the suspend callback is received.

■Fix Status

No fix. Workaround is required.

6. Bus collision is seen when the I²C block is used as a master in the I²C Multi-master configuration.

■Problem Definition

When CX3 is used as a master in the I²C multi-master configuration, there can be occasional bus collisions.

■Parameters Affected

NA

■Trigger Conditions

This condition is triggered only when the CX3 I²C block operates in Multi-master configuration.

■Scope Of Impact

The CX3 I²C block can transmit data when the I²C bus is not idle leading to bus collision.

■Workaround

Use CX3 as a single master.

■Fix Status

No fix.

7. Low Power U1 Fast-Exit Issue with USB3.0 host controller.

■Problem Definition

When CX3 device transitions from Low power U1 state to U0 state within 5 μ s after entering U1 state, the device sometimes fails to transition back to U0 state, resulting in USB Reset.

■Parameters Affected

NA

■Trigger Conditions

This condition is triggered during low power transition mode.

■Scope Of Impact

Unexpected USB warm reset during data transfer.

■Workaround

This problem can be worked around in the FW by disabling LPM (Link Power Management) during data transfer.

■Fix Status

FW workaround is proven and reliable.

8. USB data corruption when operating on hosts with poor link quality.

■Problem Definition

If CX3 is operating on a USB 3.0 link with poor signal quality, the device could send corrupted data on any of the IN endpoints (including the control endpoint).

■Parameters Affected

NA

■Trigger Conditions

This condition is triggered when the USB3.0 link signal quality is very poor.

■Scope Of Impact

Data corruption in any of the IN endpoints (including the control endpoint).

■Workaround

The application firmware should perform an error recovery by stalling the endpoint on receiving `CYU3P_USBEPPSS_RESET_EVT` event (available only with SDK 1.3.3 and above), and then stop and restart DMA path when the `CLEAR_FEATURE` request is received.

Note: For more details in application firmware, please refer to [GpiftoUsb](#) example available with FX3 SDK.

■Fix Status

FW Work-around is proven and reliable.

9. Device treats Rx Detect sequence from the USB 3.0 host as a valid U1 exit LFPS burst.**■Problem Definition**

The USB 3.0 PHY in the CX3 device uses an electrical idle detector to determine whether LFPS is being received. The duration for which the receiver does not see an electrical idle condition is timed to detect various LFPS bursts. This implementation causes the device to treat an Rx Detect sequence from the USB host as a valid U1 exit LFPS burst.

■Parameters Affected

NA

■Trigger Conditions

This condition is triggered when the USB host is initiating an Rx Detect sequence while the USB 3.0 Link State Machine on the CX3 is in the U1 state. Since the host will only perform Rx Detect sequence in the RX Detect and U2 states, the error condition is seen only in cases where the USB link on the host has moved into the U2 state while the link on CX3 is in the U1 state.

■Scope Of Impact

CX3 moves into Recovery prematurely leading to a Recovery failure followed by Warm Reset and USB re-enumeration. This sequence can repeat multiple times resulting in data transfer failures.

■Workaround

CX3 can be configured to transition from U1 to U2 a few microseconds before the host does so. This will ensure that the link will be in U2 on the device side before the host attempts any Rx Detect sequence; thereby preventing a false detection of U1 exit.

■Fix Status

Workaround is implemented in SDK library 1.3.4 and above.

10. I²C Data Valid (t_{VD:DAT}) specification violation at 400 kHz with a 40/60 duty cycle.**■Problem Definition**

I²C Data Valid (t_{VD:DAT}) parameter at 400 kHz with a 40/60 duty cycle is 1.0625 μ s, which exceeds the I²C specification limit of 0.9 μ s.

■Parameters Affected

N/A

■Trigger Conditions

This violation occurs only at 400 kHz with a 40/60 duty cycle of the I²C clock.

■Scope Of Impact

Setup time (t_{SUDAT}) is met with a huge margin for the transmitted data for 400 kHz and so t_{VD:DAT} violation will not cause any data integrity issues.

■Workaround

No workaround needed.

■Fix Status

No fix needed.

11. CX3 Device does not respond correctly to Port Capability Request from Host after multiple power cycles.**■Problem Definition**

During multiple power cycles, sometimes the CX3 device does not respond correctly to the Port Capability request (Link Packet) from the USB Controller. In view of this, CX3 does not get the subsequent Port Configuration request from the USB controller, resulting in SS.Disabled state. The device fails to recover from this state and finally results in enumeration failure.

■Parameters Affected

N/A

■Trigger Conditions

This condition is triggered when the CX3 provides an incorrect response to the Port Capability request from the host.

■Scope Of Impact

Device fails to enumerate after multiple retries.

■Workaround

Since the host does not send the Port Configuration request to the CX3 device, it causes a Port Configuration request timeout interrupt to be triggered in the device. This interrupt is handled in the FX3 SDK 1.3.4 onwards to generate and signal CY_U3P_US-B_EVENT_LMP_EXCH_FAIL event to the application. This event should be handled in the user application such that it does a USB Interface Block Restart. Refer the Knowledge Base Article ([KBA225778](#)) for more details and the firmware workaround example project.

■Fix Status

Suggested firmware work-around is proven and reliable.

Document History Page

Document Title: CYUSB306X, EZ-USB [®] CX3: MIPI CSI-2 to SuperSpeed USB Bridge Controller			
Document Number: 001-87516			
Revision	ECN	Submission Date	Description of Change
**	3994736	05/09/2013	New data sheet.
*A	4065766	07/17/2013	Replaced "VBUS" and "VBATT" by "VUSB" in all instances across the document. Updated Logic Block Diagram . Updated Pin Description : Updated Table 6 . Updated DC Specifications : Removed V_{BATT} , V_{BUS} , V_{OH_MIPI} , V_{OL_MIPI} parameters and their details. Added V_{USB} parameter and its details. Changed maximum value of V_{RAMP} parameter from 50 V/ms to 12 V/ms. Updated to new template.
*B	4080302	07/29/2013	Changed status from Final to Preliminary.
*C	4088328	08/06/2013	Updated Pin Configuration : Updated Figure 5 .
*D	4113754	09/04/2013	Updated Clocking : Updated description (Added a Note at the bottom of section). Updated Pin Description : Updated Table 6 . Updated DC Specifications : Updated details in "Description" column corresponding to V_{DDIO2} , V_{DDIO3} parameters. Changed maximum value of I_{CC} Core parameter from 200 mA to 380 mA.
*E	4188453	11/14/2013	Changed status from Preliminary to Final. Updated Features : Updated description. Updated Applications : Updated description. Updated Logic Block Diagram . Updated MIPI CSI-2 RX Interface : Updated Additional Outputs : Updated description. Updated Reset : Updated Soft Reset : Updated description. Updated Power . Updated Power Modes . Updated Table 5 : Updated details in "Methods of Entry" column corresponding to "Suspend Mode with USB 3.0 PHY Enabled". Updated details in "Characteristics" column corresponding to "Standby Mode". Updated EMI : Updated description. Updated System-level ESD : Updated description. Updated Pin Configuration : Updated Figure 5 (Updated details of G4, H4, L4, F1, F5, E1, E5, E4, D1, D2, D3, D4, C1, C2, D5, C11 pins). Updated Pin Description : Updated Table 6 : Updated details in "Pin name" column for G4, H4, L4, F1, F5, E1, E5, E4, D1, D2, D3, D4, C1, C2, D5, C11 pins.

Document History Page (continued)

Document Title: CYUSB306X, EZ-USB® CX3: MIPI CSI-2 to SuperSpeed USB Bridge Controller			
Document Number: 001-87516			
Revision	ECN	Submission Date	Description of Change
*E (cont.)	4188453	11/14/2013	<p>Updated Absolute Maximum Ratings: Removed "Ambient temperature with power applied" and its corresponding details. Removed "Static discharge voltage ESD protection levels" and its corresponding details. Removed "Latch-up current" and its corresponding details. Added "Maximum latch-up current" and its corresponding details. Updated DC Specifications: Updated details in "Notes" column corresponding to V_{IH1} and V_{IH2} parameters. Updated details in "Description" column corresponding to I_{OZ} parameter. Updated details in "Min" column corresponding to I_{SB1} and I_{SB3} parameters. Updated details in "Notes" column corresponding to I_{SB1} and I_{SB3} parameters. Added MIPI D-PHY Electrical Characteristics. Updated AC Timing Parameters: Updated MIPI Data to Clock Timing Reference: Updated Figure 6. Updated Table 11: Added 1 ns under "Min" column corresponding to $U_{I_{INST}}$ parameter. Changed maximum value of T_{CLKP} parameter from 2 ns to 25 ns. Updated MIPI CSI Signal Low Power AC Characteristics: Updated Figure 7. Updated Serial Peripherals Timing: Updated I2C Timing: Updated Table 15: Removed "(Not supported at I2C_VDDQ = 1.2 V)" in "I2C Fast Mode Plus Parameters" sub-heading. Updated Reset Sequence. Updated Table 18: Removed "Crystal Input" condition for t_{RPW}, t_{RR}, t_{WU} parameters. Updated Figure 11. Updated Ordering Information: Updated part numbers.</p>
*F	4214952	03/12/2014	<p>Updated Features: Updated description. Updated Application Examples: Updated Figure 1. Updated Configuration Options: Updated description (Added e-mail). Updated Pin Description. Updated Table 6 (caption only). Updated AC Timing Parameters: Updated MIPI CSI Signal Low Power AC Characteristics: Updated Table 13: Updated details in "Notes" column corresponding to e_{SPIKE} parameter. Updated to new template.</p>
*G	4417040	06/23/2014	<p>Updated Power: Updated description (Updated details corresponding to "IO_VDDQ" power supply domain). Updated DC Specifications: Changed maximum value of I_{CC} Core parameter 380 mA to 192 mA.</p>
*H	4467092	08/06/2014	<p>Added CYUSB3064 part related information in all instances across the document. Updated Pin Configuration: Updated Figure 5. Added footnote 2. Updated Pin Description: Updated Table 6. Updated Ordering Information: Updated part numbers.</p>

Document History Page (continued)

Document Title: CYUSB306X, EZ-USB [®] CX3: MIPI CSI-2 to SuperSpeed USB Bridge Controller			
Document Number: 001-87516			
Revision	ECN	Submission Date	Description of Change
*I	4862446	08/13/2015	Updated Pin Configuration : Updated Figure 5 . Added footnote 1. Updated Pin Description : Updated Table 6 .
*J	4974015	10/19/2015	Added More Information .
*K	5283275	05/24/2016	Updated to new template. Completing Sunset Review.
*L	5464498	06/22/2017	Updated Power : Updated description. Updated Operating Conditions : Replaced "3.2 V" with "4 V" in Operating Conditions corresponding to "V _{USB} supply voltage". Updated DC Specifications : Changed minimum value of V _{USB} parameter from 3.2 V to 4 V. Added Errata . Updated to new template.
*M	6237413	09/28/2018	Updated Features : Updated description. Updated More Information : Updated description. Updated Other Interfaces : Updated I2S Interface : Updated description. Updated Boot Options : Updated description. Updated Electrical Specifications : Updated Operating Conditions : Added Commercial Temperature Range related information. Updated DC Specifications : Updated Table 7 . Added Table 8 . Added Thermal Characteristics . Updated Errata : Updated Errata Summary : Updated description. Added items "Low Power U1 Fast-Exit Issue with USB3.0 host controller.", "USB data corruption when operating on hosts with poor link quality.", "Device treats Rx Detect sequence from the USB 3.0 host as a valid U1 exit LFPS burst.", "I ² C Data Valid (tVD:DAT) specification violation at 400 kHz with a 40/60 duty cycle." and their corresponding details in the table. Updated to new template.
*N	6409378	12/12/2018	Updated Errata : Updated Errata Summary : Updated description. Added item "CX3 Device does not respond correctly to Port Capability Request from Host after multiple power cycles." and its corresponding details in the table.
*O	7268511	09/02/2021	Updated Clocking : Updated description (Updated Note). Updated to new template. Completing Sunset Review.

Sales, Solutions, and Legal Information

Worldwide Sales and Design Support

Cypress maintains a worldwide network of offices, solution centers, manufacturer's representatives, and distributors. To find the office closest to you, visit us at [Cypress Locations](#).

Products

Arm® Cortex® Microcontrollers	cypress.com/arm
Automotive	cypress.com/automotive
Clocks & Buffers	cypress.com/clocks
Interface	cypress.com/interface
Internet of Things	cypress.com/iot
Memory	cypress.com/memory
Microcontrollers	cypress.com/mcu
PSoC	cypress.com/psoc
Power Management ICs	cypress.com/pmic
Touch Sensing	cypress.com/touch
USB Controllers	cypress.com/usb
Wireless Connectivity	cypress.com/wireless

PSoC® Solutions

[PSoC 1](#) | [PSoC 3](#) | [PSoC 4](#) | [PSoC 5LP](#) | [PSoC 6 MCU](#)

Cypress Developer Community

[Community](#) | [Code Examples](#) | [Projects](#) | [Video](#) | [Blogs](#) | [Training](#) | [Components](#)

Technical Support

cypress.com/support

© Cypress Semiconductor Corporation, 2013–2021. This document is the property of Cypress Semiconductor Corporation, an Infineon Technologies company, and its affiliates ("Cypress"). This document, including any software or firmware included or referenced in this document ("Software"), is owned by Cypress under the intellectual property laws and treaties of the United States and other countries worldwide. Cypress reserves all rights under such laws and treaties and does not, except as specifically stated in this paragraph, grant any license under its patents, copyrights, trademarks, or other intellectual property rights. If the Software is not accompanied by a license agreement and you do not otherwise have a written agreement with Cypress governing the use of the Software, then Cypress hereby grants you a personal, non-exclusive, nontransferable license (without the right to sublicense) (1) under its copyright rights in the Software (a) for Software provided in source code form, to modify and reproduce the Software solely for use with Cypress hardware products, only internally within your organization, and (b) to distribute the Software in binary code form externally to end users (either directly or indirectly through resellers and distributors), solely for use on Cypress hardware product units, and (2) under those claims of Cypress's patents that are infringed by the Software (as provided by Cypress, unmodified) to make, use, distribute, and import the Software solely for use with Cypress hardware products. Any other use, reproduction, modification, translation, or compilation of the Software is prohibited.

TO THE EXTENT PERMITTED BY APPLICABLE LAW, CYPRESS MAKES NO WARRANTY OF ANY KIND, EXPRESS OR IMPLIED, WITH REGARD TO THIS DOCUMENT OR ANY SOFTWARE OR ACCOMPANYING HARDWARE, INCLUDING, BUT NOT LIMITED TO, THE IMPLIED WARRANTIES OF MERCHANTABILITY AND FITNESS FOR A PARTICULAR PURPOSE. No computing device can be absolutely secure. Therefore, despite security measures implemented in Cypress hardware or software products, Cypress shall have no liability arising out of any security breach, such as unauthorized access to or use of a Cypress product. CYPRESS DOES NOT REPRESENT, WARRANT, OR GUARANTEE THAT CYPRESS PRODUCTS, OR SYSTEMS CREATED USING CYPRESS PRODUCTS, WILL BE FREE FROM CORRUPTION, ATTACK, VIRUSES, INTERFERENCE, HACKING, DATA LOSS OR THEFT, OR OTHER SECURITY INTRUSION (collectively, "Security Breach"). Cypress disclaims any liability relating to any Security Breach, and you shall and hereby do release Cypress from any claim, damage, or other liability arising from any Security Breach. In addition, the products described in these materials may contain design defects or errors known as errata which may cause the product to deviate from published specifications. To the extent permitted by applicable law, Cypress reserves the right to make changes to this document without further notice. Cypress does not assume any liability arising out of the application or use of any product or circuit described in this document. Any information provided in this document, including any sample design information or programming code, is provided only for reference purposes. It is the responsibility of the user of this document to properly design, program, and test the functionality and safety of any application made of this information and any resulting product. "High-Risk Device" means any device or system whose failure could cause personal injury, death, or property damage. Examples of High-Risk Devices are weapons, nuclear installations, surgical implants, and other medical devices. "Critical Component" means any component of a High-Risk Device whose failure to perform can be reasonably expected to cause, directly or indirectly, the failure of the High-Risk Device, or to affect its safety or effectiveness. Cypress is not liable, in whole or in part, and you shall and hereby do release Cypress from any claim, damage, or other liability arising from any use of a Cypress product as a Critical Component in a High-Risk Device. You shall indemnify and hold Cypress, including its affiliates, and its directors, officers, employees, agents, distributors, and assigns harmless from and against all claims, costs, damages, and expenses, arising out of any claim, including claims for product liability, personal injury or death, or property damage arising from any use of a Cypress product as a Critical Component in a High-Risk Device. Cypress products are not intended or authorized for use as a Critical Component in any High-Risk Device except to the limited extent that (i) Cypress's published data sheet for the product explicitly states Cypress has qualified the product for use in a specific High-Risk Device, or (ii) Cypress has given you advance written authorization to use the product as a Critical Component in the specific High-Risk Device and you have signed a separate indemnification agreement.

Cypress, the Cypress logo, and combinations thereof, PSoC, CapSense, EZ-USB, F-RAM, Traveo, WICED, and ModusToolbox are trademarks or registered trademarks of Cypress or a subsidiary of Cypress in the United States or in other countries. For a more complete list of Cypress trademarks, visit cypress.com. Other names and brands may be claimed as property of their respective owners.