



BETA TRANSFORMER TECHNOLOGY CORPORATION

A Subsidiary of Data Device Corporation
40 Orville Drive, Bohemia, NY 11716-2529
Phone: (631) 244-7393; Fax: (631) 244-8893
Web site: www.bttc-beta.com

PULSE TRANSFORMERS

MIL-STD-1553 TRANSFORMERS

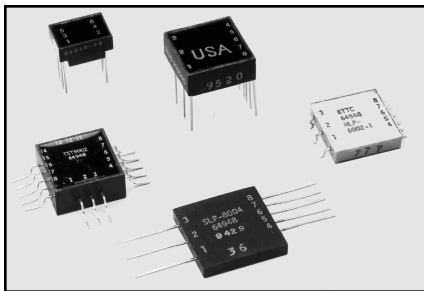

FEATURES

- **Complete Line of Custom and QPL Units**
- **For Use with MIL-STD-1553A and B, MacAir A-5690, A-5232, and A-4905**
- **Low Profile**
- **Epoxy Cased, Hermetically Sealed**
- **-55°C to +130°C Operating Temperature Range**
- **Built and Tested to MIL-PRF-21038 and MIL-STD-202**

DESCRIPTION AND APPLICATIONS

The military data bus specification, MIL-STD-1553, has brought about the need for versatile pulse transformers that meet all the electrical requirements of Manchester II serial biphas data transmission. Our various package styles provide the turns ratio configurations, component isolation, and common-mode rejection ratio characteristics necessary for MIL-STD-1553A and B compliance.

The step-up and step-down ratios complement DDC's entire MIL-STD-1553 product line and are compatible with competitors' drivers, receivers and transceivers. Hermetically sealed or epoxy cased, these transformers are multitapped to accommodate existing system configurations. Encapsulated in accordance with MIL-PRF-21038, their tin-coated, copper-clad steel leads (epoxy-cased units) conveniently accommodate printed circuit board mounting. Sinusoidal or trapezoidal waveforms are accurately processed, making these transformers an excellent choice for any MIL-STD-1553A or B application.

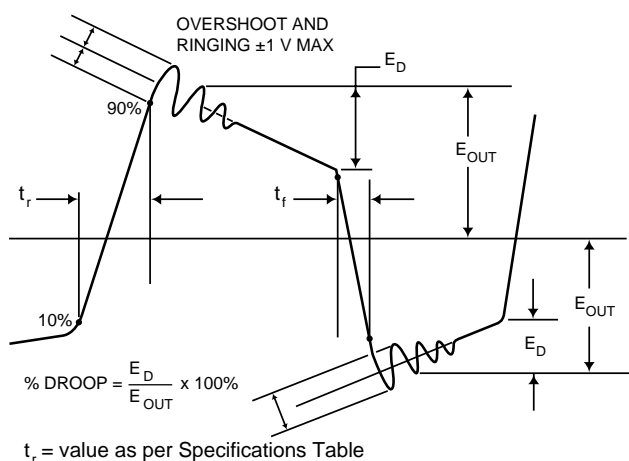

FIGURE 1. WAVEFORM INTEGRITY

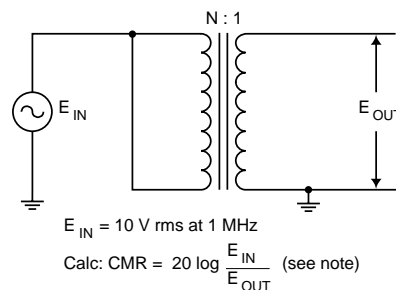
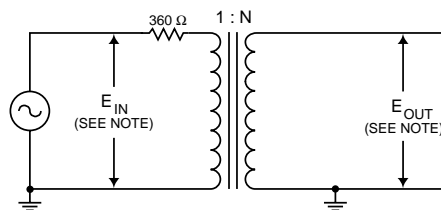

FIGURE 2. CIRCUIT FOR COMMON-MODE REJECTION



$E_{IN} = 250$ kHz square wave, 27.0 volts peak-to-peak with a rise and fall time no greater than 100 ns.

Calc : Droop = $\frac{E_D}{E_{OUT}} \times 100\%$. (see figure 1 for E_D)

FIGURE 3. CIRCUIT FOR WAVEFORM INTEGRITY

Note: Input to be applied and output to be measured for all dash numbers as shown. N represents highest turns winding in each test.

PULSE TRANSFORMER CROSS REFERENCE LIST₁

TRANSCIEVER TYPE	PIN NOS.	TURNS RATIO	TRANSFORMER CHARACTERISTICS							
			-Epoxy Unit -PC Mount -Ht. (see below) -Config. A -*Config. A	-Epoxy Unit -Flat pack -0.275" Ht. -Config. B	-Epoxy Unit -Surface Mt. -0.275" Ht. -Config. C	-Epoxy Unit -Flat pack -LPB Series -0.150" Ht. -Config. D	-Epoxy Unit -Surface Mt. -LPB Series -0.150" Ht. -Config. E	-Epoxy Unit -PC Mount -TST 9000 Series -0.280" Ht. -Config. F	-Epoxy Unit -Surface Mt. -TST 9000 Series -0.280" Ht. -Config. G	
1	1-3:4-8 1-3:5-7	1.4:1 2:1	0.250" Ht. *25679 B-2203 (-02)	B-2343 (-17)	B-2387 (-12)	LPB-5009	LPB-5002	TST-9002	TST-9012	
3A	1-3:4-8 1-3:5-7	1:2.5 1:1.75	0.220" Ht. *41429	B-3076	B-3110	LPB-5007	LPB-5000	TST-9000	TST-9010	
2	1-3:4-8 1-3:5-7	1.20:1 1.67:1	0.275" Ht. *29854	B-3078	B-3063	LPB-5008	LPB-5001	TST-9001	TST-9011	
5	1-3:4-8 1-3:5-7	1:1 1:0.707	0.300" Ht. *27765 B-2202 (-01)	B-2342 (-16)	B-2386 (-11)	LPB-5010	LPB-5003	TST-9003	TST-9013	
3	1-3:4-8 1-3:5-7	1:2.5 1:1.79	0.250" Ht. B-3226 (-26)	B-3231 (-31)	B-3227 (-27)	LPB-5014	LPB-5015	TST-9007	TST-9017	
	4-8:1-3 5-7:1-3	2.3:1 3.2:1	0.300" Ht. B-2205 (-04)	B-2345 (-19)	B-2389 (-14)	LPB-5012	LPB-5005	TST-9005	TST-9015	
2	1-3:4-8 1-3:5-7	1.25:1 1.66:1	0.250" Ht. B-2204 (-03)	B-2344 (-18)	B-2388 (-13)	LPB-5011	LPB-5504	TST-9004	TST-9014	
	4-8:1-3 5-7:1-3	2.12:1 1.5:1	0.250" Ht. B-2385 (-10)	B-2391 (-20)	B-2390 (-15)	LPB-5013	LPB-5006	TST-9006	TST-9016	



SPECIFICATIONS

PARAMETER	VALUE										UNITS
	BUS-25679	B-2203	BUS-27765	B-2202	BUS-29854	BUS-41429	B-3226	B-2205	B-2204	B-2385	
FREQUENCY RESPONSE Operating Range	75 to 1000	75 to 1000	75 to 1000	75 to 1000	75 to 1000	75 to 1000	75 to 1000	75 to 1000	75 to 1000	75 to 1000	kHz
COMMON-MODE REJECTION (CMR)	45 min.	45 min.	45 min.	45 min.	50 min.	45 min.	45 min.	45 min.	45 min.	45 min.	dB
ELECTRICAL REQUIREMENTS Terminal winding Resistance (RDC) ₂ • 1-3 • 4-8 Interwinding Capacitance Intrawinding Capacitance Winding Inductance • 1-3 • 4-8	3.5 max. 3.0 max. 70 max. - 7.5 min. 12 max.	3.5 max. 3.0 max. 70 max. - 7.5 min. 12 max.	3 max. 3 max. - 30 max. 7.5 min. 6 max.	3 max. 3 max. - 30 max. 7.5 min. 6 max.	1.9 max. 1.9 max. 70 max. - 7.5 min. 6 max.	1.0 max. 3.0 max. 45 max. - 6.0 min. -	1.0 max. 3.0 max. 45 max. - 6.0 min. -	1.2 max. 3.0 max. 70 max. - 8.0 min. 7 max.	3.2 max. 3.0 max. 70 max. - 7.5 min. 7 max.	1.0 max. 3.0 max. 70 max. - 6.0 min. 6 max.	Ω Ω pF mH μH
PEAK-TO-PEAK VOLTAGE Terminals 1, 3 (Primary)	60 max.	60 max.	39.2 max.	39.2 max.	60 max.	60 max.	60 max.	60 max.	60 max.	60 max.	Vpp
PEAK PULSE CURRENTS (AC)₃ Terminals 1, 3 (Primary)	180 max.	180 max.	140 max.	140 max.	180 max.	180 max.	180 max.	180 max.	180 max.	180 max.	mA
DROOP	20 max.	20 max.	20 max.	20 max.	20 max.	20 max.	20 max.	20 max.	20 max.	20 max.	%
RISE TIME	150 max.	150 max.	150 max.	150 max.	150 max.	150 max.	250 max.	150 max.	150 max.	200 max.	ns
DECAY TIME₃	25 max.	25 max.	25 max.	25 max.	25 max.	25 max.	25 max.	25 max.	25 max.	25 max.	ns
OVERSHOOT	±1	±1	±1	±1	±1	±1	±1	±1	±1	±1	Vp
BACKSWING₃	none	none	none	none	none	none	none	none	none	none	
TURNS RATIO Terminals • 1,3:4,8 • 1,3:5,7 Winding Tolerance (CT ±5%)	1.4CT:1CT 2CT:1CT 3	1.4CT:1CT 2CT:1CT 3	1CT:1CT 1CT:0.707CT 3	1CT:1CT 1CT:0.707CT 3	1.20CT:1CT 1.67CT:1CT 3	1CT:2.5CT 1CT:1.75CT 3	1CT:2.5CT 1CT:1.79CT 3	1CT2.3CT 1CT:3.2CT 3	1.25CT:1CT 1.66CT:1CT 3	1CT:2.12CT 1CT:1.5CT 3	±%
TEMPERATURE REQUIREMENTS Operating (ambient) Storage	-55 to +125 -55 to +130	-55 to +130 -55 to +130	-55 to +125 -55 to +130	-55 to +130 -55 to +130	-55 to +125 -55 to +130	-55 to +125 -55 to +130	-55 to +130 -55 to +130	-55 to +130 -55 to +130	-55 to +130 -55 to +130	-55 to +130 -55 to +130	°C °C
PHYSICAL CHARACTERISTICS₂ Size Weight	0.63 x 0.63 x Ht. (16 x 16 x Ht.) for all units 0.15 max. (4.26) for all units										in (mm) oz (g)

PULSE TRANSFORMER CROSS REFERENCE LIST ₁ (continued)										
TRANSCEIVER TYPE	PIN NOS.	TURNS RATIO	TRANSFORMER CHARACTERISTICS							
			-Epoxy Unit -Flat pack -TST 9000 Series -0.280" Ht. -Config. H	-Epoxy Unit -PC Mount -TST 9100 Series -0.320" Ht. -Config. I	-Epoxy Unit -Surface Mt. -TST 9100 Series -0.320" Ht. -Config. J	-Epoxy Unit -Flat pack -TST 9100 Series -0.320" Ht. -Config. K	-Epoxy Unit -Flat pack -SLP Series -0.130" Ht. -Config. L	-Epoxy Unit -Surface Mt. -SLP Series -0.130" Ht. -Config. M	-Metal Unit -Flat pack -HLP Series -0.175" Ht. -Config. N	-Metal Unit -Surface Mt. -HLP Series -0.175" Ht. -Config. O
1	1-3:4-8 1-3:5-7	1.4:1 2:1	TST-9022	TST-9102	TST-9112	TST-9122	SLP-8019	SLP-8002	HLP-6009	HLP-6002
3A	1-3:4-8 1-3:5-7	1:2.5 1:1.75	TST-9020	TST-9100	TST-9110	TST-9120	SLP-8017	SLP-8000	HLP-6007	HLP-6000
2	1-3:4-8 1-3:5-7	1.20:1 1.67:1	TST-9021	TST-9101	TST-9111	TST-9121	SLP-8018	SLP-8001	HLP-6008	HLP-6001
5	1-3:4-8 1-3:5-7	1:1 1:0.707	TST-9023	TST-9103	TST-9113	TST-9123	SLP-8020	SLP-8003	HLP-6010	HLP-6003
3	1-3:4-8 1-3:5-7	1:2.5 1:1.79	TST-9027	TST-9107	TST-9117	TST-9127	SLP-8024	SLP-8007	HLP-6014	HLP-6015
	4-8:1-3 5-7:1-3	2.3:1 3.2:1	TST-9025	TST-9105	TST-9115	TST-9125	SLP-8022	SLP-8005	HLP-6012	HLP-6005
2	1-3:4-8 1-3:5-7	1.25:1 1.66:1	TST-9024	TST-9104	TST-9114	TST-9124	SLP-8021	SLP-8004	HLP-6011	HLP-6004
	4-8:1-3 5-7:1-3	2.12:1 1.5:1	TST-9026	TST-9106	TST-9116	TST-9126	SLP-8023	SLP-8006	HLP-6013	HLP-6006

- Notes:
 1. Numbers in parenthesis () reference MIL-PRF-21038 dash numbers.
 2. For configuration "A" only. See individual specifications for actual values.
 3. Design parameter only. Not screened in production.

Transceiver Type 1 (Trapezoidal +5 V/-15 V)

- BU-61580X1
- BU-65170X1
- BUS-61559
- BUS-61553
- BUS-65153
- BUS-65142
- BUS-63105/25II

Consult Factory For:

- MIL-PRF-21038 QPL Part Numbers
- Special Marking
- Special Testing
- Special Packaging
- Source Inspection

Transceiver Type 2 (Trapezoidal +5 V/-12 V)

- BU-61580X2
- BU-65170X2
- BUS-61560
- BUS-61554
- BUS-65154
- BUS-65143
- BUS-63107/27II

Transceiver Type 3 (Monolithic Trapezoidal +5 V)

- BU-61580X3
- BU-65170X3
- BU-61580X6
- BU-65170X6

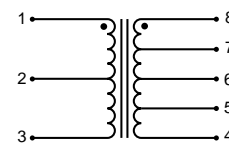
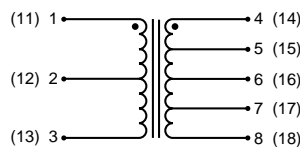

FOR ALL CONFIG. EXCEPT *CONFIG. A

FOR *CONFIG. A ONLY

NOTE: Numbers in () are for TST Series Units.

Transceiver Type 3A (Discrete Trapezoidal +5 V)

- BUS-61561
- BUS-61555
- BUS-63147/48

Transceiver Type 5 (Sinusoidal McAir)

- BU-61590X5
- BUS-65149
- BUS-63102

ORDER BY BETA PART NUMBER FROM ADDRESS AT THE TOP OF THE PAGE

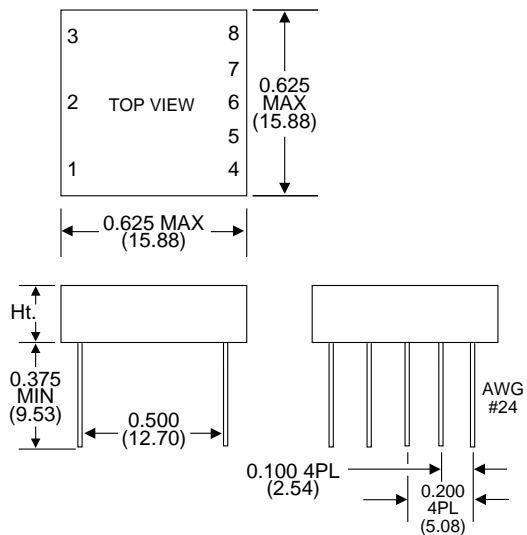

CONFIGURATION A

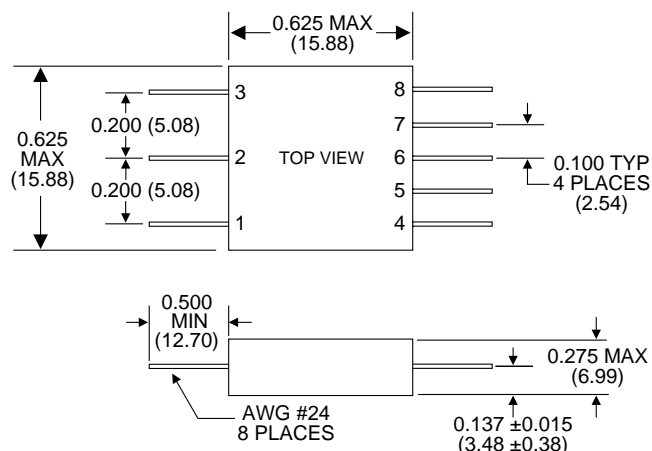

CONFIGURATION B

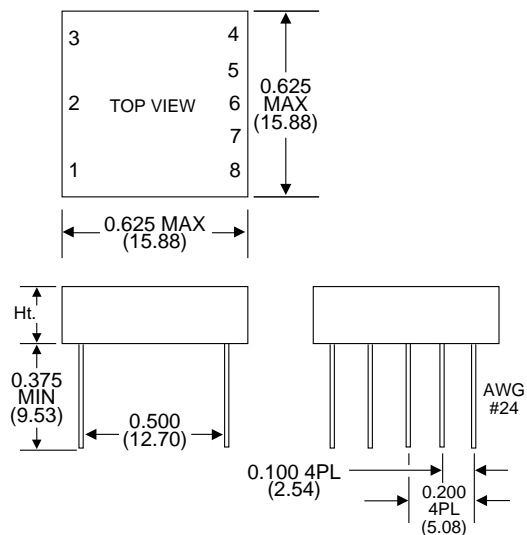

***CONFIGURATION A**

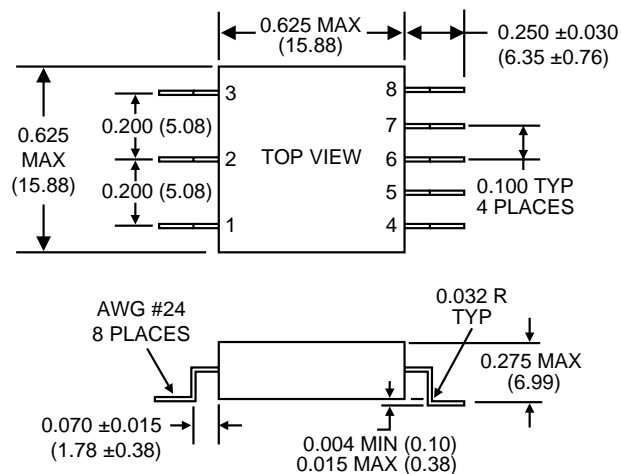

CONFIGURATION C

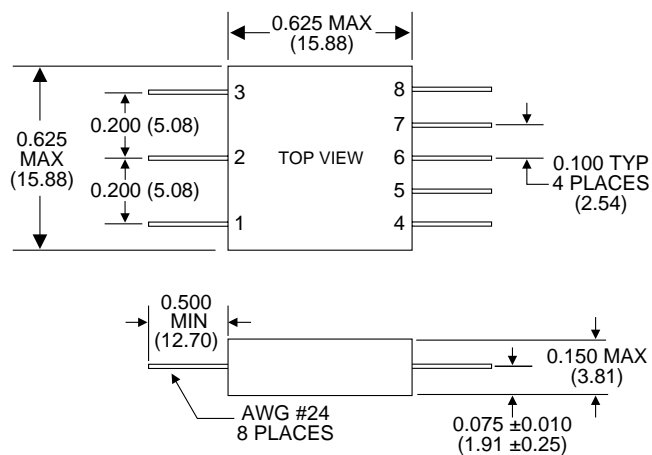

CONFIGURATION D

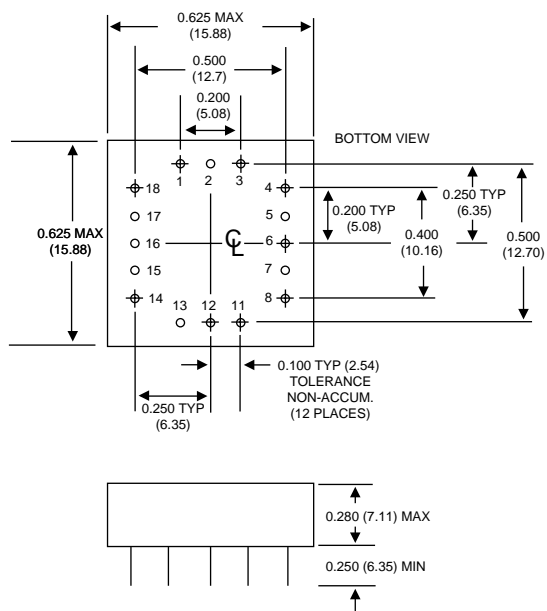

CONFIGURATION F

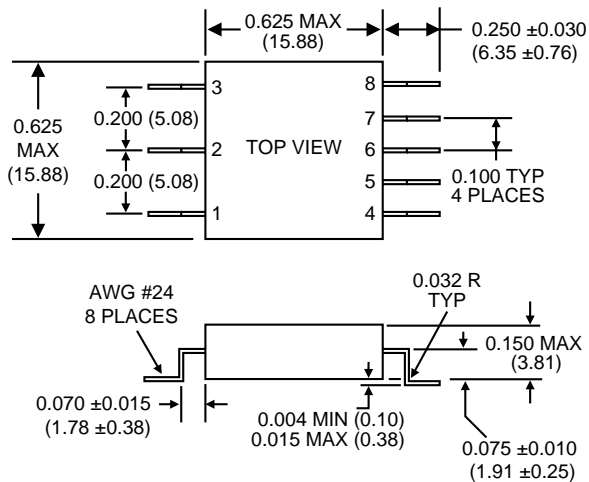

CONFIGURATION E

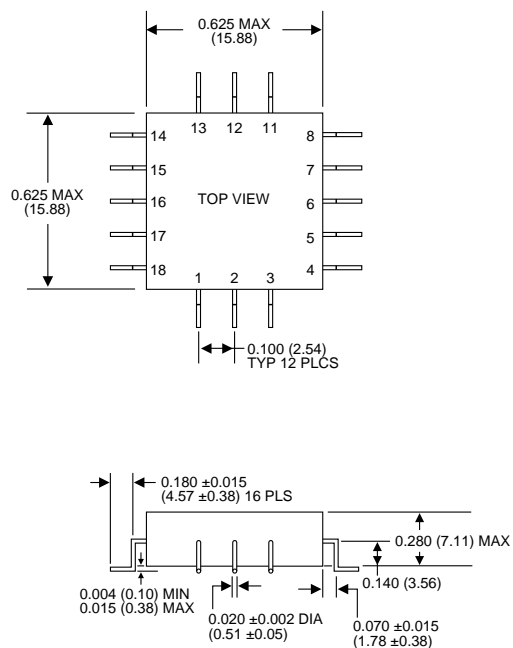

CONFIGURATION G

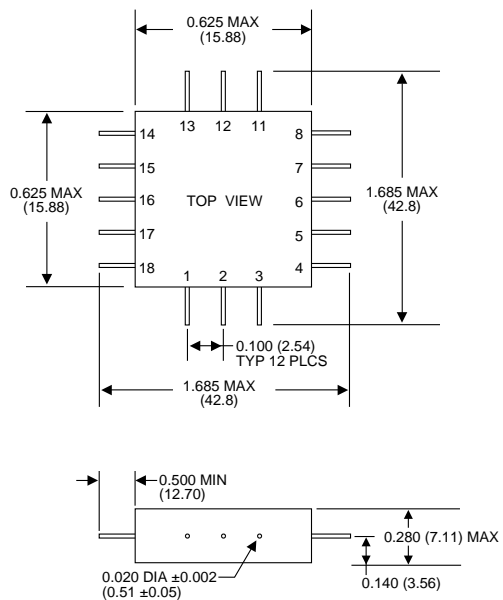

CONFIGURATION H

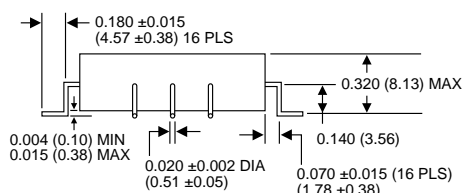
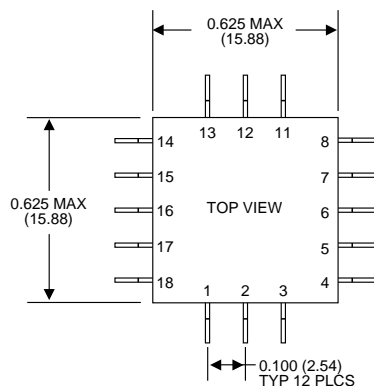

CONFIGURATION J

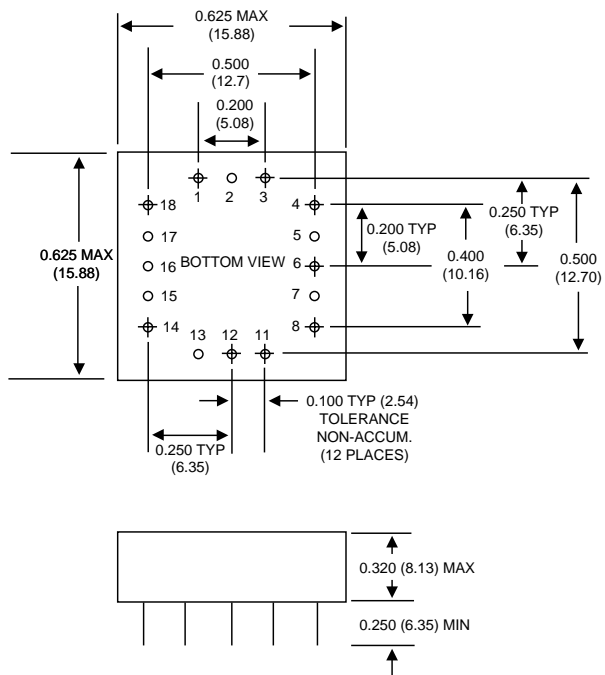

CONFIGURATION I

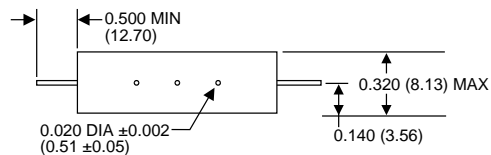
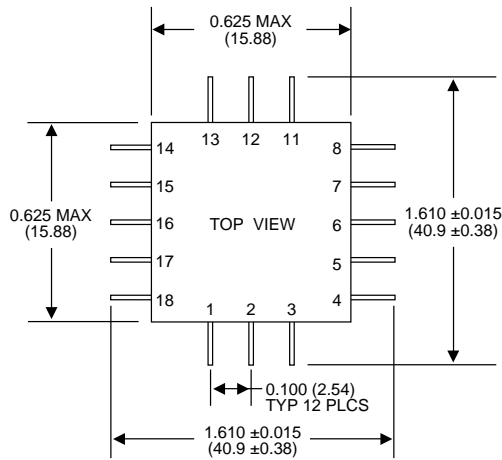

CONFIGURATION K

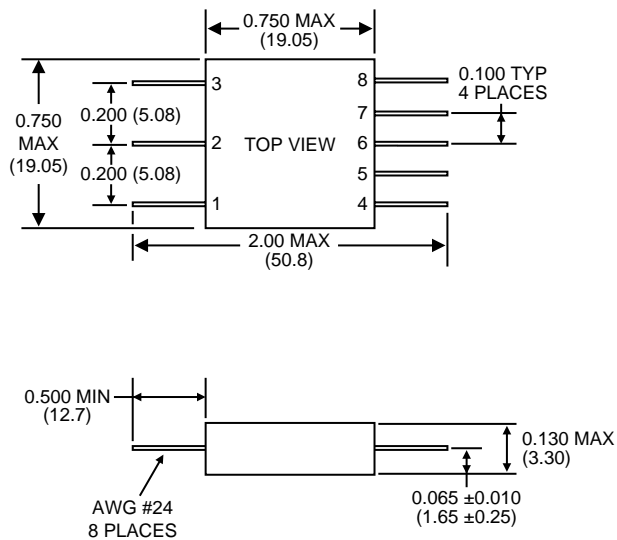

CONFIGURATION L

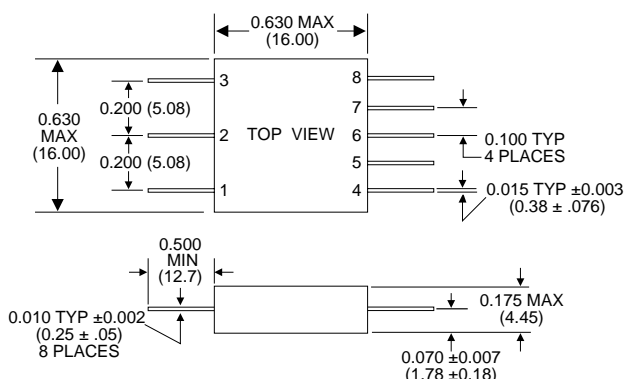

LEADS: GOLD PLATING OVER NICKEL-PLATED KOVAR
CASE: NICKEL-PLATED KOVAR

CONFIGURATION N

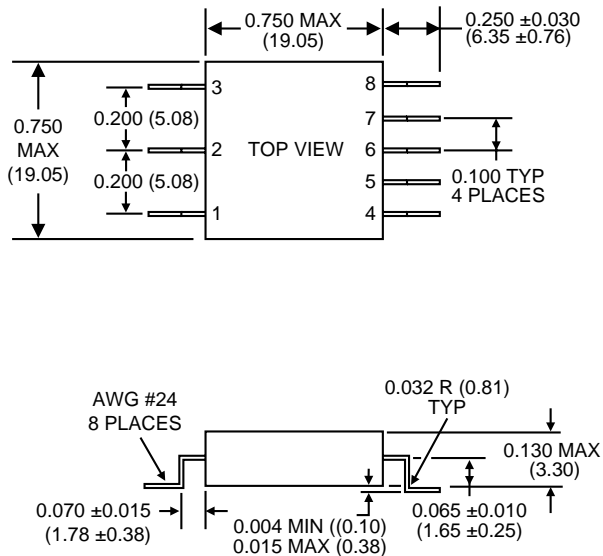

CONFIGURATION M

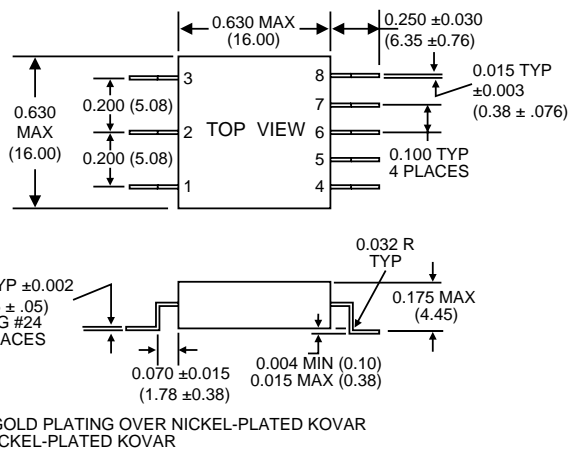

LEADS: GOLD PLATING OVER NICKEL-PLATED KOVAR
CASE: NICKEL-PLATED KOVAR

CONFIGURATION O

The information in this data sheet is believed to be accurate; however, no responsibility is assumed by Beta Transformer Technology Corporation for its use, and no license or rights are granted by implication or otherwise in connection therewith. Specifications are subject to change without notice.



**BETA TRANSFORMER
TECHNOLOGY CORPORATION**

A Subsidiary of Data Device Corporation
40 Orville Drive, Bohemia, NY 11716-2529
Phone: (631) 244-7393; Fax: (631) 244-8893
Web site: www.bttc-beta.com