

# Intel® TXN13220/1/4/5/7/8 SFF 10 Gbps Optical Transceiver with 16-Channel Multiplexer/Demultiplexer

Datasheet

## Product Features

- 10 Gbps Optical Transmitter and Receiver Pair with 16 Channel Multiplexer/Demultiplexer
- Typical Receiver Sensitivity < -14 dBm
- Available in Short-Reach (7 km, 12 km, 25 km) and Intermediate-Reach (40 km) Versions
- 300-Pin Multi-Source Agreement Compatible Form Factor and Pin Configuration
- LVDS Data Interface through 300-Pin, Berg Connector
- Optional Jitter Filter
- 9-Bit-Deep FIFO Buffer
- Integral Heat Sinking Designed for 250 Linear Feet per Minute, 55 °C Ambient Air Flow; Flat Top Version Also Available
- Case Operating Temperature -5 °C to 70 °C
- Laser Bias, Laser Temperature, Laser Power, and Receiver Power Monitors
- Receive and Transmit Loss-of-Lock, Receive Loss-of-Avg-Power, Laser Bias, and Laser Temperature Alarms
- Multi-Rate Capability, Digitally Selectable between SONET 9.953 Gbps and FEC 10.709 Gbps Rates or 10Gb Ethernet 10.3 Gbps
- Includes Active Signal Monitoring and Onboard Microprocessor which Uses the I<sup>2</sup>C Bus
- 1310 nm and 1550 nm Wavelength

## Applications

Client-side interfaces of Metro/Core Equipment, including:

- Core-enterprise Switches, and Routers
- Multi-service Provisioning Platforms
- Cross-Connects
- Add/Drop Multiplexers
- Dense Wavelength Division Multiplex Terminals
- Other WDM and Non-WDM Metro System Equipment
- Optical Test Equipment
- Optical Transport Solutions

Order Number: 273807, 004  
26-Oct-2006



INFORMATION IN THIS DOCUMENT IS PROVIDED IN CONNECTION WITH INTEL® PRODUCTS. NO LICENSE, EXPRESS OR IMPLIED, BY ESTOPPEL OR OTHERWISE, TO ANY INTELLECTUAL PROPERTY RIGHTS IS GRANTED BY THIS DOCUMENT. EXCEPT AS PROVIDED IN INTEL'S TERMS AND CONDITIONS OF SALE FOR SUCH PRODUCTS, INTEL ASSUMES NO LIABILITY WHATSOEVER, AND INTEL DISCLAIMS ANY EXPRESS OR IMPLIED WARRANTY, RELATING TO SALE AND/OR USE OF INTEL PRODUCTS INCLUDING LIABILITY OR WARRANTIES RELATING TO FITNESS FOR A PARTICULAR PURPOSE, MERCHANTABILITY, OR INFRINGEMENT OF ANY PATENT, COPYRIGHT OR OTHER INTELLECTUAL PROPERTY RIGHT. Intel products are not intended for use in medical, life saving, life sustaining, critical control or safety systems, or in nuclear facility applications.

Intel may make changes to specifications and product descriptions at any time, without notice.

Intel Corporation may have patents or pending patent applications, trademarks, copyrights, or other intellectual property rights that relate to the presented subject matter. The furnishing of documents and other materials and information does not provide any license, express or implied, by estoppel or otherwise, to any such patents, trademarks, copyrights, or other intellectual property rights.

The Intel® TXN13220/7/8 Optical Transceiver may contain design defects or errors known as errata which may cause the product to deviate from published specifications. Current characterized errata are available on request.

Contact your local Intel sales office or your distributor to obtain the latest specifications and before placing your product order.

Copies of documents which have an order number and are referenced in this document, or other Intel literature may be obtained by calling 1-800-548-4725 or by visiting Intel's website at <http://www.intel.com>.

Intel and the Intel logo are trademarks or registered trademarks of Intel Corporation or its subsidiaries in the United States and other countries.

\*Other names and brands may be claimed as the property of others.

Copyright © 2005-2006, Intel Corporation. All Rights Reserved.



## Contents

---

<b>1.0</b>	<b>Introduction</b>	8
1.1	Product Overview	8
1.2	Related Hardware and Documents	10
<b>2.0</b>	<b>Ratings</b>	11
<b>3.0</b>	<b>Product Configurations and Specifications</b>	12
3.1	Product Configurations	13
3.1.1	Summary of Product Configurations	13
3.1.2	Intel® TXN132201013 / TXN132251013 Transceivers	15
3.1.3	Intel® TXN132271013 / TXN132241013 / TXN132282013 Transceivers	16
3.1.4	Intel® TXN132212013 Transceiver	18
3.1.5	Intel® TXN132204013 / TXN132274013 Transceiver	20
3.1.6	Intel® TXN132203015 / TXN132273015 Transceivers	21
3.1.7	Intel® TXN132204015 / TXN132254015 Transceivers	22
3.1.8	Intel® TXN132274015 / TXN132244015 / TXN132284015 Transceiver	23
3.1.9	Intel® TXN132214015 Transceiver	25
3.2	Timing	27
3.3	Control and Monitoring Functions	29
3.4	Data Input/Output Configuration	32
3.5	Pin Configuration	33
3.6	Input and Output Termination Description	34
3.7	Integrated Power Supply Sequencing	43
3.8	Mechanical Layout and Configuration	43
<b>4.0</b>	<b>Regulatory Compliance</b>	47
4.1	Electromagnetic Compatibility Compliance	47
4.2	Safety Compliance	48
4.3	Compliance with Restriction of Hazardous Substances	48
4.4	Product Certification Markings and Compliance Statements	49
<b>5.0</b>	<b>Ordering Information</b>	50
<b>6.0</b>	<b>Acronyms</b>	51

## Figures

1	Block Diagram	9
2	Intel® TXN13220/1/4/5/7/8 Transceiver – Demux Timing Diagram	27
3	Intel® TXN13220/1/4/5/7/8 Transceiver – Mux Timing Diagram	28
4	Heatsink "A" – 3" x 2.2" x 0.53"	43
5	Heatsink "B" – 3" x 2.2" x 0.63"	44
6	Heatsink "C" – 3" x 2.2" x 0.7"	45
7	Heatsink "D" – 3" x 2.2" x 0.53" Flat Top	46
8	Ordering Information	50



## Tables

1	Related Hardware and Documents .....	10
2	Absolute Maximum Ratings .....	11
3	Power Supply Requirements.....	11
4	Product Configurations .....	13
5	Intel® TXN132201013 / TXN132251013 (7 km SONET) Optical Specifications: Transmitter .....	15
6	Intel® TXN132201013 / TXN132251013 (7 km SONET) Optical Specifications: Link.....	15
7	Intel® TXN132201013 / TXN132251013 (7 km SONET) Optical Specifications: Receiver.....	15
8	Intel® TXN132271013 / TXN132241013 / TXN132282013 (7/10 km SONET/10 GbE) Optical Specifications: Transmitter.....	16
9	Intel® TXN132271013 / TXN132241013 / TXN132282013 (7/10 km SONET/10 GbE) Optical Specifications: Link .....	16
10	Intel® TXN132271013 / TXN132241013 / TXN132282013 (7/10 km SONET/10 GbE) Optical Specifications: Receiver .....	17
11	Intel® TXN132212013 (10 km 10GbE) Optical Specifications: Transmitter.....	18
12	Intel® TXN132212013 (10 km 10GbE) Optical Specifications: Link .....	18
13	Intel® TXN132212013 (10 km 10GbE) Optical Specifications: Receiver .....	19
14	Intel® TXN132204013/TXN132274013 (20 km SONET) Optical Specifications: Transmitter .....	20
15	Intel® TXN132204013/TXN132274013 (20 km SONET) Optical Specifications: Link.....	20
16	Intel® TXN132204013/TXN132274013 (20 km SONET) Optical Specifications: Receiver.....	20
17	Intel® TXN132203015 / TXN132273015 (25 km SONET) Optical Specifications: Transmitter.....	21
18	Intel® TXN132203015 / TXN132273015 (25 km SONET) Optical Specifications: Link .....	21
19	Intel® TXN132203015 / TXN132273015 (25 km SONET) Optical Specifications: Receiver .....	21
20	Intel® TXN132204015 / TXN132254015 (40 km SONET) Optical Specifications: Transmitter.....	22
21	Intel® TXN132204015 / TXN132254015 (40 km SONET) Optical Specifications: Link .....	22
22	Intel® TXN132204015 / TXN132254015 (40 km SONET) Optical Specifications: Receiver .....	22
23	Intel® TXN132274015 / TXN132244015 / TXN132284015 (40 km SONET/10 GbE) Optical Specifications: Transmitter.....	23
24	Intel® TXN132274015 / TXN132244015 / TXN132284015 (40 km SONET/10 GbE) Optical Specifications: Link .....	23
25	Intel® TXN132274015 / TXN132244015 / TXN132284015 (40 km SONET/10 GbE) Optical Specifications: Receiver .....	24
26	Intel® TXN132214015 (40 km 10 GbE) Optical Specifications: Transmitter .....	25
27	Intel® TXN132214015 (40 km SONET/10 GbE) Optical Specifications: Link.....	25
28	Intel® TXN132214015 (40 km SONET/10 GbE) Optical Specifications: Receiver.....	26
29	Intel® TXN13220/1/4/5/7/8 Transceiver – Demux Timing-Diagram Parameters .....	27
30	Intel® TXN13220/1/4/5/7/8 Transceiver – Mux Timing-Diagram Parameters .....	28
31	Analog Monitoring Signals and Characteristics .....	29
32	Digital Alarms .....	30
33	Digital Control Signals and I <sup>2</sup> C Bus .....	30
34	Truth Table for Transmit Rate Select (TxRATESEL[0:1]).....	31



35	Deserializer Logic Levels .....	31
36	Serializer Logic Levels.....	31
37	Data Input/Output Configuration .....	32
38	Pin Configuration .....	33
39	Input and Output Termination Description .....	34
40	Electromagnetic Compatibility Compliance .....	47
41	Safety Compliance .....	48
42	Product Certification Markings and Compliance Statements .....	49
43	Acronyms .....	51



## Revision History

---

Date	Revision	Description
October 2006	004	Changes for datasheet for Intel® TXN13220/1/4/5/7/8 10 Gbps, Multiple-Rate Optical Transceiver - Page 1 - Text changed Section 1.1, "Product Overview" on page 8 - Text changed Section 3.3, "Control and Monitoring Functions" on page 29 - Text changed Table 31, "Analog Monitoring Signals and Characteristics" on page 29 - Table changed Table 33, "Digital Control Signals and I <sup>2</sup> C Bus" on page 30 - Changed text for pin J29 Table 38, "Pin Configuration" on page 33 Changed text for pin J29 Table 39, "Input and Output Termination Description" on page 34 Changed text for pin J29 Section 4.0, "Regulatory Compliance" on page 47 - Text changed
October 2005	003	Third publication of datasheet for Intel® TXN13220/1/4/5/7/8 10 Gbps, Multiple-Rate Optical Transceiver
May 2003	002	Second publication of datasheet for Intel® TXN13220/1/4/5/7/8 10 Gbps, Multiple-Rate Optical Transceiver
October 2002	001	Initial release of datasheet for Intel® TXN13220/1/4/5/7/8 10 Gbps, Multiple-Rate Optical Transceiver





## 1.0 Introduction

This section discusses the following topics:

- Section 1.1, "Product Overview" on page 8
- Section 1.2, "Related Hardware and Documents" on page 10

### 1.1 Product Overview

The Intel® TXN13220/7/8 10 Gbps, Multiple-Rate Optical SerDes Transceiver with 16-Channel Multiplexer/Demultiplexer multi-rate line of 10 Gbps SerDes transceivers (called hereafter the TXN13220/1/4/5/7/8 Transceiver) is designed to provide a SONET/SDH, 10 GbE, or FEC interface between the physical layer and the electrical layer. The TXN13220/1/4/5/7/8 Transceiver comprises an optical transmitter and receiver pair, integrated with electrical multiplex and demultiplex functions.

As shown in the [Figure 1](#) block diagram, the TXN13220/1/4/5/7/8 Transceiver transmitter section multiplexes 16 channels from a differential LVDS parallel data bus into a 10 Gbps optical signal launched into a single-mode, optical-fiber pigtail. The transmitter contains a miniature packaged integrated driver with a semi-cooled 1310 nm DFB laser or a cooled 1550 nm EML.

The receiver operates over both the 1.3  $\mu\text{m}$  and 1.5  $\mu\text{m}$  bands and is compliant with SONET/SDH OC-192/STM-64 physical layer specifications and Draft 5.0 of IEEE\* 802.3ae 10GBASE-L and 10GBASE-E 10 GbE specifications. The rate at which the TXN13220/1/4/5/7/8 Transceiver operates is digitally selectable. The receiver includes a PIN photodiode and transimpedance amplifier, which operate over both the 1.3  $\mu\text{m}$  and 1.5  $\mu\text{m}$  bands.

The TXN13220/1/4/5/7/8 Transceiver is assembled in a multi-source agreement (MSA) compatible package with dimensions 3.0" L  $\times$  2.2" W  $\times$  0.53" H. The heatsink was designed for 55 °C ambient temperature/250 linear feet per minute airflow. Alternative heatsink options (for example, 0.63", 0.7" and 0.43" flat top) are also available upon request.

The LVDS interface connection is made using an MSA-compliant, 300-pin, Berg MEG-Array\* connector with standard pinout. Optical connections are made with standard SC-UPC or LC-UPC optical connectors. Other optical connection options may be available upon request.



Figure 1. Block Diagram

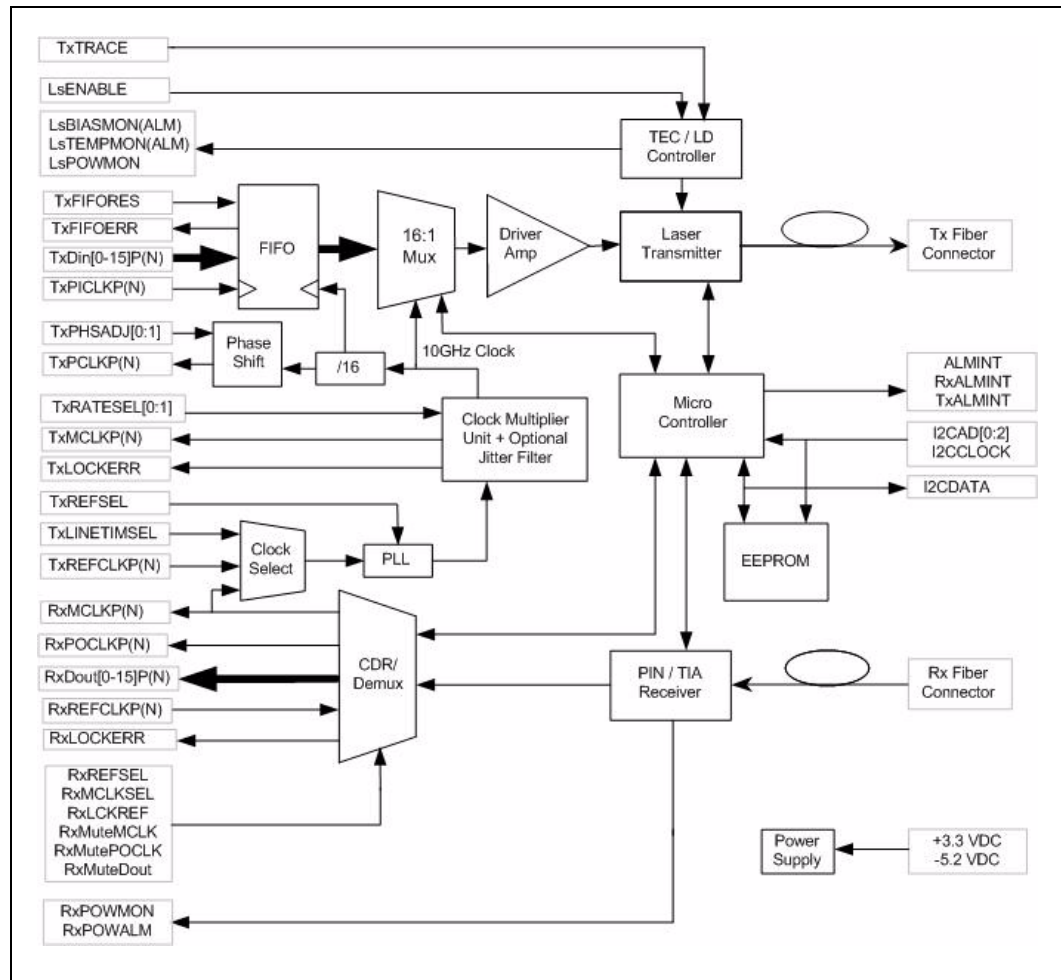



## 1.2 Related Hardware and Documents

Table 1 lists related hardware and documents. (To order any of the items, contact your Intel sales representative.)

**Table 1. Related Hardware and Documents**

Part Number	Description
TXNEL13000	Evaluation board: Provides looping back of the 16 received data output channels to 16-channel transmitter input
SCMEL13000	Schematic diagram of Intel® TXNEL13000 Evaluation Board
TXNEB13000	Evaluation board: SMA connectors give full access to all transmit input and receive output signals to allow separate test access to transmit and receive functions or external loopback with SMA cables.
SCMEB13000	Schematic diagram of Intel® TXNEB13000 Evaluation Board
TXNEB(L)APP	Intel® TXNEB(L)13000 Evaluation Board for Intel® TXN13220/7/8 Optical Transceiver Application Note (Intel order number 273938)
EEP13220APP	EEPROM/I <sup>2</sup> C Application note (Contact your Intel sales representative.)



## 2.0 Ratings

Table 2 lists the absolute maximum ratings for the TXN13220/1/4/5/7/8 Transceiver.

**Table 2. Absolute Maximum Ratings**

Parameter	Symbol	Min.	Max.	Unit
Case operating temperature range	$T_C$	-5	+70	°C
Case storage temperature range	$T_S$	-40	+85	°C
Positive supply voltage (+3.3 V)	$V_{3.3+}$	0	+3.6	V
Negative supply voltage (-5.2 V)	$V_-$	-6.0	+0.5	V
Relative humidity (non-condensing)	RH		85	%
Receiver input power			+5	dBm
Fiber bend radius		1.25 (31.8)		inches (mm)
Fiber Pigtail Length			$1 \pm 0.05$	m

Table 3 lists the power supply requirements.

**Table 3. Power Supply Requirements**

Parameter	Symbol	Min.	Nom.	Max.	Unit
Negative supply voltage (-5.2 V)	$V_-$	-5.45	-5.2	-4.95	V
Negative supply current drain (-5.2 V)	$I_-$		0.25		A
Positive supply voltage (+3.3 V)	$V_{3.3+}$	+3.15	+3.3	+3.45	V
Positive supply current drain (+3.3 V)	$I_{3.3+}$		1.0		A
Total Power Dissipation (1310 nm) <sup>†</sup>	$P_{diss}$		4	5.5	W
Total Power Dissipation (1550 nm) <sup>†</sup>	$P_{diss}$		4.5	7	W
<sup>†</sup> The 1310 nm power dissipation numbers are based on a 7 km link distance. The 1550 nm power dissipation numbers are based on a 40 km link distance.					



## 3.0 Product Configurations and Specifications

This section discusses the following topics:

- Section 3.1, "Product Configurations" on page 13
- Section 3.2, "Timing" on page 27
- Section 3.3, "Control and Monitoring Functions" on page 29
- Section 3.4, "Data Input/Output Configuration" on page 32
- Section 3.5, "Pin Configuration" on page 33
- Section 3.6, "Input and Output Termination Description" on page 34
- Section 3.7, "Integrated Power Supply Sequencing" on page 43
- Section 3.8, "Mechanical Layout and Configuration" on page 43



### 3.1 Product Configurations

This section discusses the following topics:

- Section 3.1.1, “Summary of Product Configurations” on page 13
- Section 3.1.2, “Intel® TXN132201013 / TXN132251013 Transceivers” on page 15
- Section 3.1.3, “Intel® TXN132271013 / TXN132241013 / TXN132282013 Transceivers” on page 16
- Section 3.1.4, “Intel® TXN132212013 Transceiver” on page 18
- Section 3.1.5, “Intel® TXN132204013 / TXN132274013 Transceiver” on page 20
- Section 3.1.6, “Intel® TXN132203015 / TXN132273015 Transceivers” on page 21
- Section 3.1.7, “Intel® TXN132204015 / TXN132254015 Transceivers” on page 22
- Section 3.1.8, “Intel® TXN132274015 / TXN132244015 / TXN132284015 Transceiver” on page 23
- Section 3.1.9, “Intel® TXN132214015 Transceiver” on page 25

#### 3.1.1 Summary of Product Configurations

The TXN13220/1/4/5/7/8 Transceiver family of SerDes Transceivers are available in several different versions, listed in Table 4.

**Table 4. Product Configurations (Sheet 1 of 2)**

Product Number	Rate (Gbps)	On-Board Jitter Filter?	Max. Reach (km)	Compliance Standard	Table Number for Tx, Rx, and Optical Link
TXN132201013	9.95	Single	7	GR-253 SR-1 and ITU G.691 I64.1	Table 5 Table 6 Table 7
TXN132241013	9.95 / 10.3	Dual	7/10	GR-253 SR-1, ITU G.691 I64.1, IEEE 802.3ae Draft 5.0 10GBASE-LR	Table 8 Table 9 Table 10
TXN132251013	9.95 / 10.7	Dual	7	GR-253 SR-1 and ITU G.691 I64.1, IEEE 802.3ae Draft 5.0 10GBASE-LW	Table 5 Table 6 Table 7
TXN132271013	9.95 / 10.3 / 10.71	No	7/10	GR-253 SR-1, ITU G.691 I64.1, IEEE 802.3ae Draft 5.0 10GBASE-LR	Table 8 Table 9 Table 10
TXN132212013	10.3	Single	10	IEEE802.3ae Draft 5.0 10GBASE-LR	Table 11 Table 12 Table 13
TXN132282013	9.95/ 10.3	Single at 9.95 Gbps	7/10	GR-253 SR-1, ITU G.691 I64.1, IEEE 802.3ae Draft 5.0 10GBASE-LR	Table 8 Table 9 Table 10
TXN132203015	9.95	Single	25	GR-253 SR-2 ITU G.691 I64.2	Table 17 Table 18 Table 19
TXN132273015	9.95 / 10.71	No	25	GR-253 SR-2 ITU G.691 I64.2	Table 17 Table 18 Table 19



**Table 4. Product Configurations (Sheet 2 of 2)**

Product Number	Rate (Gbps)	On-Board Jitter Filter?	Max. Reach (km)	Compliance Standard	Table Number for Tx, Rx, and Optical Link
TXN132204013	9.95	Single	20	GR-1377 IR-1, ITU G.691 S64.1	Table 14 Table 15 Table 16
TXN132274013	9.95 / 10.71	No	20	GR-1377 IR-1, ITU G.691 S64.1	Table 14 Table 15 Table 16
TXN132204015	9.95	Single	40	GR-253 IR-2 and ITU G.691 S-64.2b	Table 20 Table 21 Table 22
TXN132214015	10.3	Single	40	IEEE 802.3ae Draft 5.0 10GBASE-ER	Table 26 Table 27 Table 28
TXN132244015	9.95/10.3	Dual	40	GR-253 IR-2 and ITU G.691 S-64.2b, IEEE 802.3ae Draft 5.0 10GBASE-ER	Table 23 Table 24 Table 25
TXN132254015	9.95 / 10.7	Dual	40	GR-253 IR-2 and ITU G.691 S-64.2b	Table 20 Table 21 Table 22
TXN132274015	9.95 / 10.3 / 10.71	No	40	GR-253 IR-2 and ITU G.691 S-64.2b, IEEE 802.3ae Draft 5.0 10GBASE-ER	Table 23 Table 24 Table 25
TXN132284015	9.95 / 10.3	Single at 9.95 Gbps	40	GR-253 IR-1 and ITU G.691 I64.1, IEEE 802.3ae Draft 5.0 10GBASE-ER	Table 23 Table 24 Table 25



### 3.1.2 Intel® TXN132201013 / TXN132251013 Transceivers

The Intel® TXN132201013 and TXN132251013 SerDes Transceivers are designed for short-reach (up to 7 km) applications consistent with draft ITU-T G.691 recommendations for STM-64/I-64.1 and Telcordia\* GR-253 SR-1 optical interfaces. Table 5, Table 6, and Table 7 list the transmitter, link, and receiver specifications for the devices.

**Note:** Minimum and maximum values are specified over the case operating temperature range using a 2<sup>23</sup>-1 pseudo-random bit sequence (PRBS) signal. Typical values are measured at room temperature (25 °C), unless otherwise noted.

**Table 5. Intel® TXN132201013 / TXN132251013 (7 km SONET) Optical Specifications: Transmitter**

Parameter	Symbol	Min.	Max.	Unit
Average output power <sup>1</sup>	P <sub>O</sub>	-6	-1	dBm
Operating wavelength	λ	1,290	1,330	nm
Spectral width <sup>2</sup>	Δλ <sub>20</sub>		1	nm
Side mode suppression ratio <sup>3</sup>	SMSR	30		dB
Extinction ratio <sup>4</sup>	r <sub>e</sub>	6		dB
Eye mask of optical output	Compliant with Telcordia GR-253			
Jitter generation	Compliant with Telcordia GR-253			

**Notes:**

1. Output power definitions and measurements per ITU-T Recommendation G.957.
2. Full spectral width measured 20 dB down from the central wavelength peak, under fully modulated conditions.
3. Ratio of the average output power in the dominant longitudinal mode to the power in the most significant side mode, under fully modulated conditions.
4. Ratio of logic 1 output power to logic 0 output power, under fully modulated conditions.

**Table 6. Intel® TXN132201013 / TXN132251013 (7 km SONET) Optical Specifications: Link**

Parameter	Min.	Typ.	Max.	Unit
Attenuation	0		4	dB
Dispersion			6.6	ps/nm
Link distance		7		km
Link overall optical return loss			14	dB

**Table 7. Intel® TXN132201013 / TXN132251013 (7 km SONET) Optical Specifications: Receiver**

Parameter	Symbol	Min.	Typ.	Max.	Unit
Receiver sensitivity <sup>†</sup>	PR <sub>MIN</sub>		-14	-11	dBm
Receiver overload average power		-1			dBm
Optical path penalty				1	dB
Receiver reflectance				-27	dB

† PIN receiver at 1,310 nm, 1 × 10<sup>-12</sup> BER, 2<sup>23</sup>-1 PRBS



### 3.1.3 Intel® TXN132271013 / TXN132241013 / TXN132282013 Transceivers

The Intel® TXN132271013 / TXN132241013 / TXN132282013 SerDes Transceivers are designed for short-reach (up to 10 km) applications consistent with draft ITU-T G.691 recommendations for STM-64/I-64.1, Telcordia\* GR-253 SR-1 optical interfaces and IEEE\* 802.3ae D5.0 10GBASE-LR specifications. Table 8, Table 9, and Table 10 list the transmitter, link, and receiver specifications for the devices.

**Note:** Minimum and maximum values are specified over the case operating temperature range using a 2<sup>23</sup>-1 PRBS signal. Typical values are measured at room temperature (25 °C), unless otherwise noted.

**Table 8. Intel® TXN132271013 / TXN132241013 / TXN132282013 (7/10 km SONET/10 GbE) Optical Specifications: Transmitter**

Parameter	Symbol	Min.	Max.	Unit
Average output power	P <sub>O</sub>	-6	-1	dBm
Operating wavelength	λ	1,290	1,330	nm
Spectral width	Δλ <sub>20</sub>		1	nm
Side mode suppression ratio	SMSR	30		dB
Average launch power in OMA <sup>1</sup>	OMA	-5.2		dBm
Transmitter and dispersion penalty	TDP		3.2	dBm
Average launch power in OMA minus TDP	OMA-TDP	-6.2		dBm
Extinction ratio	r <sub>e</sub>	6		dB
RIN <sub>12</sub> OMA	RIN		-128	dB/Hz
Optical return loss tolerance	ORL		12	dB
Transmitter reflectance			-12	dB
Eye mask of optical output	Compliant with Telcordia* GR-253			
Jitter generation	Compliant with Telcordia* GR-253			

**Notes:**

1. Optical modulation amplitude, per triple trade-off curves for 10GBASE-LR/LW

**Table 9. Intel® TXN132271013 / TXN132241013 / TXN132282013 (7/10 km SONET/10 GbE) Optical Specifications: Link**

Parameter	Min.	Typ.	Max.	Unit
Attenuation	0		4	dB
Dispersion			6.6	ps/nm
Link distance		7	10	km
Channel insertion loss (10GBASE-L)			6.2	dB
Allocation for penalties (10GBASE-L)			3.2	dB
Link overall optical return loss			14	dB



**Table 10. Intel® TXN132271013 / TXN132241013 / TXN132282013 (7/ 10 km SONET/ 10 GbE) Optical Specifications: Receiver**

Parameter	Symbol	Min.	Typ.	Max.	Unit
Receiver sensitivity†	PR <sub>MIN</sub>		-14	-11	dBm
Stressed receiver sensitivity	PR <sub>SOMA</sub>			-10.3	dBm
Receiver overload average power		-1			dBm
Optical path penalty				1	dB
Receive electrical 3 dB upper cutoff frequency				12.3	GHz
Receiver reflectance				-27	dB

† PIN receiver at 1,310 nm, 1 × 10<sup>-12</sup> BER, 2<sup>-23</sup>-1 PRBS.



### 3.1.4 Intel® TXN132212013 Transceiver

The Intel® TXN132212013 SerDes Transceiver is designed for 10GBASE-LR (10 km) applications consistent with IEEE 802.3ae D5.0 10GBASE-LR specifications. Table 11, Table 12, and Table 13 list the transmitter, link, and receiver specifications for the device.

**Note:** Minimum and maximum values are specified over the case operating temperature range using a 2<sup>23</sup>-1 PRBS signal. Typical values are measured at room temperature (25 °C), unless otherwise noted.

**Table 11. Intel® TXN132212013 (10 km 10GbE) Optical Specifications: Transmitter**

Parameter	Symbol	Min.	Max.	Unit
Average output power	P <sub>O</sub>	-6	-1	dBm
Operating wavelength	λ	1,290	1,330	nm
Spectral width	Δλ <sub>20</sub>		1	nm
Side mode suppression ratio	SMSR	30		dB
Average launch power in OMA <sup>1</sup>	OMA	-5.2		dBm
Transmitter and dispersion penalty	TDP		3.2	dBm
Average launch power in OMA minus TDP	OMA-TDP	-6.2		dBm
Extinction ratio	r <sub>e</sub>	6		dB
RIN <sub>12</sub> OMA	RIN		-128	dB/Hz
Optical return loss tolerance	ORL		12	dB
Transmitter reflectance			-12	dB
Eye mask of optical output	Compliant with Telcordia GR-253			
Jitter generation	Compliant with Telcordia GR-253			

**Notes:**

- Optical modulation amplitude, per triple trade-off curves for 10GBASE-LR/LW.

**Table 12. Intel® TXN132212013 (10 km 10GbE) Optical Specifications: Link**

Parameter	Min.	Typ.	Max.	Unit
Attenuation	0		4	dB
Dispersion			6.6	ps/nm
Link distance		7	10	km
Channel insertion loss (10GBASE-L)			6.2	dB
Allocation for penalties (10GBASE-L)			3.2	dB
Link overall optical return loss			14	dB

**Table 13. Intel® TXN132212013 (10 km 10GbE) Optical Specifications: Receiver**

Parameter	Symbol	Min.	Typ.	Max.	Unit
Receiver sensitivity <sup>†</sup>	PR <sub>MIN</sub>		-14	-11	dBm
Stressed receiver sensitivity	PR <sub>SOMA</sub>			-10.3	dBm
Receiver overload average power		-1			dBm
Optical path penalty				1	dB
Receive electrical 3 dB upper cutoff frequency				12.3	GHz
Receiver reflectance				-27	dB

† PIN receiver at 1,310 nm,  $1 \times 10^{-12}$  BER,  $2^{23}-1$  PRBS.



### 3.1.5 Intel® TXN132204013 / TXN132274013 Transceiver

The Intel® TXN132204013 and TXN132274013 SerDes transceivers are designed for intermediate-reach (20 km) applications consistent with draft ITU-T G.691 recommendations for STM-64/S-64.1 and Telcordia\* GR-1377 IR-1 optical interfaces. Table 14, Table 15, and Table 16 list the transmitter, link, and receiver specifications for the devices.

*Note:* Minimum and maximum values are specified over the case operating temperature range using a 2<sup>23</sup>-1 PRBS signal. Typical values are measured at room temperature (25 °C), unless otherwise noted.

**Table 14. Intel® TXN132204013/TXN132274013 (20 km SONET) Optical Specifications: Transmitter**

Parameter	Symbol	Min.	Max.	Unit
Average output power	P <sub>O</sub>	+1	+5	dBm
Operating wavelength	λ	1290	1330	nm
Spectral width	Δλ <sub>20</sub>		1	nm
Side mode suppression ratio	SMSR	30		dB
Extinction ratio	r <sub>e</sub>	6		dB
Eye mask of optical output	Compliant with Telcordia GR-253			
Jitter generation	Compliant with Telcordia GR-253			

**Table 15. Intel® TXN132204013/TXN132274013 (20 km SONET) Optical Specifications: Link**

Parameter	Min.	Typ.	Max.	Unit
Attenuation	6		11	dB
Dispersion			70	ps/nm
Link distance		20		km
Link overall optical return loss	14			dB

**Table 16. Intel® TXN132204013/TXN132274013 (20 km SONET) Optical Specifications: Receiver**

Parameter	Symbol	Min.	Typ.	Max.	Unit
Receiver sensitivity <sup>†</sup>	PR <sub>MIN</sub>		-14	-11	dBm
Receiver overload average power		-1			dBm
Optical path penalty				1	dB
Receiver reflectance				-27	dB

<sup>†</sup> PIN receiver at 1,310 nm, 1 × 10<sup>-12</sup> BER, 2<sup>23</sup>-1 PRBS.



### 3.1.6 Intel® TXN132203015 / TXN132273015 Transceivers

The Intel® TXN132203015 and TXN132273015 SerDes Transceivers are designed for short-reach (25 km) applications consistent with draft ITU-T G.691 recommendations for I-64.2 and Telcordia GR-253 SR-2 optical interfaces. Table 17, Table 18, and Table 19 list the transmitter, link, and receiver specifications for the devices.

**Note:** Minimum and maximum values are specified over the case operating temperature range using a 2<sup>23</sup>-1 PRBS signal. Typical values are measured at room temperature (25 °C), unless otherwise noted.

**Table 17. Intel® TXN132203015 / TXN132273015 (25 km SONET) Optical Specifications: Transmitter**

Parameter	Symbol	Min.	Typ.	Max.	Unit
Average output power	P <sub>O</sub>	-5		-1	dBm
Operating wavelength	λ	1,530		1,565	nm
Spectral width	Δλ <sub>20</sub>		0.3	1	nm
Side mode suppression ratio	SMSR	30			dB
Extinction ratio	r <sub>e</sub>	8.2	10		dB
Eye mask of optical output	Compliant with Telcordia* GR-253				
Jitter generation	Compliant with Telcordia* GR-253				

**Table 18. Intel® TXN132203015 / TXN132273015 (25 km SONET) Optical Specifications: Link**

Parameter	Min.	Typ.	Max.	Unit
Attenuation	0		7	dB
Dispersion			500	ps/nm
Link distance		25		km
Link overall optical return loss			24	dB

**Table 19. Intel® TXN132203015 / TXN132273015 (25 km SONET) Optical Specifications: Receiver**

Parameter	Symbol	Min.	Typ.	Max.	Unit
Receiver sensitivity <sup>†</sup>	PR <sub>MIN</sub>		-17.5	-14	dBm
Receiver overload average power		-1			dBm
Optical path penalty				2	dB
Receiver reflectance				-27	dB

<sup>†</sup> PIN receiver at 1,550 nm, 1 × 10<sup>-12</sup> BER, 2<sup>23</sup>-1 PRBS.



### 3.1.7 Intel® TXN132204015 / TXN132254015 Transceivers

The Intel® TXN132204015 and TXN132254015 SerDes Transceivers are designed for intermediate-reach (40 km) applications consistent with draft ITU-T G.691 recommendations for STM-64/S-64.2b and Telcordia GR-253 IR-2 optical interfaces. Table 20, Table 21, and Table 22 list the transmitter, link, and receiver specifications for the devices.

**Note:** Minimum and maximum values are specified over the case operating temperature range using a  $2^{23}-1$  PRBS signal. Typical values are measured at room temperature (25 °C), unless otherwise noted.

**Table 20. Intel® TXN132204015 / TXN132254015 (40 km SONET) Optical Specifications: Transmitter**

Parameter	Symbol	Min.	Max.	Unit
Average output power	$P_O$	-1	2	dBm
Operating wavelength	$\lambda$	1,530	1,565	nm
Spectral width	$\Delta\lambda_{20}$		1	nm
Side mode suppression ratio	SMSR	30		dB
Extinction ratio	$r_e$	8.2		dB
Eye mask of optical output	Compliant with Telcordia* GR-253			
Jitter generation	Compliant with Telcordia* GR-253			

**Table 21. Intel® TXN132204015 / TXN132254015 (40 km SONET) Optical Specifications: Link**

Parameter	Min.	Typ.	Max.	Unit
Attenuation	3		11	dB
Dispersion			800	ps/nm
Link distance		40		km
Link overall optical return loss			24	dB

**Table 22. Intel® TXN132204015 / TXN132254015 (40 km SONET) Optical Specifications: Receiver**

Parameter	Symbol	Min.	Typ.	Max.	Unit
Receiver sensitivity <sup>†</sup>	$PR_{MIN}$		-16	-14	dBm
Receiver overload average power		-1			dBm
Optical path penalty				2	dB
Receiver reflectance				-27	dB

<sup>†</sup> PIN receiver at 1,550 nm,  $1 \times 10^{-12}$  BER,  $2^{23}-1$  PRBS.



### 3.1.8 Intel® TXN132274015 / TXN132244015 / TXN132284015 Transceiver

The Intel® TXN132274015 and TXN132284015 SerDes Transceivers are designed for intermediate-reach (40 km) applications consistent with draft ITU-T G.691 recommendations for STM-64/S-64.2b, Telcordia\* GR-253 IR-2 optical interfaces and IEEE\* 802.3ae D5.0 10GBASE-LR specifications. Table 23, Table 24, and Table 25 list the transmitter, link, and receiver specifications for the devices.

**Note:** Minimum and maximum values are specified over the case operating temperature range using a 2<sup>23</sup>-1 PRBS signal. Typical values are measured at room temperature (25 °C), unless otherwise noted.

**Table 23. Intel® TXN132274015 / TXN132244015 / TXN132284015 (40 km SONET/10 GbE) Optical Specifications: Transmitter**

Parameter	Symbol	Min.	Max.	Unit
Average output power	P <sub>O</sub>	-1	2	dBm
Operating wavelength	λ	1,530	1,565	nm
Average launch power in OMA	OMA	-1.7		dBm
Transmitter and dispersion penalty	TDP		3.0	dBm
Average launch power in OMA minus TDP	OMA-TDP	-2.1		dBm
Spectral width	Δλ <sub>20</sub>		1	nm
Side mode suppression ratio	SMSR	30		dB
Extinction ratio	r <sub>e</sub>	8.2		dB
RIN <sub>12</sub> OMA			-128	dB/Hz
Optical return loss tolerance			21	dB
Eye mask of optical output	Compliant with Telcordia* GR-253			
Jitter generation	Compliant with Telcordia* GR-253			

**Notes:**

- Optical Modulation Amplitude, per triple trade-off curves for 10GBASE-ER/EW

**Table 24. Intel® TXN132274015 / TXN132244015 / TXN132284015 (40 km SONET/10 GbE) Optical Specifications: Link**

Parameter	Min.	Typ.	Max.	Unit
Attenuation	3		11	dB
Dispersion			800	ps/nm
Link distance		40		km
Link overall optical return loss			24	dB
Operating distance (10GBASE-E)		30	40 <sup>1</sup>	km
Channel insertion loss (10GBASE-E)			10.9	dB
Allocation for Penalties (10GBASE-E)	3.6		4.1	dB

**Notes:**

- Links longer than 30 km are considered engineered links



**Table 25. Intel® TXN132274015 / TXN132244015 / TXN132284015 (40 km SONET/10 GbE) Optical Specifications: Receiver**

Parameter	Symbol	Min.	Typ.	Max.	Unit
Receiver sensitivity†	PR <sub>MIN</sub>		-16	-14	dBm
Stressed receiver sensitivity	PR <sub>SOMA</sub>			-11.3	dBm
Receiver overload average power		-1			dBm
Optical path penalty				2	dB
Receive electrical 3dB upper cutoff frequency				12.3	GHz
Receiver reflectance				-27	dB

† PIN receiver at 1,550 nm,  $1 \times 10^{-12}$  BER,  $2^{23}-1$  PRBS.



### 3.1.9 Intel® TXN132214015 Transceiver

The Intel® TXN132214015 SerDes Transceiver is designed for 10GBASE-ER (40 km) applications consistent with IEEE 802.3ae D5.0 10GBASE-ER specifications. Table 26, Table 27, and Table 28 list the transmitter, link, and receiver specifications for the device.

**Note:** Minimum and maximum values are specified over the case operating temperature range using a 2<sup>23</sup>-1 PRBS signal. Typical values are measured at room temperature (25 °C), unless otherwise noted.

**Table 26. Intel® TXN132214015 (40 km 10 GbE) Optical Specifications: Transmitter**

Parameter	Symbol	Min.	Typ.	Max.	Unit
Average output power	P <sub>O</sub>	-1		2	dBm
Operating wavelength	λ	1,530		1,565	nm
Average launch power in OMA	OMA	-1.7			dBm
Transmitter and dispersion penalty	TDP			3.0	dBm
Average launch power in OMA minus TDP	OMA-TDP	-2.1			dBm
Spectral width	Δλ <sub>20</sub>			1	nm
Side mode suppression ratio	SMSR	30			dB
Extinction ratio	r <sub>e</sub>	8.2	10		dB
RIN <sub>OMA</sub>				-128	dB/Hz
Optical return loss tolerance				21	dB
Eye mask of optical output	Compliant with Telcordia GR-253				
Jitter generation	Compliant with Telcordia GR-253				

**Notes:**

- Optical Modulation Amplitude, per triple trade-off curves for 10GBASE-ER/EW

**Table 27. Intel® TXN132214015 (40 km SONET/10 GbE) Optical Specifications: Link**

Parameter	Min.	Typ.	Max.	Unit
Attenuation	3		11	dB
Dispersion			800	ps/nm
Link distance		40		km
Link overall optical return loss			24	dB
Operating distance (10GBASE-E)		30	40 <sup>1</sup>	km
Channel insertion loss (10GBASE-E)			10.9	dB
Allocation for Penalties (10GBASE-E)	3.6		4.1	dB

**Notes:**

- Links longer than 30 km are considered engineered links.



**Table 28. Intel® TXN132214015 (40 km SONET/ 10 GbE) Optical Specifications: Receiver**

Parameter	Symbol	Min.	Typ.	Max.	Unit
Receiver sensitivity†	PR <sub>MIN</sub>		-17.5	-14	dBm
Stressed receiver sensitivity	PR <sub>SOMA</sub>			-11.3	dBm
Receiver overload average power		-1			dBm
Optical path penalty				2	dB
Receive electrical 3dB upper cutoff frequency				12.3	GHz
Receiver reflectance				-27	dB

† PIN receiver at 1,550 nm, 1 × 10<sup>-12</sup> BER, 2<sup>23</sup>-1 PRBS.



### 3.2 Timing

The TXN13220/1/4/5/7/8 Transceiver transceiver timing is compliant with Optical Internetworking Forum SFI-4 recommendations for the common electrical interface between framers and serializer/deserializer parts for STS-192/STM-64 interfaces.

Figure 2 is a timing diagram for the TXN13220/1/4/5/7/8 Transceiver on the optical receiver side, (that is, the output of the transceiver demux). Table 29 lists the timing diagram parameters.

**Figure 2. Intel® TXN13220/1/4/5/7/8 Transceiver – Demux Timing Diagram**

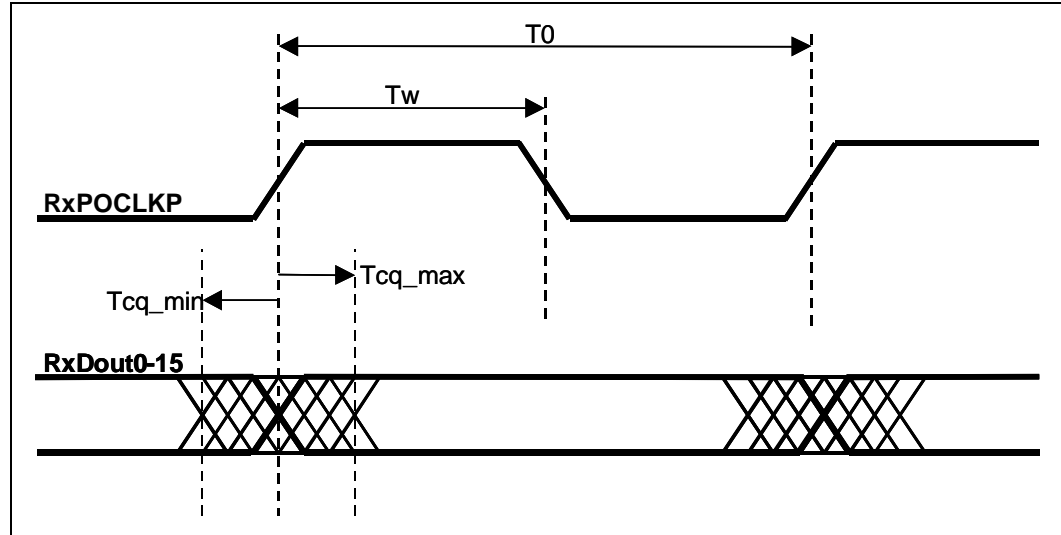

**Table 29. Intel® TXN13220/1/4/5/7/8 Transceiver – Demux Timing-Diagram Parameters**

Parameter	Description	Value
$T_0$	Clock period at 622 Mbps (SONET rate) Clock period at 645 Mbps (10 GbE rate) Clock period at 669 Mbps (SONET + FEC rate)	1.608 ns 1.55151 ns 1.49477 ns
$T_w/T_0$	Duty Cycle = width of high clock pulse divided by clock period.	$0.45 < T_w/T_0 < 0.55$
$T_r, T_f$	Rise and fall times (20% to 80%)	100 to 250 ps
$T_{cq\_min}, T_{cq\_max}$	Minimum and maximum clock to data transition skew.	200 ps, 200 ps

Figure 3 is a timing diagram for the TXN13220/1/4/5/7/8 Transceiver on the optical transmit side (that is, the input of transponder mux). Table 30 lists the timing diagram parameters.

Figure 3. Intel® TXN13220/1/4/5/7/8 Transceiver – Mux Timing Diagram

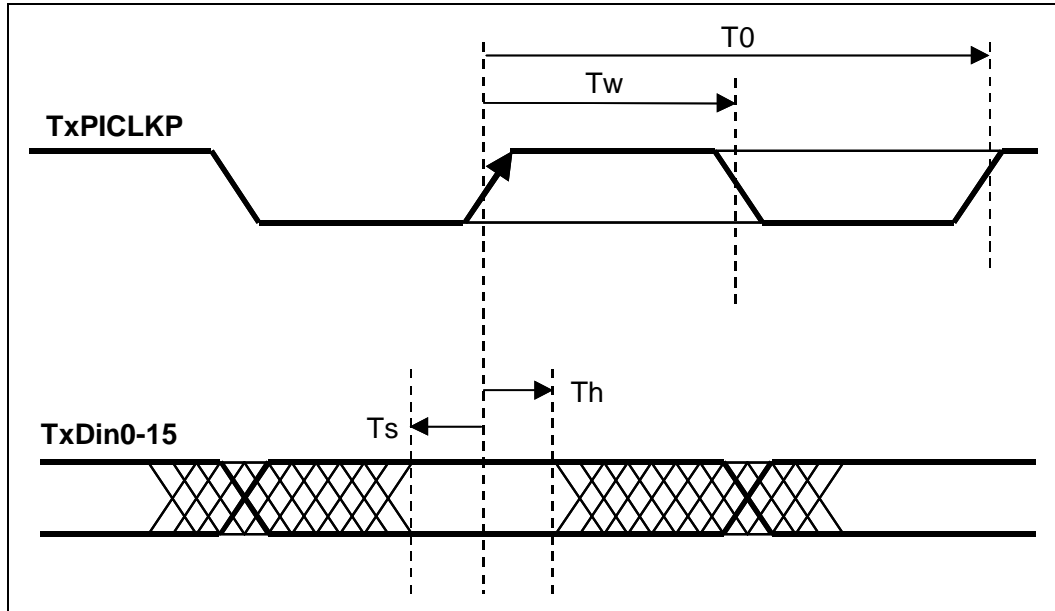

Table 30. Intel® TXN13220/1/4/5/7/8 Transceiver – Mux Timing-Diagram Parameters

Parameter	Description	Value
T0	Clock period at 622 Mbps (SONET rate) Clock period at 645 Mbps (10 GbE rate) Clock period at 669 Mbps (SONET + FEC rate)	1.608 ns 1.55151 ns 1.49477 ns
Tw/T0	Duty Cycle = width of high clock pulse divided by clock period.	0.40 < Tw/T0 < 0.60
Tr, Tf	Rise and fall times (20% to 80%)	100 to 300 ps
Ts, Th	Maximum data setup and hold times required relative to positive clock edge.	300 ps



### 3.3 Control and Monitoring Functions

The TXN13220/1/4/5/7/8 Transceiver line of transceivers provides a combination of analog and digital control and monitoring functions as listed in [Table 31](#), [Table 32](#), and [Table 33](#).

**Note:**

- Active signal monitoring using an on-board microprocessor through the I<sup>2</sup>C bus is available for this optical transceiver. For more information, consult the EEP13220APP application note.
- A fixed content EEPROM, containing many transceiver parameters (for example, calibration data and serial number), can also be accessed through the I<sup>2</sup>C bus by using a different address. For details, see the EEP13220APP document referenced in [Section 1.2, "Related Hardware and Documents"](#) on [page 10](#).

**Table 31. Analog Monitoring Signals and Characteristics**

Function	Pin Name	Pin Number	Signal	Range
Input optical power	RxPOWMON	F3	Output voltage proportional to average received optical power Referenced to 0 V with typical slope of 1 V/mW (minimum 0.8V/mW and maximum 1.26 V/mW)	Voltage – 0 to 2 V Current – ± 100 µA
Laser bias monitor	LsBIASMON	F18	Output proportional to transmit laser DC bias $V = 20 * (I - \text{Offset})$ mV where I = laser bias mA.	Voltage – 0 to 2 V Current – ± 100 µA
Laser temperature monitor	LsTEMPMON	D21	Output proportional to transmit laser temperature $V = 0.764 * e^{3887 * (1/T - 1/298)}$ volts, where T is temperature in Kelvins. Nominally 0.4 to 0.6 V under normal operation.	Voltage – 0 to 3.3 V Current – ± 100 µA
Laser power monitor	LsPOWMON	D18	Output proportional to transmit laser average output power. Nominal value of 0.5 V should remain constant due to high gain power control loop.	Voltage – 0 to 2 V Current – ± 100 µA



**Table 32. Digital Alarms**

Function	Pin Name	Pin Number	Logic	Logic 0	Logic 1	Condition
Transmitter PLL lock error	TxLOCKERR	B30	LVTTTL	Out of lock	In lock	Out of lock when on chip VCO not locked to TxREFCLK
Receiver PLL lock detect	RxLOCKERR	B15	LVTTTL	Out of lock	In lock	Low if CDR is unable to recover valid clock from receive optical input signal.
Receiver loss of average power alarm	RxPOWALM	F6	LVTTTL	No input signal	Input signal present	Logic high for signal above receiver sensitivity. Low for signal $\leq -30$ dBm.
Laser bias alarm	LsBIASALM	F24	LVTTTL	Alarm	Normal	Alarm if laser bias $>100$ mA
Laser temp alarm	LsTEMPALM	F27	LVTTTL	Alarm	Normal	Alarm if laser temperature deviates more than 2.5 degrees from initial set point
Receiver alarm interrupt	RxALMINT	J14	LVTTTL	Alarm	Normal	Electrical OR of all receive alarms
Alarm interrupt	ALMINT	H15	LVTTTL	Alarm	Normal	Electrical OR of all receive and transmit alarms
Transmitter alarm interrupt	TxALMINT	J16	LVTTTL	Alarm	Normal	Electrical OR of all transmit alarms

**Table 33. Digital Control Signals and I<sup>2</sup>C Bus**

Function	Pin Name	Pin Number	Logic	Logic 0	Logic 1
Transmitter laser enable in	LsENABLE	F21	LVTTTL	Enabled	Disabled
Selects 1/64 line bit rate or 1/16 line bit rate-MHz reference clock for mux - TxREFCLK	TxREFSEL	F30	LVTTTL	1/64 line bit rate MHz	1/16 line bit rate MHz
Selects 1/64 line bit rate or 1/16 line bit rate of reference clock for demux - RxREFCLK	RxREFSEL	F15	LVTTTL	1/64 line bit rate	1/16 line bit rate
Selects 1/64 line bit rate or 1/16 line bit rate of demux monitor clock out - RxMCLK	RxMCLKSEL	B12	LVTTTL	1/64 line bit rate	1/16 line bit rate
Line timing mode internally loops recovered receive clock (RxPOCLK) back to TxREFCLK	TxLINETIMSEL	H30	LVTTTL	Line Timing	TxREFCLK Timing
Receive lock to reference forces the VCO in the receiver clock recovery circuit to lock to RxREFCLK	RxLCKREF	B9	LVTTTL	Lock to ref	Normal
Mutes the data outputs of the demux	RxMuteDout	B6	LVTTTL	Mutes the RxDout [0:15]	Normal
Mutes the RxPOCLK	RxMutePOCLK	K9	LVTTTL	Mutes the RxPOCLK	Normal
I <sup>2</sup> C Clock Input	I2CCLOCK	K15	LVTTTL		
I <sup>2</sup> C Data <sup>†</sup>	I2CDATA	K18	LVTTTL		
TxRATESEL1	TxRateSel1	J21	LVTTTL	See Table 34	See Table 34
TxRATESEL0	TxRateSel0	K21	LVTTTL	See Table 34	See Table 34

<sup>†</sup> See the application note for details regarding the contents of the EEPROM.

**Table 34. Truth Table for Transmit Rate Select (TxRATESEL[0:1])**

TxRATESEL1	TxRATESEL0	Rate Selected
0	0	10 GbE rate of 10.3 Gbps selected
0	1	Jitter-filter disable/enable from default
1	0	FEC rate of 10.7 Gbps selected
1	1	SONET rate of 9.85 Gbps selected

**Table 35. Deserializer Logic Levels**

Symbol	LVDS/ LVTTTL	Characteristic	Min.	Typ.	Max.	Units
Vod	LVDS	LVDS output differential voltage		400		mV
Vocm	LVDS	LVDS output common mode voltage		1.2		V
Vih	LVTTTL	LVTTTL input high voltage	2		5	V
Iih	LVTTTL	Input high current	-500		0	μA
Vil	LVTTTL	Input low voltage	0		0.8	V
Iil	LVTTTL	Input low current	0		400	μA

**Table 36. Serializer Logic Levels**

Symbol	LVDS/ LVTTTL	Characteristic	Min.	Typ.	Max.	Units
Vod	LVDS	LVDS output differential voltage		400		mV
Vocm	LVDS	LVDS output common mode voltage		1.2		V
Vivr	LVDS	LVDS input voltage range	0.8		2.4	V
Rin	LVDS	LVDS input termination resistor	80	100	120	Ω
Vih	LVTTTL	LVDS input high voltage	2		5	V
Iih	LVTTTL	Input high current	-500		0	μA
Vil	LVTTTL	Input high voltage	0		0.8	V
Iil	LVTTTL	Input low current	0		400	μA
Voh	LVTTTL	LVTTTL output voltage high	2.4			V
Vol	LVTTTL	Output voltage low			0.4	V



### 3.4 Data Input/Output Configuration

The TXN13220/1/4/5/7/8 Transceiver product line of transceivers fully compliant with OIF standards for LVDS I/O data format.

Bit ordering is compliant with SONET requirements, whereby the most-significant bit is transmitted first. SONET bit ordering is maintained for all data rates.

Table 37 lists the I/O configuration.

**Table 37. Data Input/Output Configuration**

Pin Name	In/Out	Description	Logic
TxDin0P(N), ..., TxDin15P(N)	In	Transmitter (1/16 line bit rate) data input, differential pairs.	LVDS, internally 100 $\Omega$ terminated
TxPICKLP(N)	In	Transmitter (1/16 line bit rate) input clock, differential pair, aligned with input data	LVDS, internally 100 $\Omega$ terminated
TxREFCLKP(N)	In	Transmitter reference clock input, differential pair. Selectable between 1/64 line bit rate and 1/16 line bit rate MHz using TxREFSEL	LVPECL, AC Coupled
TxPCLKP(N)	Out	Transmitter (1/16 line bit rate) reference clock output, differential pair	LVDS
RxDout0P(N), ..., RxDout15P(N)	Out	Receiver (1/16 line bit rate) data output, differential pairs	LVDS
RxREFCLKP(N)	In	Receiver reference clock input, differential pair. Selectable between 1/64 line bit rate and 1/16 line bit rate MHz using RxREFSEL	LVPECL, AC Coupled
RxPOCLKP(N)	Out	Receiver (1/16 line bit rate) MHz clock output, differential pairs, aligned with output data	LVDS
RxMCLKP(N)	Out	Demultiplexer monitor clock output. Selectable between 1/64 line bit rate and 1/16 line bit rate MHz by using RxMCLKSEL	LVDS
TxMCLKP(N)	Out	Multiplexer monitor clock output: 1/64 line bit rate MHz	LVDS



### 3.5 Pin Configuration

Table 38 lists the pin configuration.

**Table 38. Pin Configuration**

Pin #	A	B	C	D	E	F	G	H	J	K
1	RxDout0P	Digital GND	RxDout4P	Digital GND	RxDout8P	NIC	RxDout12P	Frame GND	NIC	NIC
2	RxDout0N	Digital GND	RxDout4N	Digital GND	RxDout8N	NIC	RxDout12N	Frame GND	NIC	NIC
3	Digital GND	RxDTV	Digital GND	I2CAD0	Digital GND	RxPOWMON	Digital GND	NIC	NIC	NIC
4	RxDout1P	Digital GND	RxDout5P	Digital GND	RxDout9P	+ 3.3 VDigital	RxDout13P	Frame GND	NIC	+ 3.3 VAnalog
5	RxDout1N	Digital GND	RxDout5N	Digital GND	RxDout9N	+ 3.3 VDigital	RxDout13N	Frame GND	NIC	+ 3.3 VAnalog
6	Digital GND	RxMuteDout	Digital GND	I2CAD1	Digital GND	RxPOWALM	Digital GND	NIC	NIC	NIC
7	RxDout2P	Digital GND	RxDout6P	Digital GND	RxDout10P	+ 3.3 VDigital	RxDout14P	Analog GND	NIC	NIC
8	RxDout2N	Digital GND	RxDout6N	Digital GND	RxDout10N	+ 3.3 VDigital	RxDout14N	Analog GND	NIC	NIC
9	Digital GND	RxLCKREF	Digital GND	I2CAD2	Digital GND	NIC	Digital GND	NIC	NIC	RxMutePOCLK
10	RxDout3P	Digital GND	RxDout7P	Digital GND	RxDout11P	- 5.2 VDigital	RxDout15P	Analog GND	NIC	- 5.2 VAnalog
11	RxDout3N	Digital GND	RxDout7N	Digital GND	RxDout11N	- 5.2 VDigital	RxDout15N	Analog GND	NIC	- 5.2 VAnalog
12	Digital GND	RxMCLKSEL	Digital GND	NIC	Digital GND	NIC	Digital GND	NIC	NIC	RxMuteMCLK
13	RxREFCLKP	Digital GND	RxMCLKP	Digital GND	RxPOCLKP	- 5.2 VDigital	NIC	Analog GND	NIC	- 5.2 VAnalog
14	RxREFCLKN	Digital GND	RxMCLKN	Digital GND	RxPOCLKN	- 5.2 VDigital	NIC	Analog GND	RxALM INT	- 5.2 VAnalog
15	Digital GND	RxLOCKERR	Digital GND	NIC	Digital GND	RxREFSEL	Digital GND	ALMINT	NIC	I2CCLOCK
16	TxDin0P	Digital GND	TxDin4P	Digital GND	TxDin8P	NIC	TxDin12P	Analog GND	TxALM INT	NIC
17	TxDin0N	Digital GND	TxDin4N	Digital GND	TxDin8N	NIC	TxDin12N	Analog GND	NIC	NIC
18	Digital GND	NIC	Digital GND	LsPOWMON	Digital GND	LsBIASMON	Digital GND	NIC	NIC	I2CDATA
19	TxDin1P	Digital GND	TxDin5P	Digital GND	TxDin9P	+ 3.3 VDigital	TxDin13P	Analog GND	NIC	+ 3.3 VAnalog
20	TxDin1N	Digital GND	TxDin5N	Digital GND	TxDin9N	+ 3.3 VDigital	TxDin13N	Analog GND	NIC	+ 3.3 VAnalog
21	Digital GND	NIC	Digital GND	LsTEMPMON	Digital GND	LsENABLE	Digital GND	NIC	TxRateSel1	TxRateSel0
22	TxDin2P	Digital GND	TxDin6P	Digital GND	TxDin10P	+ 3.3 VDigital	TxDin14P	Analog GND	NIC	+ 3.3 VAnalog
23	TxDin2N	Digital GND	TxDin6N	Digital GND	TxDin10N	+ 3.3 VDigital	TxDin14N	Analog GND	NIC	+ 3.3 VAnalog
24	Digital GND	NIC	Digital GND	TxPHSADJ0	Digital GND	LsBIASALM	Digital GND	NIC	NIC	TxRESET
25	TxDin3P	Digital GND	TxDin7P	Digital GND	TxDin11P	- 5.2 VDigital	TxDin15P	Frame GND	NIC	- 5.2 VAnalog
26	TxDin3N	Digital GND	TxDin7N	Digital GND	TxDin11N	- 5.2 VDigital	TxDin15N	Frame GND	NIC	- 5.2 VAnalog
27	Digital GND	NIC	Digital GND	TxPHSADJ1	Digital GND	LsTEMPALM	Digital GND	NIC	NIC	TxFIFORES
28	TxREFCLKP	Digital GND	TxMCLKP	Digital GND	TxPCLKP	- 5.2 VDigital	TxPICKLP	Frame GND	NIC	- 5.2 VAnalog
29	TxREFCLKN	Digital GND	TxMCLKN	Digital GND	TxPCLKN	- 5.2 VDigital	TxPICKLN	Frame GND	NIC	- 5.2 VAnalog
30	Digital GND	TxLOCKERR	Digital GND	LsPOWALM	Digital GND	TxREFSEL	Digital GND	TxLINTIMSEL	NIC	TxFIFOERR

**Note:** NIC = Transceiver has no internal connection to this pin.



### 3.6 Input and Output Termination Description

**Table 39. Input and Output Termination Description (Sheet 1 of 9)**

Pin Number	Symbol	I/O	Logic	Description
A1	RxDout0P	Out	LVDS	Receiver ( $1/16$ line bit rate) data output, differential pairs.
A2	RxDout0N	Out	LVDS	Receiver ( $1/16$ line bit rate) data output, differential pairs.
A3	Digital GND	In	Supply	Digital Ground
A4	RxDout1P	Out	LVDS	Receiver ( $1/16$ line bit rate) data output, differential pairs.
A5	RxDout1N	Out	LVDS	Receiver ( $1/16$ line bit rate) data output, differential pairs.
A6	Digital GND	In	Supply	Digital Ground
A7	RxDout2P	Out	LVDS	Receiver ( $1/16$ line bit rate) data output, differential pairs.
A8	RxDout2N	Out	LVDS	Receiver ( $1/16$ line bit rate) data output, differential pairs.
A9	Digital GND	In	Supply	Digital Ground
A10	RxDout3P	Out	LVDS	Receiver ( $1/16$ line bit rate) data output, differential pairs.
A11	RxDout3N	Out	LVDS	Receiver ( $1/16$ line bit rate) data output, differential pairs.
A12	Digital GND	In	Supply	Digital Ground
A13	RxREFCLKP	In	LVPECL, AC Coupled	Receiver reference clock input, differential pair, selectable between $1/64$ or $1/16$ line bit rate MHz by RxREFSEL (F15).
A14	RxREFCLKN	In	LVPECL, AC Coupled	Receiver reference clock input, differential pair, selectable $1/64$ or $1/16$ line bit rate MHz by RxREFSEL (F15).
A15	Digital GND	In	Supply	Digital Ground
A16	TxDin0P	In	LVDS, internally 100 $\Omega$ terminated	Transmitter ( $1/16$ line bit rate) data input, differential pairs.
A17	TxDin0N	In	LVDS, internally 100 $\Omega$ terminated	Transmitter ( $1/16$ line bit rate) data input, differential pairs.
A18	Digital GND	In	Supply	Digital Ground
A19	TxDin1P	In	LVDS, internally 100 $\Omega$ terminated	Transmitter ( $1/16$ line bit rate) data input, differential pairs.
A20	TxDin1N	In	LVDS, internally 100 $\Omega$ terminated	Transmitter ( $1/16$ line bit rate) data input, differential pairs.
A21	Digital GND	In	Supply	Digital Ground
A22	TxDin2P	In	LVDS, internally 100 $\Omega$ terminated	Transmitter ( $1/16$ line bit rate) data input, differential pairs.
A23	TxDin2N	In	LVDS, internally 100 $\Omega$ terminated	Transmitter ( $1/16$ line bit rate) data input, differential pairs.
A24	Digital GND	In	Supply	Digital Ground
A25	TxDin3P	In	LVDS, internally 100 $\Omega$ terminated	Transmitter ( $1/16$ line bit rate) data input, differential pairs.
A26	TxDin3N	In	LVDS, internally 100 $\Omega$ terminated	Transmitter ( $1/16$ line bit rate) data input, differential pairs.
A27	Digital GND	In	Supply	Digital Ground
A28	TxREFCLKP	In	LVPECL, AC Coupled	Transmitter reference clock in, differential pair, selectable between $1/64$ or $1/16$ line bit rate MHz using TxREFSEL (F30).
A29	TxREFCLKN	In	LVPECL, AC Coupled	Transmitter reference clock input, differential pair, selectable between $1/64$ or $1/16$ line bit rate MHz using TxREFSEL (F30).
A30	Digital GND	In	Supply	Digital Ground

**Table 39. Input and Output Termination Description (Sheet 2 of 9)**

Pin Number	Symbol	I/O	Logic	Description
B1	Digital GND	In	Supply	Digital Ground
B2	Digital GND	In	Supply	Digital Ground
B3	NIC	N/A	N/A	No Internal Connection
B4	Digital GND	In	Supply	Digital Ground
B5	Digital GND	In	Supply	Digital Ground
B6	RxMuteDout	In	LVTTTL	Mutes the data outputs of the demux.
B7	Digital GND	In	Supply	Digital Ground
B8	Digital GND	In	Supply	Digital Ground
B9	RxLCKREF	In	LVTTTL Logic 0: Lock to ref Logic 1: Normal	Receive lock to reference forces the VCO in the receiver clock recovery circuit to lock to RxREFCLK instead of incoming signal.
B10	Digital GND	In	Supply	Digital Ground
B11	Digital GND	In	Supply	Digital Ground
B12	RxMCLKSEL	In	LVTTTL	Selects RxMCLK—either $1/64$ or $1/16$ line bit rate MHz.
B13	Digital GND	In	Supply	Digital Ground
B14	Digital GND	In	Supply	Digital Ground
B15	RxLOCKERR	Out	LVTTTL Logic 0: Out of lock Logic 1: In lock	Receiver PLL lock detect. Low if CDR not able to recover valid clock from receive optical input.
B16	Digital GND	In	Supply	Digital Ground
B17	Digital GND	In	Supply	Digital Ground
B18	NIC	N/A	N/A	No Internal Connection
B19	Digital GND	In	Supply	Digital Ground
B20	Digital GND	In	Supply	Digital Ground
B21	NIC	N/A	N/A	No Internal Connection
B22	Digital GND	In	Supply	Digital Ground
B23	Digital GND	In	Supply	Digital Ground
B24	NIC	N/A	N/A	No Internal Connection
B25	Digital GND	In	Supply	Digital Ground
B26	Digital GND	In	Supply	Digital Ground
B27	NIC	N/A	N/A	No Internal Connection
B28	Digital GND	In	Supply	Digital Ground
B29	Digital GND	In	Supply	Digital Ground
B30	TxLOCKERR	Out	LVTTTL Logic 0: Out of lock Logic 1: In lock	Transmitter PLL lock error. Out of lock when on chip VCO not locked to TxREFCLK.
C1	RxDout4P	Out	LVDS	Receiver ( $1/16$ line bit rate) data output, differential pairs.
C2	RxDout4N	Out	LVDS	Receiver ( $1/16$ line bit rate) data output, differential pairs.
C3	Digital GND	In	Supply	Digital Ground
C4	RxDout5P	Out	LVDS	Receiver ( $1/16$ line bit rate) data output, differential pairs.
C5	RxDout5N	Out	LVDS	Receiver ( $1/16$ line bit rate) data output, differential pairs.



**Table 39. Input and Output Termination Description (Sheet 3 of 9)**

Pin Number	Symbol	I/O	Logic	Description
C6	Digital GND	In	Supply	Digital Ground
C7	RxDout6P	Out	LVDS	Receiver ( $1/16$ line bit rate) data output, differential pairs.
C8	RxDout6N	Out	LVDS	Receiver ( $1/16$ line bit rate) data output, differential pairs.
C9	Digital GND	In	Supply	Digital Ground
C10	RxDout7P	Out	LVDS	Receiver ( $1/16$ line bit rate) data output, differential pairs.
C11	RxDout7N	Out	LVDS	Receiver ( $1/16$ line bit rate) data output, differential pairs.
C12	Digital GND	In	Supply	Digital Ground
C13	RxMCLKP	Out	LVDS	Demultiplexer monitor clock output, differential pair, selectable between $1/64$ or $1/16$ line bit rate MHz by RxMCLKSEL (B12).
C14	RxMCLKN	Out	LVDS	Demultiplexer monitor clock output, differential pair, selectable between $1/64$ or $1/16$ line bit rate MHz by RxMCLKSEL (B12).
C15	Digital GND	In	Supply	Digital Ground
C16	TxDin4P	In	LVDS, internally 100 $\Omega$ terminated	Transmitter ( $1/16$ line bit rate) data input, differential pairs.
C17	TxDin4N	In	LVDS, internally 100 $\Omega$ terminated	Transmitter ( $1/16$ line bit rate) data input, differential pairs.
C18	Digital GND	In	Supply	Digital Ground
C19	TxDin5P	In	LVDS, internally 100 $\Omega$ terminated	Transmitter ( $1/16$ line bit rate) data input, differential pairs.
C20	TxDin5N	In	LVDS, internally 100 $\Omega$ terminated	Transmitter ( $1/16$ line bit rate) data input, differential pairs.
C21	Digital GND	In	Supply	Digital Ground
C22	TxDin6P	In	LVDS, internally 100 $\Omega$ terminated	Transmitter ( $1/16$ line bit rate) data input, differential pairs.
C23	TxDin6N	In	LVDS, internally 100 $\Omega$ terminated	Transmitter ( $1/16$ line bit rate) data input, differential pairs.
C24	Digital GND	In	Supply	Digital Ground
C25	TxDin7P	In	LVDS, internally 100 $\Omega$ terminated	Transmitter ( $1/16$ line bit rate) data input, differential pairs.
C26	TxDin7N	In	LVDS, internally 100 $\Omega$ terminated	Transmitter ( $1/16$ line bit rate) data input, differential pairs.
C27	Digital GND	In	Supply	Digital Ground
C28	TxMCLKP	Out	LVDS	Multiplexer monitor clock output, differential pair, $1/64$ line bit rate.
C29	TxMCLKN	Out	LVDS	Multiplexer monitor clock output, differential pair, $1/64$ line bit rate.
C30	Digital GND	In	Supply	Digital Ground
D1	Digital GND	In	Supply	Digital Ground
D2	Digital GND	In	Supply	Digital Ground
D3	I2CAD0	In	LVTTTL	I <sup>2</sup> C address input for module addressing (LSB).
D4	Digital GND	In	Supply	Digital Ground
D5	Digital GND	In	Supply	Digital Ground
D6	I2CAD1	In	LVTTTL	I <sup>2</sup> C address input for module addressing.
D7	Digital GND	In	Supply	Digital Ground
D8	Digital GND	In	Supply	Digital Ground
D9	I2CAD2	In	LVTTTL	I <sup>2</sup> C address input for module addressing (MSB).



Table 39. Input and Output Termination Description (Sheet 4 of 9)

Pin Number	Symbol	I/O	Logic	Description
D10	Digital GND	In	Supply	Digital Ground
D11	Digital GND	In	Supply	Digital Ground
D12	NIC	N/A	N/A	No Internal Connection
D13	Digital GND	In	Supply	Digital Ground
D14	Digital GND	In	Supply	Digital Ground
D15	NIC	N/A	N/A	No Internal Connection
D16	Digital GND	In	Supply	Digital Ground
D17	Digital GND	In	Supply	Digital Ground
D18	LsPOWMON	Out	Analog	Laser power monitor. Output proportional to transmit laser average output power. Nominal value of 0.5 V should remain constant due to high gain power control loop. Range: 0–2 V, ± 100 µA
D19	Digital GND	In	Supply	Digital Ground
D20	Digital GND	In	Supply	Digital Ground
D21	LsTEMPMON	Out	Analog	Laser temperature monitor. Output proportional to transmit laser temperature $V = 0.764 * e^{3887 * (1/T - 1/298)}$ Volts, where T is temp in Kelvins. Nominally 0.4 to 0.6 V under normal operation. Range: 0–3.3 V, ± 100 µA
D22	Digital GND	In	Supply	Digital Ground
D23	Digital GND	In	Supply	Digital Ground
D24	NIC	N/A	N/A	No Internal Connection
D25	Digital GND	In	Supply	Digital Ground
D26	Digital GND	In	Supply	Digital Ground
D27	NIC	N/A	N/A	No Internal Connection
D28	Digital GND	In	Supply	Digital Ground
D29	Digital GND	In	Supply	Digital Ground
D30	LsPOWALM	Out	LVTTTL Logic 0: Alarm Logic 1: Normal	Laser power alarm. Logic high when the laser output power drops to half of the beginning of life output power, and corresponds to a voltage of 0.25 V on the Laser Power Monitor (LsPOWMON) analog voltage.
E1	RxDout8P	Out	LVDS	Receiver ( $1/16$ line bit rate) data output, differential pairs.
E2	RxDout8N	Out	LVDS	Receiver ( $1/16$ line bit rate) data output, differential pairs.
E3	Digital GND	In	Supply	Digital Ground
E4	RxDout9P	Out	LVDS	Receiver ( $1/16$ line bit rate) data output, differential pairs.
E5	RxDout9N	Out	LVDS	Receiver ( $1/16$ line bit rate) data output, differential pairs.
E6	Digital GND	In	Supply	Digital Ground
E7	RxDout10P	Out	LVDS	Receiver ( $1/16$ line bit rate) data output, differential pairs.
E8	RxDout10N	Out	LVDS	Receiver ( $1/16$ line bit rate) data output, differential pairs.
E9	Digital GND	In	Supply	Digital Ground
E10	RxDout11P	Out	LVDS	Receiver ( $1/16$ line bit rate) data output, differential pairs.
E11	RxDout11N	Out	LVDS	Receiver ( $1/16$ line bit rate) data output, differential pairs.
E12	Digital GND	In	Supply	Digital Ground
E13	RxPOCLKP	Out	LVDS	Receiver ( $1/16$ line bit rate MHz) clock output, differential pairs, aligned with output data.



**Table 39. Input and Output Termination Description (Sheet 5 of 9)**

Pin Number	Symbol	I/O	Logic	Description
E14	RxPOCLKN	Out	LVDS	Receiver ( $1/16$ line bit rate MHz) clock output, differential pairs, aligned with output data.
E15	Digital GND	In	Supply	Digital Ground
E16	TxDin8P	In	LVDS, internally 100 $\Omega$ terminated	Transmitter ( $1/16$ line bit rate) data input, differential pairs.
E17	TxDin8N	In	LVDS, internally 100 $\Omega$ terminated	Transmitter ( $1/16$ line bit rate) data input, differential pairs.
E18	Digital GND	In	Supply	Digital Ground
E19	TxDin9P	In	LVDS, internally 100 $\Omega$ terminated	Transmitter ( $1/16$ line bit rate) data input, differential pairs.
E20	TxDin9N	In	LVDS, internally 100 $\Omega$ terminated	Transmitter ( $1/16$ line bit rate) data input, differential pairs.
E21	Digital GND	In	Supply	Digital Ground
E22	TxDin10P	In	LVDS, internally 100 $\Omega$ terminated	Transmitter ( $1/16$ line bit rate) data input, differential pairs.
E23	TxDin10N	In	LVDS, internally 100 $\Omega$ terminated	Transmitter ( $1/16$ line bit rate) data input, differential pairs.
E24	Digital GND	In	Supply	Digital Ground
E25	TxDin11P	In	LVDS, internally 100 $\Omega$ terminated	Transmitter ( $1/16$ line bit rate) data input, differential pairs.
E26	TxDin11N	In	LVDS, internally 100 $\Omega$ terminated	Transmitter ( $1/16$ line bit rate) data input, differential pairs.
E27	Digital GND	In	Supply	Digital Ground
E28	TxPCLKP	Out	LVDS	Transmitter ( $1/16$ line bit rate) reference clock output, differential pair
E29	TxPCLKN	Out	LVDS	Transmitter ( $1/16$ line bit rate) reference clock output, differential pair
E30	Digital GND	In	Supply	Digital Ground
F1	NIC	N/A	N/A	No Internal Connection
F2	NIC	N/A	N/A	No Internal Connection
F3	RxPOWMON	Out	Analog	Output voltage proportional to average received optical power. Referenced to 0 V with typ. slope of 1 V/mW (min. 0.8 V/mW, max. 1.26 V/mW)
F4	+3.3 V Digital	In	Supply	Digital Power
F5	+3.3 V Digital	In	Supply	Digital Power
F6	RxPOWALM	Out	LVTTTL Logic 0: No input signal Logic 1: Input signal present	Receiver loss of average power alarm. Logic high for signal above receiver sensitivity. Low for signal $\leq$ 30 dBm.
F7	+3.3 V Digital	In	Supply	Digital Power
F8	+3.3 V Digital	In	Supply	Digital Power
F9	NIC	N/A	N/A	No Internal Connection
F10	-5.2 V Digital	In	Supply	Digital Power
F11	-5.2 V Digital	In	Supply	Digital Power
F12	NIC	N/A	N/A	No Internal Connection
F13	-5.2 V Digital	In	Supply	Digital Power
F14	-5.2 V Digital	In	Supply	Digital Power



Table 39. Input and Output Termination Description (Sheet 6 of 9)

Pin Number	Symbol	I/O	Logic	Description
F15	RxREFSEL	In	LVTTTL Logic 0: $1/64$ line bit rate Logic 1: $1/16$ line bit rate	Selects RxREFCLK—either $1/64$ or $1/16$ line bit rate MHz.
F16	NIC	N/A	N/A	No Internal Connection
F17	NIC	N/A	N/A	No Internal Connection
F18	LsBIASMON	Out	Analog	Laser bias monitor. Output proportional to transmit laser DC bias $V = 20 * (1 - \text{Offset}) \text{ mV}$ where $I = \text{laser bias mA}$ . Range: 0–2 V, $\pm 100 \mu\text{A}$
F19	+3.3 V Digital	In	Supply	Digital Power
F20	+3.3 V Digital	In	Supply	Digital Power
F21	LsENABLE	In	LVTTTL Logic 0: Enabled Logic 1: Disabled	Function: Transmitter laser enable input.
F22	+3.3 V Digital	In	Supply	Digital Power
F23	+3.3 V Digital	In	Supply	Digital Power
F24	LsBIASALM	Out	LVTTTL Logic 0: Alarm Logic 1: Normal	Laser bias alarm. Alarm if laser bias > 80 mA for 1310 nm applications and > 100 mA for 1550 nm applications.
F25	-5.2 V Digital	In	Supply	Digital Power
F26	-5.2 V Digital	In	Supply	Digital Power
F27	LsTEMPALM	Out	LVTTTL Logic 0: Alarm Logic 1: Normal	Laser temperature alarm. Alarm if laser temperature more than 5 degrees from initial set point.
F28	-5.2 V Digital	In	Supply	Digital Power
F29	-5.2 V Digital	In	Supply	Digital Power
F30	TxREFSEL	In	LVTTTL Logic 0: $1/64$ line bit rate MHz Logic 1: $1/16$ line bit rate MHz	Selects TxREFSEL—either $1/64$ or $1/16$ line bit rate MHz.
G1	RxDout12P	Out	LVDS	Receiver ( $1/16$ line bit rate) data output, differential pairs.
G2	RxDout12N	Out	LVDS	Receiver ( $1/16$ line bit rate) data output, differential pairs.
G3	Digital GND	In	Supply	Digital Ground
G4	RxDout13P	Out	LVDS	Receiver ( $1/16$ line bit rate) data output, differential pairs.
G5	RxDout13N	Out	LVDS	Receiver ( $1/16$ line bit rate) data output, differential pairs.
G6	Digital GND	In	Supply	Digital Ground
G7	RxDout14P	Out	LVDS	Receiver ( $1/16$ line bit rate) data output, differential pairs.
G8	RxDout14N	Out	LVDS	Receiver ( $1/16$ line bit rate) data output, differential pairs.
G9	Digital GND	In	Supply	Digital Ground
G10	RxDout15P	Out	LVDS	Receiver ( $1/16$ line bit rate) data output, differential pairs.
G11	RxDout15N	Out	LVDS	Receiver ( $1/16$ line bit rate) data output, differential pairs.
G12	Digital GND	In	Supply	Digital Ground
G13	NIC	N/A	N/A	No Internal Connection
G14	NIC	N/A	N/A	No Internal Connection

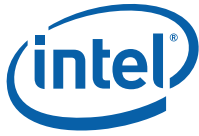

**Table 39. Input and Output Termination Description (Sheet 7 of 9)**

Pin Number	Symbol	I/O	Logic	Description
G15	Digital GND	In	Supply	Digital Ground
G16	TxDin12P	In	LVDS, internally 100 Ω terminated	Transmitter (1/16 line bit rate) data input, differential pairs.
G17	TxDin12N	In	LVDS, internally 100 Ω terminated	Transmitter (1/16 line bit rate) data input, differential pairs.
G18	Digital GND	In	Supply	Digital Ground
G19	TxDin13P	In	LVDS, internally 100 Ω terminated	Transmitter (1/16 line bit rate) data input, differential pairs.
G20	TxDin13N	In	LVDS, internally 100 Ω terminated	Transmitter (1/16 line bit rate) data input, differential pairs.
G21	Digital GND	In	Supply	Digital Ground
G22	TxDin14P	In	LVDS, internally 100 Ω terminated	Transmitter (1/16 line bit rate) data input, differential pairs.
G23	TxDin14N	In	LVDS, internally 100 Ω terminated	Transmitter (1/16 line bit rate) data input, differential pairs.
G24	Digital GND	In	Supply	Digital Ground
G25	TxDin15P	In	LVDS, internally 100 Ω terminated	Transmitter (1/16 line bit rate) data input, differential pairs.
G26	TxDin15N	In	LVDS, internally 100 Ω terminated	Transmitter (1/16 line bit rate) data input, differential pairs.
G27	Digital GND	In	Supply	Digital Ground
G28	TxPICLKP	In	LVDS, internally 100 Ω terminated	Transmitter (1/16 line bit rate) input clock, differential pair, aligned with input data.
G29	TxPICLKN	In	LVDS, internally 100 Ω terminated	Transmitter (1/16 line bit rate) input clock, differential pair, aligned with input data.
G30	Digital GND	In	Supply	Digital Ground
H1	Frame GND	In	Supply	Frame Ground
H2	Frame GND	In	Supply	Frame Ground
H3	NIC	N/A	N/A	No Internal Connection
H4	Frame GND	In	Supply	Frame Ground
H5	Frame GND	In	Supply	Frame Ground
H6	NIC	N/A	N/A	No Internal Connection
H7	Analog GND	In	Supply	Analog Ground
H8	Analog GND	In	Supply	Analog Ground
H9	NIC	N/A	N/A	No Internal Connection
H10	Analog GND	In	Supply	Analog Ground
H11	Analog GND	In	Supply	Analog Ground
H12	NIC	N/A	N/A	No Internal Connection
H13	Analog GND	In	Supply	Analog Ground
H14	Analog GND	In	Supply	Analog Ground
H15	AlmInterrupt	Out	open drain/collector	Electrical "OR" of all receive and transmit alarms.
H16	Analog GND	In	Supply	Analog Ground
H17	Analog GND	In	Supply	Analog Ground
H18	NIC	N/A	N/A	No Internal Connection

**Table 39. Input and Output Termination Description (Sheet 8 of 9)**

Pin Number	Symbol	I/O	Logic	Description
H19	Analog GND	In	Supply	Analog Ground
H20	Analog GND	In	Supply	Analog Ground
H21	NIC	N/A	N/A	No Internal Connection
H22	Analog GND	In	Supply	Analog Ground
H23	Analog GND	In	Supply	Analog Ground
H24	NIC	N/A	N/A	No Internal Connection
H25	Frame GND	In	Supply	Frame Ground
H26	Frame GND	In	Supply	Frame Ground
H27	NIC	N/A	N/A	No Internal Connection
H28	Frame GND	In	Supply	Frame Ground
H29	Frame GND	In	Supply	Frame Ground
H30	TxLINETIMSEL	In	LVTTL Logic 0: Line Timing Logic 1: TxREFCLK Timing	Line timing mode internally loops recovered receive clock (RxPOCLK) back to TxREFCLK.
J1	NIC	N/A	N/A	No Internal Connection
J2	NIC	N/A	N/A	No Internal Connection
J3	NIC	N/A	N/A	No Internal Connection
J4	NIC	N/A	N/A	No Internal Connection
J5	NIC	N/A	N/A	No Internal Connection
J6	NIC	N/A	N/A	No Internal Connection
J7	NIC	N/A	N/A	No Internal Connection
J8	NIC	N/A	N/A	No Internal Connection
J9	NIC	N/A	N/A	No Internal Connection
J10	NIC	N/A	N/A	No Internal Connection
J11	NIC	N/A	N/A	No Internal Connection
J12	NIC	N/A	N/A	No Internal Connection
J13	NIC	N/A	N/A	No Internal Connection
J14	RxALM INT	Out	open drain/collector	Electrical "OR" of all receive alarms.
J15	NIC	N/A	N/A	No Internal Connection
J16	TxALM INT	Out	open drain/collector	Electrical "OR" of all transmit alarms.
J17	NIC	N/A	N/A	No Internal Connection
J18	NIC	N/A	N/A	No Internal Connection
J19	NIC	N/A	N/A	No Internal Connection
J20	NIC	N/A	N/A	No Internal Connection
J21	TxRateSel1	In	LVTTL	Transmit rate select. See <a href="#">Table 34</a> .
J22	NIC	N/A	N/A	No Internal Connection
J23	NIC	N/A	N/A	No Internal Connection
J24	NIC	N/A	N/A	No Internal Connection
J25	NIC	N/A	N/A	No Internal Connection



**Table 39. Input and Output Termination Description (Sheet 9 of 9)**

Pin Number	Symbol	I/O	Logic	Description
J26	NIC	N/A	N/A	No Internal Connection
J27	NIC	N/A	N/A	No Internal Connection
J28	NIC	N/A	N/A	No Internal Connection
J29	TxTrace	In	Analog	No Internal Connection
J30	NIC	N/A	N/A	No Internal Connection
K1	NIC	N/A	N/A	No Internal Connection
K2	NIC	N/A	N/A	No Internal Connection
K3	NIC	N/A	N/A	No Internal Connection
K4	+3.3 V Analog	In	Supply	Analog Power
K5	+3.3 V Analog	In	Supply	Analog Power
K6	NIC	N/A	N/A	No Internal Connection
K7	NIC	N/A	N/A	No Internal Connection
K8	NIC	N/A	N/A	No Internal Connection
K9	RxMutePOCLK	In	LVTTTL	Mutes the RxPOCLK.
K10	-5.2 V Analog	In	Supply	Analog Power
K11	-5.2 V Analog	In	Supply	Analog Power
K12	RxMuteMclk	In	LVTTTL	Mutes the RxMCLK.
K13	-5.2 V Analog	In	Supply	Analog Power
K14	-5.2 V Analog	In	Supply	Analog Power
K15	I2CCLOCK	In/ Out	open drain/collector	I <sup>2</sup> C Clock Input for remote access.
K16	NIC	N/A	N/A	No Internal Connection
K17	NIC	N/A	N/A	No Internal Connection
K18	I2CDATA	In/ Out	open drain/collector	I <sup>2</sup> C Data input/output for remote access—see application note EEP13220APP for details regarding the contents of the EEPROM.
K19	+3.3 V Analog	In	Supply	Analog Power
K20	+3.3 V Analog	In	Supply	Analog Power
K21	TxRateSel0	In	LVTTTL	Transmit rate select. See Table 34.
K22	+3.3 V Analog	In	Supply	Analog Power
K23	+3.3 V Analog	In	Supply	Analog Power
K24	TxRESET	In	LVTTTL	Transmitter asynchronous system reset
K25	-5.2 V Analog	In	Supply	Analog Power
K26	-5.2 V Analog	In	Supply	Analog Power
K27	TxFIFORES	In	LVTTTL	Mux FIFO reset
K28	-5.2 V Analog	In	Supply	Analog Power
K29	-5.2 V Analog	In	Supply	Analog Power
K30	TxFIFOERR	Out	LVTTTL	Mux FIFO error indicator.



### 3.7 Integrated Power Supply Sequencing

No power supply sequencing is required for this transceiver.

### 3.8 Mechanical Layout and Configuration

Figure 4 through Figure 7 show the TXN13220/1/4/5/7/8 Transceiver integrated heatsink options.

A flat top version (which has no integral heat fins) also is offered for use with customer-supplied conductive cooling.

*Note:* Reference environment: 1" board-to-board spacing, single isolated transponder.

**Figure 4. Heatsink "A" – 3" x 2.2" x 0.53"**

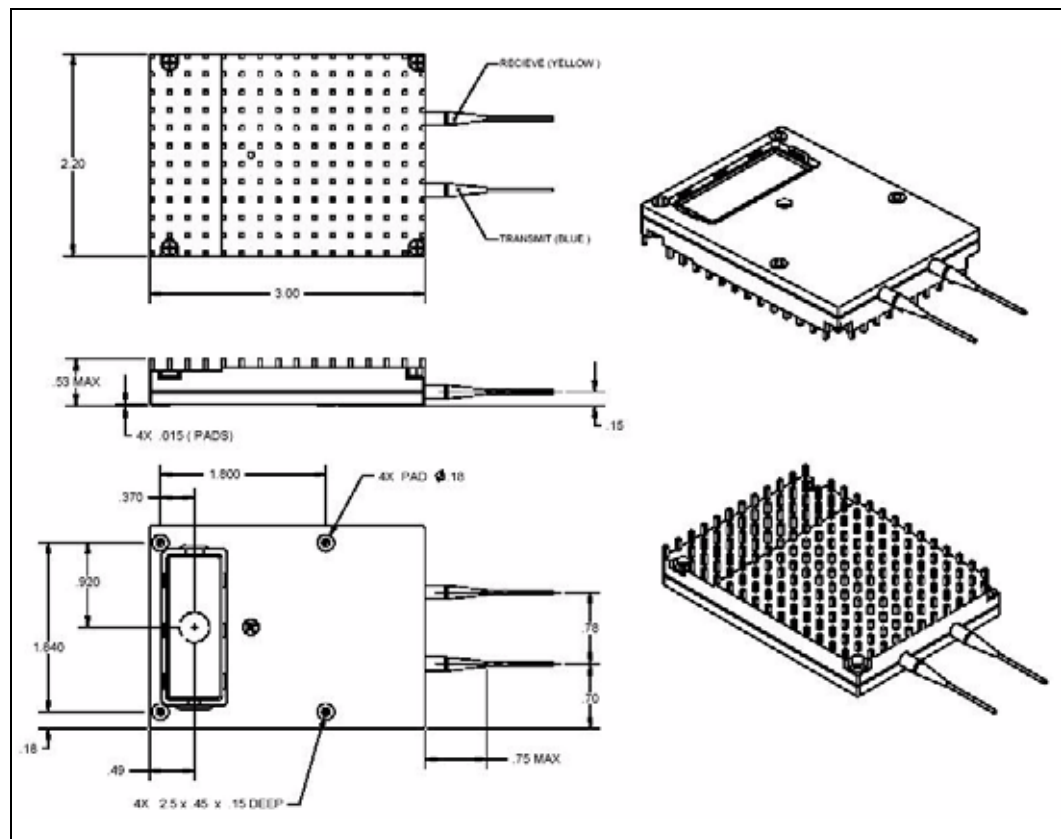
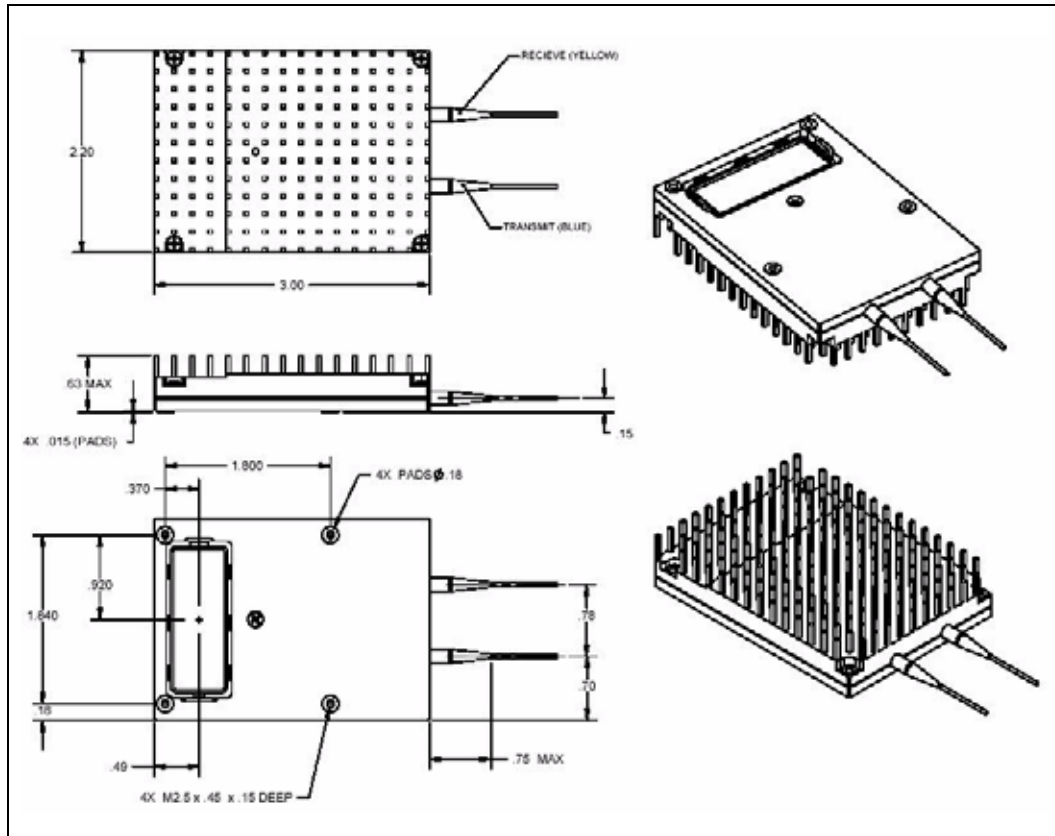

Figure 5. Heatsink "B" – 3" x 2.2" x 0.63"



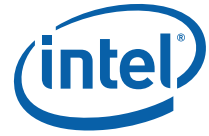

Figure 6. Heatsink "C" – 3" x 2.2" x 0.7"

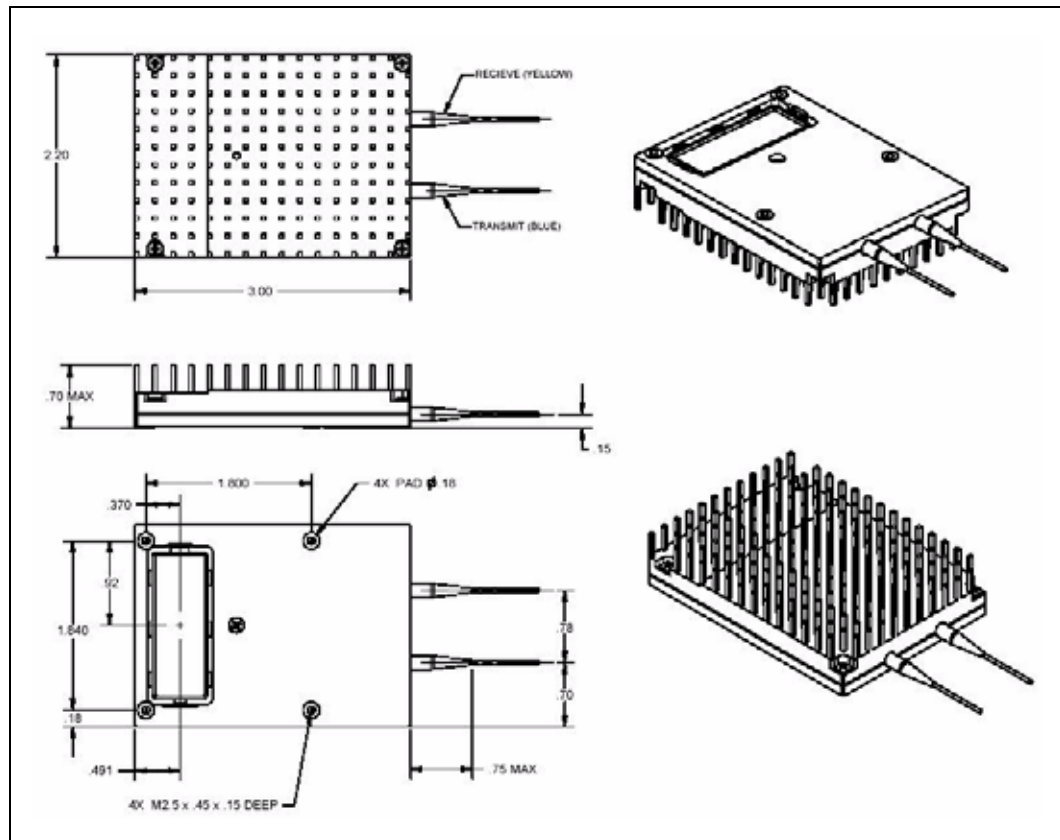
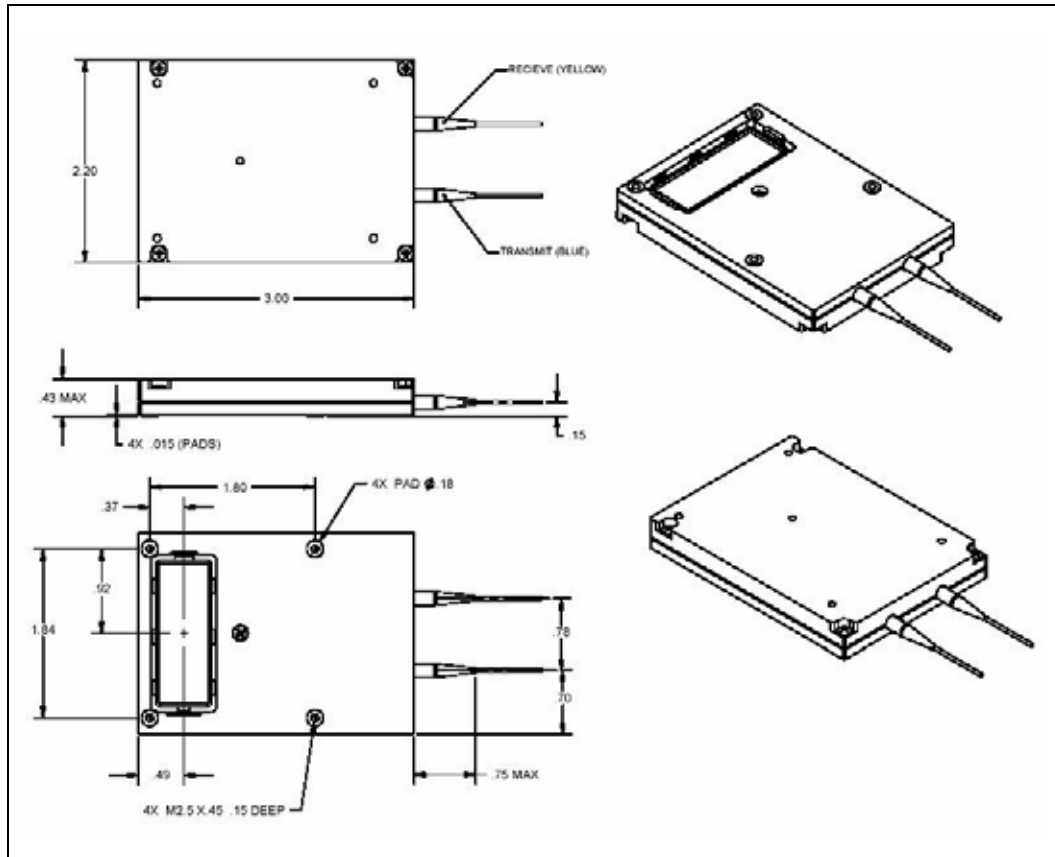

Figure 7. Heatsink "D" – 3" x 2.2" x 0.53" Flat Top





## 4.0 Regulatory Compliance

This section discusses the following topics:

- Section 4.1, “Electromagnetic Compatibility Compliance” on page 47
- Section 4.2, “Safety Compliance” on page 48
- Section 4.3, “Compliance with Restriction of Hazardous Substances” on page 48
- Section 4.4, “Product Certification Markings and Compliance Statements” on page 49

### 4.1 Electromagnetic Compatibility Compliance

Table 40 lists emissions and immunity regulations with which the TXN13220/1/4/5/7/8 Transceivers comply when tested in a representative chassis.

**Table 40. Electromagnetic Compatibility Compliance**

Regulatory Requirement	Applicable Standards	Performance
Electromagnetic Interference (EMI)	<ul style="list-style-type: none"> <li>• FCC rules, Part 15, Subpart B</li> <li>• EN 55022</li> </ul>	Meets Class B limits with a minimum 6 dB margin
Electrostatic Discharge (ESD)	JEDEC JESD22-A114-B Human Body Model	± 2 kV contact discharge to connector electrical pins with no degradation in performance or loss of function
	EN 61000-4-2	<ul style="list-style-type: none"> <li>• ±8 kV air discharge</li> <li>• ±4 kV contact discharge to face plate</li> </ul> Meets Level B test criteria (that is, no degradation of performance or loss of function occurs).  <b>NOTE:</b> Actual ESD may vary depending on system configuration.
Radio Frequency Electro-Magnetic field (Radiated immunity)	EN 61000-4-3, Level A test criteria	10 V/m from 80 MHz to 1 GHz with no degradation of performance or loss of function



## 4.2 Safety Compliance

Table 41 lists and describes the relevant safety regulations with which the TXN13220/1/4/5/7/8 Transceivers comply.

Table 41. Safety Compliance

Requirement	Regulation	Title
Product Safety	UL 60950-1:2003 / CSA C22.2 No. 60950-1-03	Information Technology Equipment – Safety - Part 1: General Requirements (USA and Canada)
	EN 60950-1:2001 + A11	Information Technology Equipment – Safety - Part 1: General Requirements (European Union)
	IEC 60950-1:2001	Information Technology Equipment – Safety - Part 1: General Requirements (International)
	GR-63-CORE Section 4.2, Clause 4.2.3.1	Compliant with the fire resistance requirements of Telcordia Technologies Generic Requirements GR-63-CORE document for discrete electronic components.
Laser Safety	21CFR1040.10	Title 21 Chapter I Subchapter J – Radiological Health Part 1040: Performance Standards for Light-Emitting Products
	EN 60825-1: 1994 +A1 +A2	Safety of Laser Products - Part 1: Equipment Classification, Requirements and User's Guide
	IEC 60825-1: 1993 +A1 +A2	Safety of Laser Products - Part 1: Equipment Classification, Requirements and User's Guide
	EN 60825-2: 2000	Safety of Laser Products - Part 2: Safety of Optical Fiber Communication Systems
	IEC 60825-2: 2000	Safety of Laser Products - Part 2: Safety of Optical Fiber Communication Systems

## 4.3 Compliance with Restriction of Hazardous Substances

This product complies with the European Union directive for Restriction of Hazardous Substances (RoHS) – Restriction on the Use of Certain Hazardous Substances in Electrical and Electronic Equipment, Directive 2002/95/EC plus amendments.

This product does contain lead (a RoHS-restricted substance) in solder but utilizes the application exemption below for servers, networking, and telecommunications. For applications other than those covered by the exemption below, the product is not confirmed as RoHS compliant.

- Lead in solders for servers, storage and storage array systems, network infrastructure equipment for switching, signaling, transmission as well as network management for telecommunications.

Also, certain discrete components do contain lead in amounts that exceed threshold concentration levels. This product uses the following applicable RoHS technology exemptions:



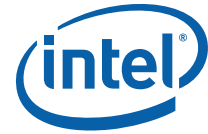

- Lead in optical and filter glass
- Lead in glass of electronic components
- Lead in electronic ceramic parts



## 4.4 Product Certification Markings and Compliance Statements

Table 42 lists the TXN13220/1/4/5/7/8 Transceiver product certification markings and compliance statements.

**Table 42. Product Certification Markings and Compliance Statements**

Origin and Description	Markings and Compliance Statements
<b>Markings</b>	
CE mark. The CE (Conformité Européene*) mark indicates compliance to the European Union Low Voltage directive (73/23/EEC).	
TÜV Rheinland type approval mark for components and subassemblies for the European Union. The Technischer Überwachungsverein* (TÜV - German for "Technical Inspection Association") Rheinland type approval mark is for components and subassemblies for the European Union. Where space does not permit, the smaller alternate TÜV mark (see the next row in this table) may be used.	
TÜV Rheinland type approval mark for components and subassemblies for the European Union - <i>Alternate</i> . This alternate mark may be used where space constraints exist that do not permit use of the TÜV Rheinland mark in the previous row of this table.	Alternate TÜV mark: 
UL Recognized Component mark for the USA and Canada.	
<b>Compliance Statements</b>	
USA Food and Drug Administration (FDA), Center for Devices and Radiological Health compliance statement.	Complies with 21CFR 1040.10 and 1040.11 except for deviations pursuant to Laser Notice No. 50, dated July 26, 2001.
USA FDA, Center for Devices and Radiological Health compliance statement - <i>Alternate</i> . Use the alternate statement listed, as needed.	Alternate FDA compliance statement: Complies with FDA performance standards for laser products except for deviations pursuant to Laser Notice No. 50, dated July 26, 2001.



## 5.0 Ordering Information

The TXN13220/1/4/5/7/8 Transceiver is available with several optical connector options. Specify the complete part number by choosing the transponder and connector number from the available options shown in Figure 8. Unless otherwise specified, all transceivers measure 3 inches long by 2.2 inches wide.

For example: "TXN132201013B01" Description: 9.95 Gbps SONET transceiver, 7 km reach, 1310 nm, 0.63" tall heatsink, with jitter filter, with SC-UPC connectors (color coded receive yellow, transmit blue).

Figure 8. Ordering Information

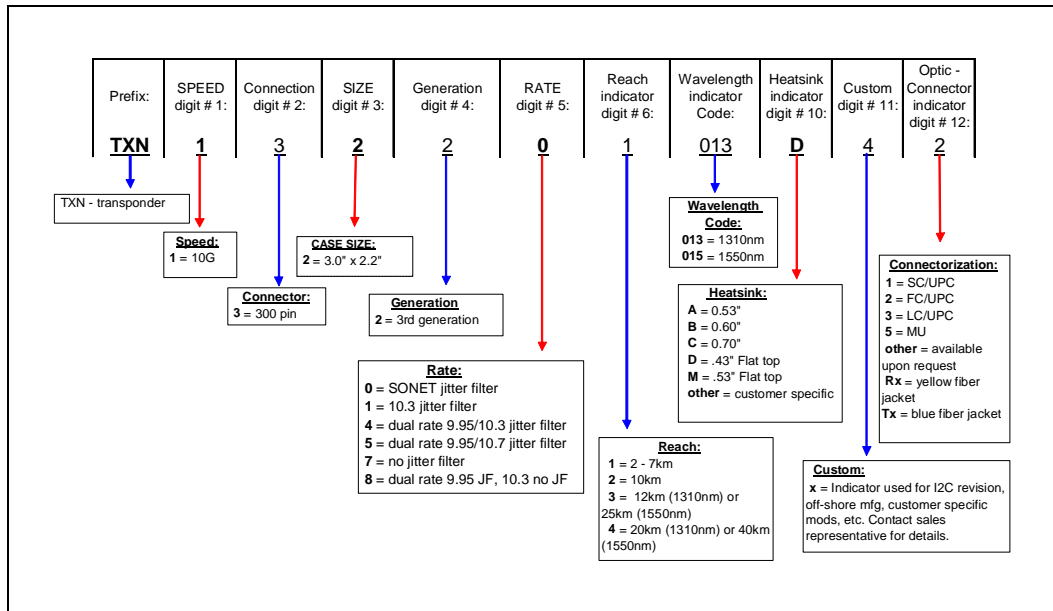



## 6.0 Acronyms

Table 43 lists acronyms for this document.

**Table 43. Acronyms (Sheet 1 of 2)**

Acronym	Meaning
10GBASE-ER	10 Mbit/s Baseband Extended Reach
10GBASE-EW	10 Mbit/s Baseband Extended Reach WAN (Wide-Area Network)
10GBASE-LR	10 Mbit/s Baseband Long Reach
10GBASE-LW	10 Mbit/s Baseband Long-Reach WAN (Wide-Area Network)
CDR	Clock and Data Recovery
CFR	Code of Federal Regulations
DFB	Distributed Feedback (type of laser)
EEPROM	Electrically Erasable Programmable Read Only Memory
EML	Electroabsorption Modulated Laser
FC	Fibre Channel
FCC	Federal Communications Commission
FEC	Forward Error Correction
FIFO	First-In, First-Out
GbE	Gigabit Ethernet
I <sup>2</sup> C	Inter-Integrated Circuit
IEEE	Institute of Electrical and Electronics Engineers
ITU	International Telecommunication Union
LVDS	Low-Voltage Differential Signaling
LVPECL	Low-Voltage Pseudo Emitter-Coupled Logic
LVTTL	Low-Voltage Transistor-Transistor Logic
MSA	Multisource Agreement
OC	Optical Carrier
OIF	Optical Internetworking Forum
OMA	Optical Modulation Amplitude
PIN	Positive Intrinsic Negative
PLL	Phase-Locked Loop
PRBS	Pseudo-Random Bit Sequence
RIN	Relative Intensity Noise
RoHS	Restriction of Hazardous Substances
SC	Self-Clearing
SDH	Synchronous Digital Hierarchy
SerDes	Serializer/Deserializer
SONET	Synchronous Optical NETWORK
SR	Short Reach
STM	Synchronous Transport Mode



**Table 43. Acronyms (Sheet 2 of 2)**

Acronym	Meaning
TDP	Transmitter and Dispersion Penalty
UPC	Ultra-Physical Contact
VCO	Voltage-Controlled Oscillator

§ §